

Parts Catalog

Mazda MX-5 MIATA U.S.A. '94

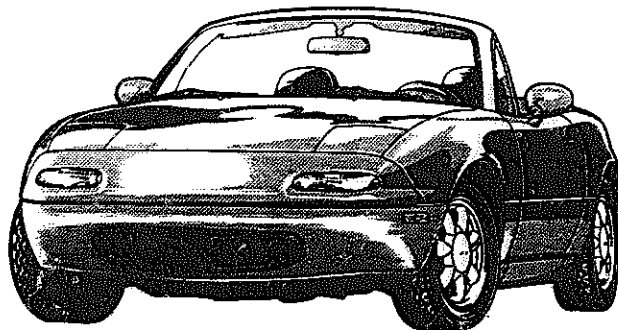

NA3***-500001-8C0000

Apr. '95 (FINAL)
Catalog No. AU-NA04-03

mazda
© 1995 Mazda Motor Corporation

LAYOUT OF CONTENTS / DISPOSITION TYPOGRAPHIQUE DE CONTENU / DISPOSICION DEL CONTENIDO / ANORDNUNG DES INHALTS



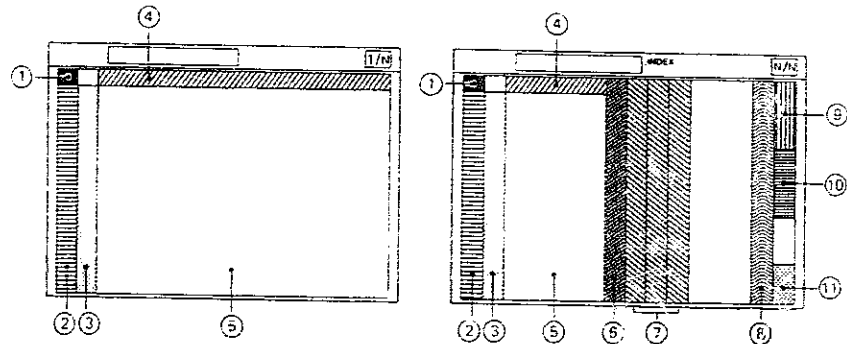





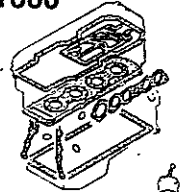
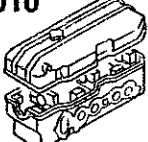
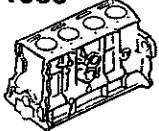
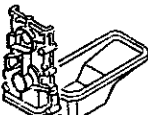

- The following is a typical example of the layout of contents on Mazda microfiche part catalog
- Voici un exemple typique de la disposition typographique de contenu dans les microfiches de catalogue des pièces de Mazda.
- El siguiente es un ejemplo típico de la disposición del contenido en una microficha del catálogo de repuestos de Mazda.
- Folgendes ist ein typisches Beispiel der Inhaltsanordnung des Mazda-Mikrofiche-Teilekatalogs.

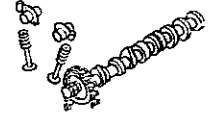

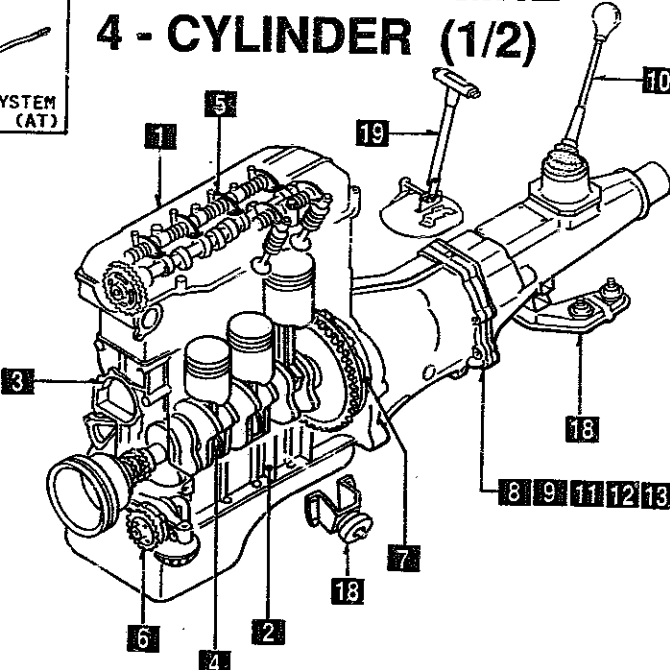
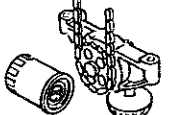
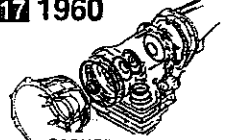
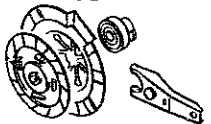
Remark : The items listed under ④ have been deleted from each fiche since Dec. '93

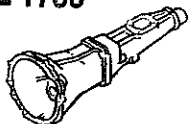
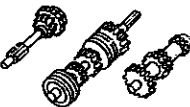
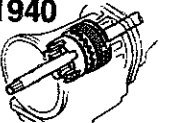
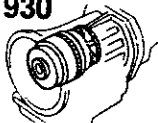
- | | | |
|--|---|---|
| ① • Layout of contents
• Disposition Typographique de Contenu
• Disposición del contenido
• Anordnung des Inhalts | ② • Pictorial Index
• Index par Schémas
• Índice Gráfico
• Illustrierter Index | ③ • Master Section No. Index
• Index des Numéros des Sections Totales
• Índice del Número de la Sección Maestra
• Hauptabschnittsnummer-Index |
| ④ • Section No. Index for the Column
• Index des Numéros des Sections pour les Colonnes
• N° de la Sección para el Índice
• Abschnittsnummer-Index für die Spalte | ⑤ • Illustration & Text
• Illustrations et Textes
• Ilustración y Texto
• Abbildung und Text | ⑥ • Part No. Index
• Index des Numéros des Pièces
• Índice de! N° de Pieza
• Teile-Nr.-Index |
| ⑦ • Alphabetical Index
• Index Alphabétique
• Índice Alfabético
• Alphabetischer Index | ⑧ • Model Identification
• Identification des Modèles
• Identificación del Modelo
• Modell-Kennzeichnung | ⑨ • Vehicle Identification System
• Système d'Identification de Véhicule
• Sistema de Identificación de Vehículo
• Fahrzeug-Identifikations-system |

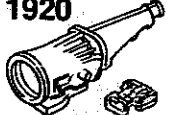

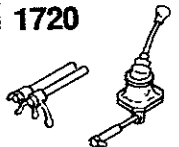



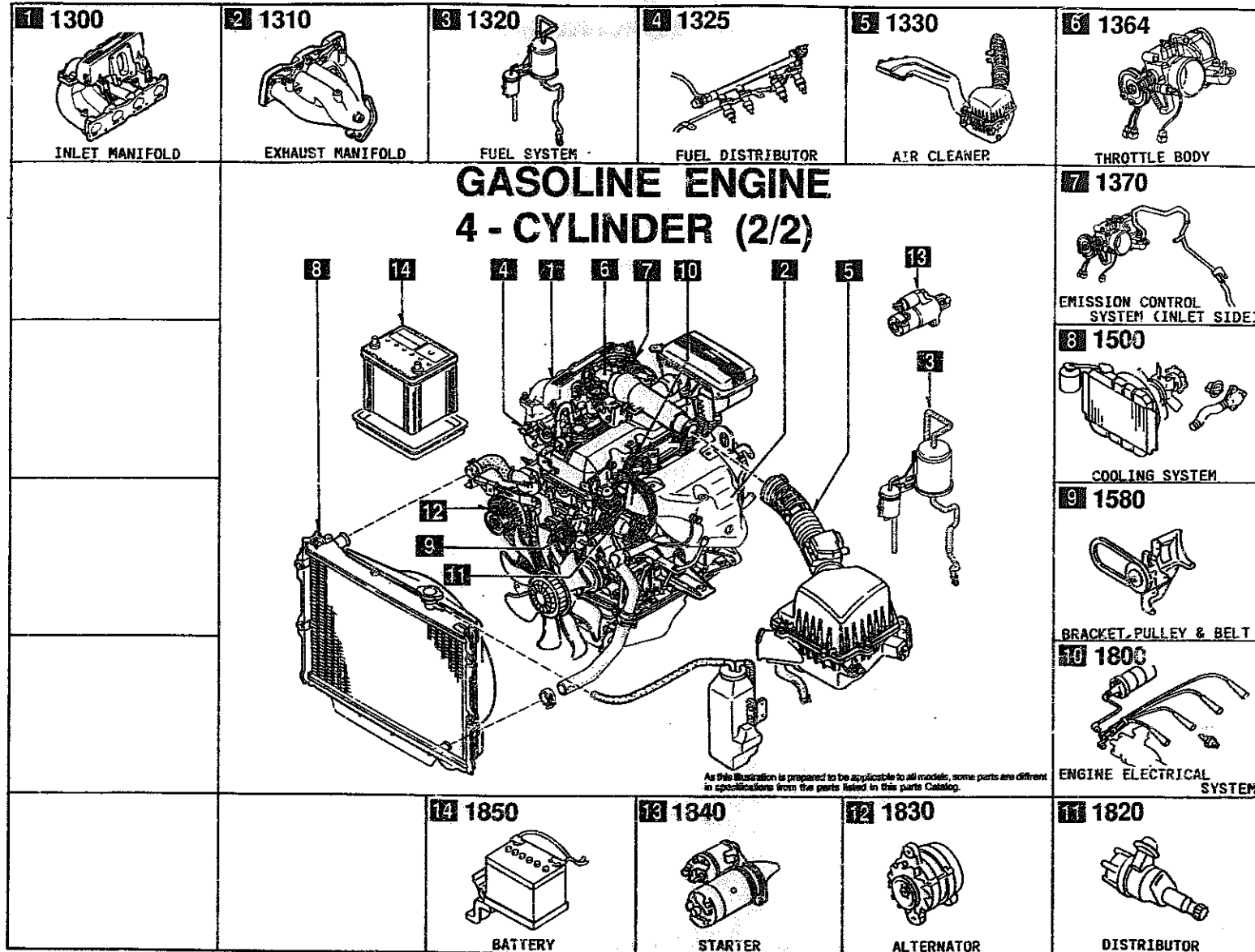



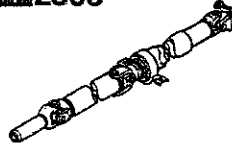
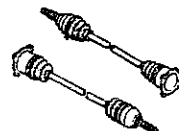

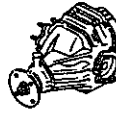
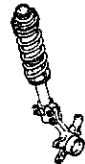
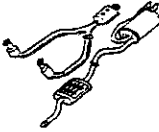
PICTORIAL INDEX

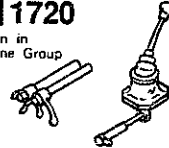
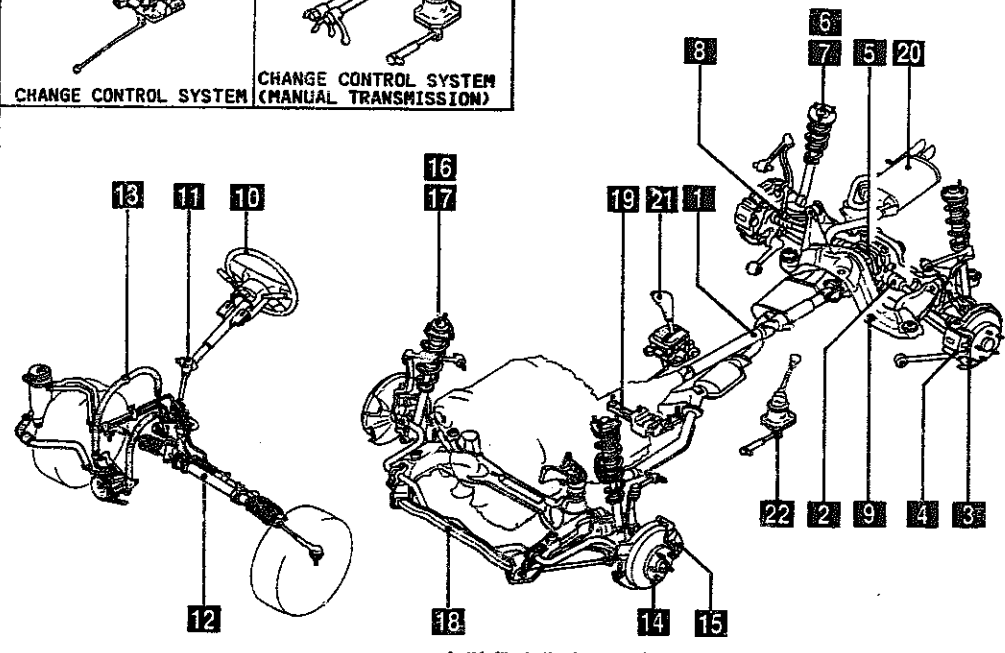
<p>1000</p>  <p>1010</p>  <p>CYLINDER HEAD & COVER</p>	<p>1030</p>  <p>CYLINDER BLOCK</p>	<p>1040</p>  <p>OIL PAN & TIMING COVER</p>	<p>1100</p>  <p>PISTON, CRANKSHAFT & FLYWHEEL</p>	<p>1200</p>  <p>VALVE SYSTEM</p>
<p>13 3900</p>  <p>Given in Chassis Group</p> <p>ENGINE & T/MISSION MOUNTINGS</p>	<p>GASOLINE ENGINE 4 - CYLINDER (1/2)</p> 			<p>1400</p>  <p>OIL PUMP & FILTER</p>
<p>17 1960</p>  <p>GASKET & SEAL KIT (AUTOMATIC)</p>	<p><small>As this illustration is prepared to be applicable to all models, some parts are different in specifications from parts listed in this parts Catalog.</small></p>			<p>1600</p>  <p>CLUTCH DISC & COVER (MANUAL)</p>
<p>16 1950</p>  <p>MANUAL LINKAGE SYSTEM (AUTOMATIC)</p>	<p>1700</p>  <p>TRANSMISSION CASE (MANUAL)</p>			<p>1710</p>  <p>TRANSMISSION GEARS (MANUAL)</p>
<p>15 1940</p>  <p>GOVERNOR, LOW & REVERSE PISTON (AUTOMATIC)</p>	<p>14 1930</p>  <p>CLUTCHES & PLANETARY GEARS (AUTOMATIC)</p>	<p>13 1925</p>  <p>CONTROL VALVE (AUTOMATIC)</p>	<p>12 1920</p>  <p>TRANSMISSION CASE & MAIN CONTROL SYSTEM (AUTOMATIC)</p>	<p>11 1910</p>  <p>TORQUE CONVERTER, OIL PUMP & PIPINGS (AUTOMATIC)</p>
				<p>10 1720</p>  <p>CHANGE CONTROL SYSTEM (MANUAL)</p>

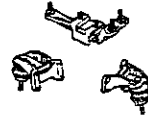

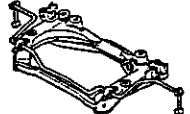
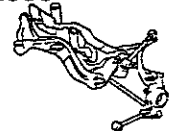
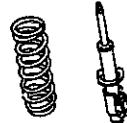

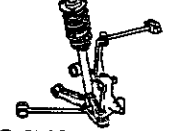

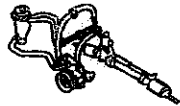

PICTORIAL INDEX

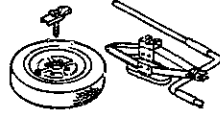

PICTORIAL INDEX

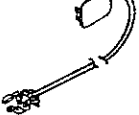
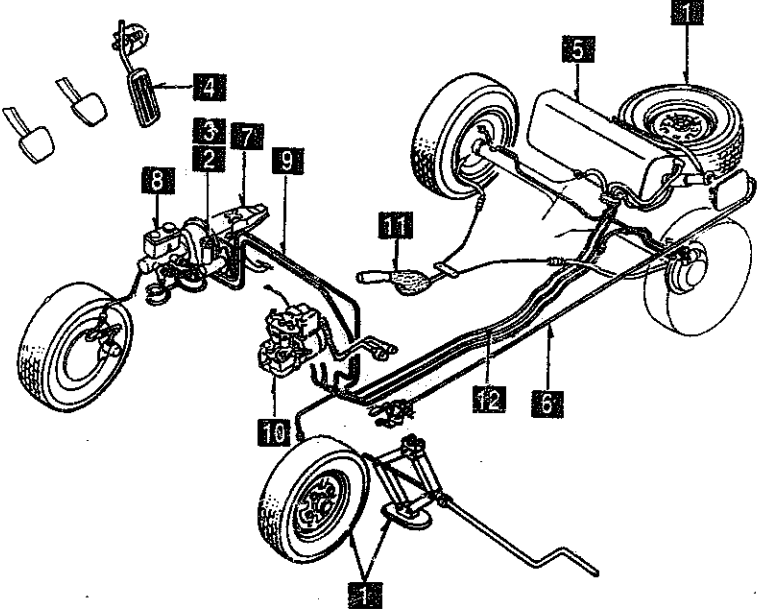
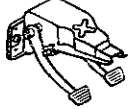
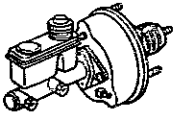

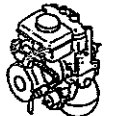
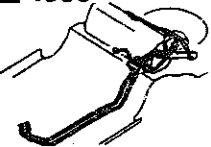





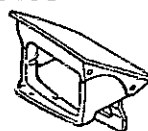
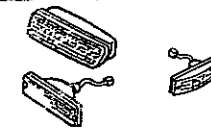
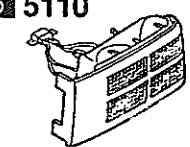

1 2505  REAR PROPELLER SHAFT	2 2550  REAR DRIVE SHAFT	3 2600  REAR AXLE	4 2610  REAR BRAKE MECHANISMS	5 2710  REAR DIFFERENTIALS	6 2800  REAR SUSPENSION MECHANISMS
20 4000  EXHAUST SYSTEM	21 4600  CHANGE CONTROL SYSTEM	22 1720 Given in Engine Group  CHANGE CONTROL SYSTEM (MANUAL TRANSMISSION)	<h2 style="text-align: center;">CHASSIS (1/2)</h2>  <p style="text-align: center; font-size: small;">As this illustration is prepared to be applicable to all models, some parts are different in specifications from parts listed in this parts Catalog.</p>		7 2801  REAR SPRING & DAMPER
19 3900  ENGINE & T/MISSION MOUNTINGS					8 2810  REAR STABILIZER
18 3410  CROSSMEMBER & STABILIZER					9 2830  REAR LOWER ARMS & SUB FRAME
17 3401  FRONT SPRING & DAMPER					10 3200  STEERING WHEEL
16 3400  FRONT SUSPENSION MECHANISMS	15 3310  FRONT BRAKE MECHANISMS	14 3300  FRONT AXLE			13 3240  POWER STEERING SYSTEM (FRONT)

PICTORIAL INDEX

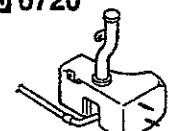
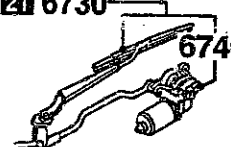
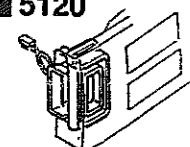

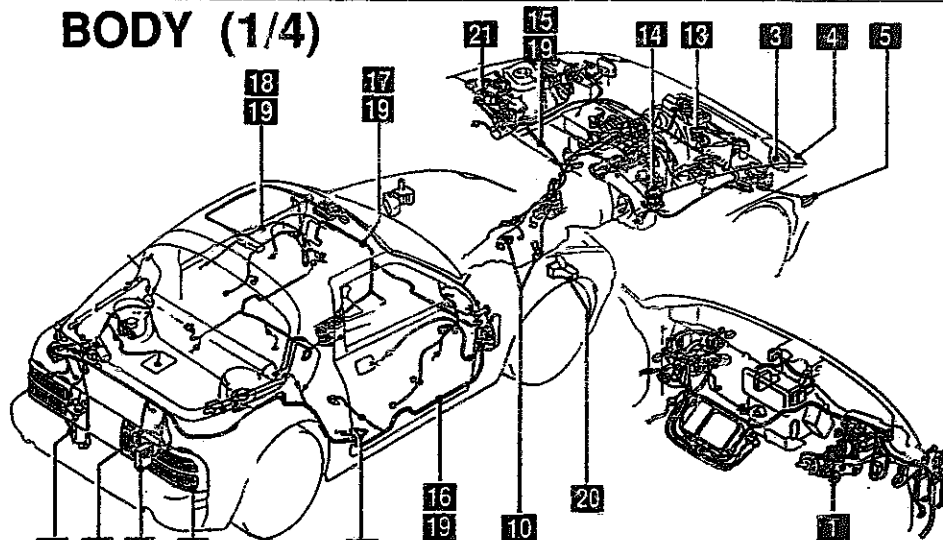
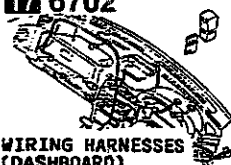

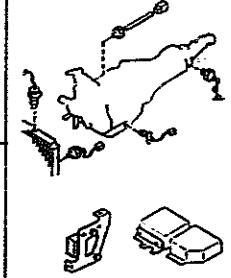

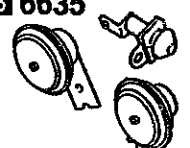
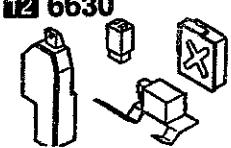



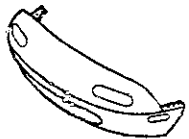

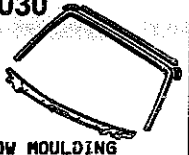
1 3700  TIRES & JACK	2 4140  CLUTCH RELEASE & MASTER CYLINDERS	3 4145  CLUTCH PIPINGS	4 4160  ACCELERATOR CONTROL SYSTEM	5 4200  FUEL TANK	6 4210  FUEL LID OPENER
<h3 style="margin: 0;">CHASSIS (2/2)</h3> 					
					7 4300  CLUTCH & BRAKE PEDALS
					8 4340  BRAKE MASTER CYLINDER & POWER BRAKE
					9 4360  BRAKE PIPINGS
					10 4370  ANTI-LOCK BRAKE SYSTEM
				12 4500  FUEL PIPINGS	11 4400  PARKING BRAKE SYSTEM

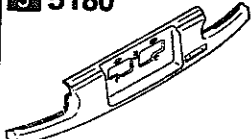
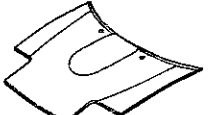
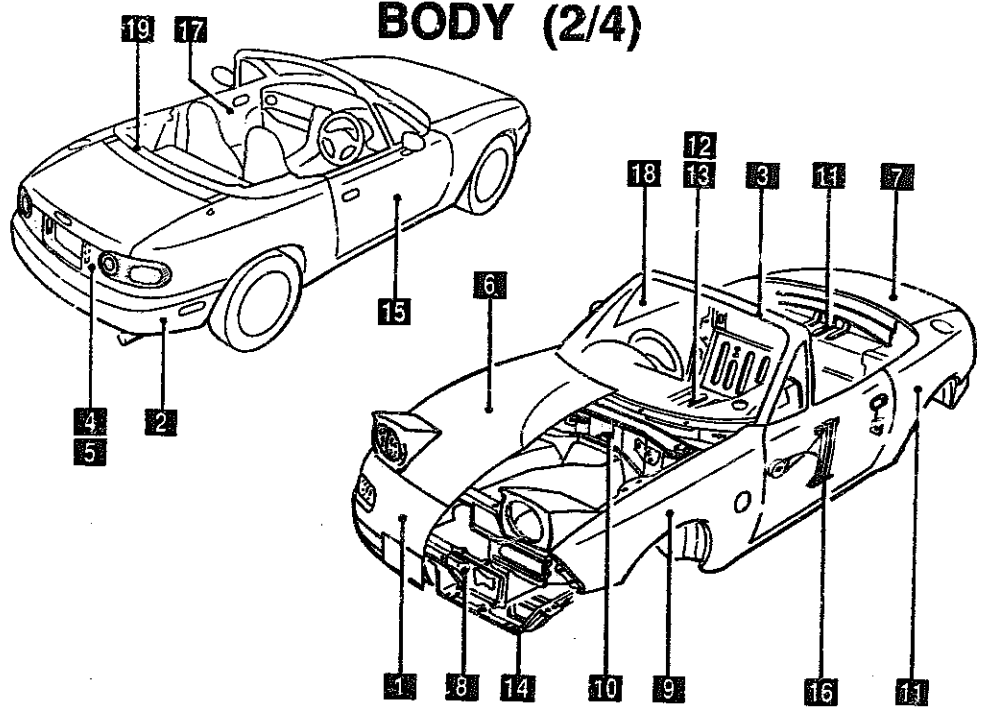
As this illustration is prepared to be applicable to all models, some parts are different in specifications from parts listed in this parts Catalog.



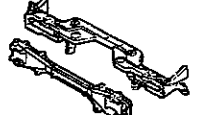
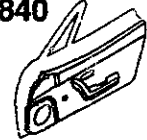

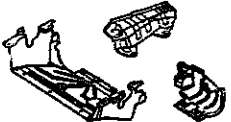
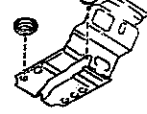
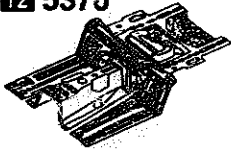
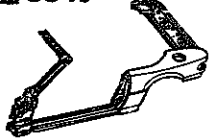
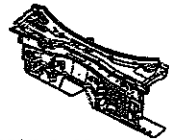

PICTORIAL INDEX

<p>1 0900</p>  <p>KEY SETS</p>	<p>2</p>	<p>3 5100</p>  <p>HEAD LAMPS</p>	<p>4 5103</p>  <p>HEAD LAMP RETRACTORS</p>	<p>5 5105</p>  <p>FRONT COMBINATION LAMPS</p>	<p>6 5110</p>  <p>REAR COMBINATION LAMPS</p>
<p>19 6704</p>  <p>WIRING HARNESS CLAMPS</p>	<p>20 6720</p>  <p>WINDSHIELD WASHER</p>	<p>21 6730</p>  <p>WINDSHIELD WIPERS</p>			<p>7 5120</p>  <p>LICENSE LAMPS</p>
<p>18 6703</p>  <p>WIRING HARNESSSES (DOOR, FLOOR/CEILING)</p>	<p>BODY (1/4)</p>  <p style="font-size: small; text-align: center;">As this illustration is prepared to be applicable to all models, some parts are different in specifications from parts listed in this parts Catalog.</p>				<p>8</p>
<p>17 6702</p>  <p>WIRING HARNESSSES (DASHBOARD)</p>					<p>9</p>
<p>16 6700</p>  <p>WIRING HARNESSSES (FRONT & REAR)</p>					<p>10 6600</p>  <p>SWITCHES & RELAYS (ENGINE)</p>
<p>15 6701</p>  <p>WIRING HARNESSSES (ENGINE & T/MISSION)</p>	<p>14 6640</p>  <p>AUTO CRUISE CONTROL SYSTEM</p>	<p>13 6635</p>  <p>DOOR SWITCH & HORNS</p>	<p>12 6630</p>  <p>RELAYS & UNIT (BODY)</p>	<p>11</p>	

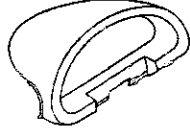
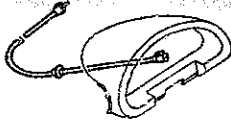
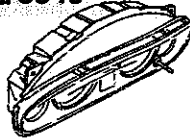
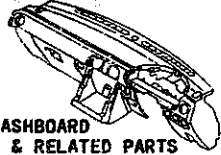
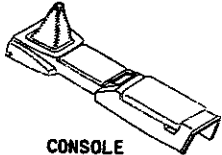
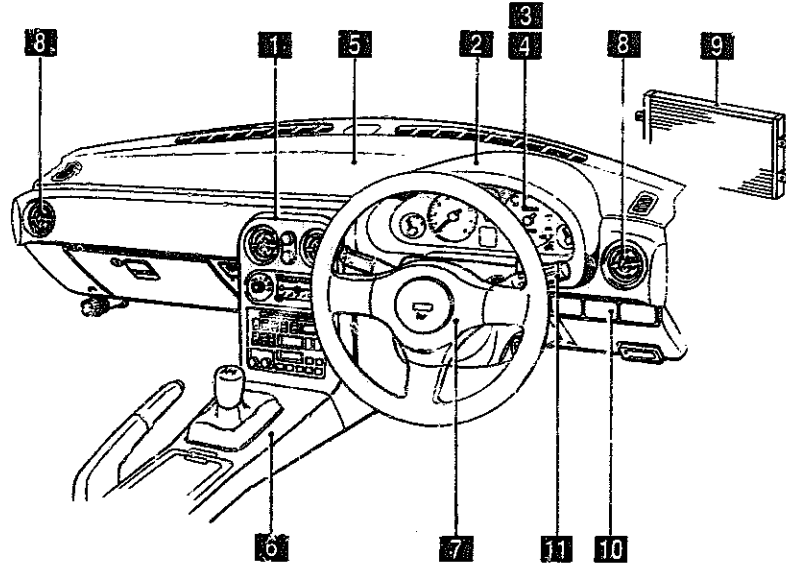

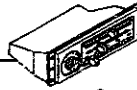
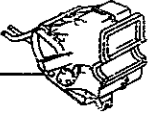

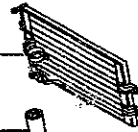

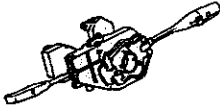
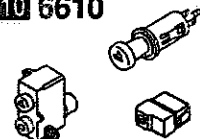
PICTORIAL INDEX

<p>1 5000</p>  <p>FRONT BUMPER</p>	<p>2 5010</p>  <p>REAR BUMPER</p>	<p>3 5030</p>  <p>WINDOW MOULDING & COWL GRILLES</p>	<p>4 5170</p>  <p>ORNAMENTS</p>	<p>5 5180</p>  <p>REAR FINISHER</p>	<p>6 5230</p>  <p>BONNET</p>
<p>BODY (2/4)</p> 					
<p>19 6330</p>  <p>SUNROOF</p>					<p>7 5260</p>  <p>TRUNK LID</p>
<p>18 6300</p>  <p>WINDOW GLASSES</p>					<p>8 5310</p>  <p>FRONT PANELS</p>
<p>17 5840</p>  <p>FRONT DOOR TRIMS & RELATED PARTS</p>					<p>9 5320</p>  <p>FENDER & WHEEL APRON PANELS</p>
<p>16 5830</p>  <p>FRONT DOOR MECHANISMS</p>	<p>15 5800</p>  <p>FRONT DOORS</p>	<p>14 5390</p>  <p>FLOOR ATTACHMENTS</p>	<p>13 5380</p>  <p>FLOOR ATTACHMENTS (HOLE COVERS)</p>	<p>12 5370</p>  <p>FLOOR PANELS</p>	<p>11 5340</p>  <p>SIDE PANELS</p>
<p>10 5330</p>  <p>DASH & COWL PANELS</p>					

PICTORIAL INDEX

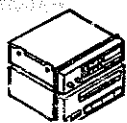
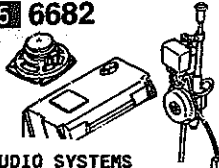
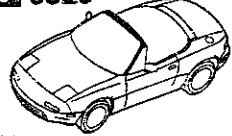
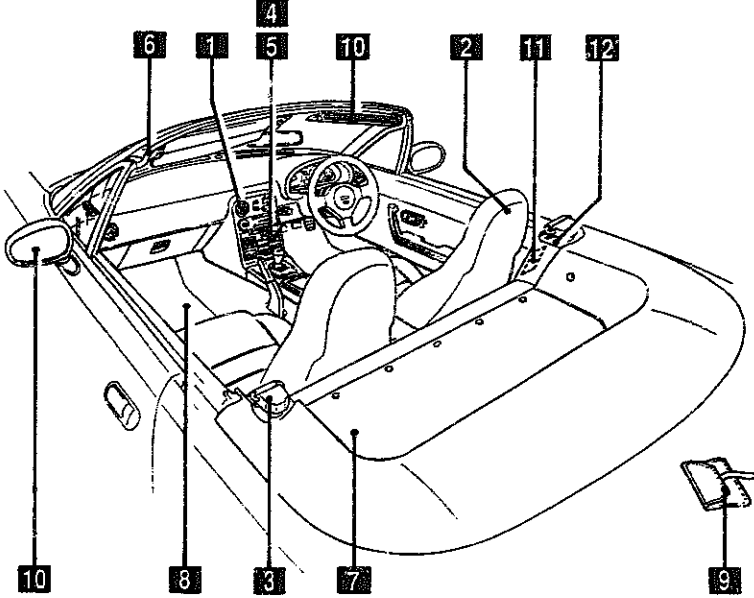
<p>1 5500</p>  <p>DASHBOARD EQUIPMENTS</p>	<p>2 5520</p>  <p>METER HOOD</p>	<p>3 5530</p>  <p>SPEEDOMETER CABLE</p>	<p>4 5540</p>  <p>METER COMPONENTS</p>	<p>5 5560</p>  <p>DASHBOARD & RELATED PARTS</p>	<p>6 5570</p>  <p>CONSOLE</p>
<h3 style="margin: 0;">BODY (3/4)</h3>					
					
<p>7 5795</p>  <p>AIR BAG</p>					
<p>8</p> <p>6115 </p> <p>6110 </p> <p>6100 </p> <p>6120 </p> <p>HEATER</p>					
<p>9</p> <p>6130 </p> <p>6140 </p> <p>6150 </p> <p>AIR CONDITIONER</p>					
<p>11 6611</p>  <p>COMBINATION SWITCH</p>					
<p>10 6610</p>  <p>DASHBOARD SWITCHES</p>					

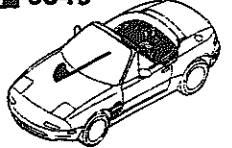
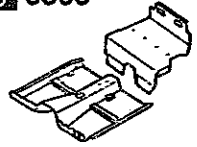
PICTORIAL INDEX

1 5580  VENTILATOR	2 5700  SEATS	3 5790  SEAT BELTS	4 6680  AUDIO SYSTEMS (RADIO & TAPE DECK)	5 6682  AUDIO SYSTEMS (ANTENNA & SPEAKER)	6 6820  FRONT HEADER TRIM & PILLAR TRIMS
<h3 style="margin: 0;">BODY (4/4)</h3> 					
As this illustration is prepared to be applicable to all models, some parts are different in specifications from parts listed in this parts Catalog.					
				12 7250  QUARTER WINDOW & TRIMS	11 6930  CAUTION PLATES & LABELS
					7 6840  TRIMS & SCUFF PLATES
					8 6860  FLOOR MATS & PADS
					9 6870  SERVICE TOOLS
					10 6900  VISORS, ASSIST HANDLES & MIRRORS

SECTION NAME INDEX (ENGINE)

LD.NO	SEC.NO	SECTION NAME	LD.NO	SEC.NO	SECTION NAME	LD.NO	SEC.NO	SECTION NAME
1-C03	1000	ENGINE & GASKET SETS	1-M09	1960	GASKET & SEAL KIT (AUTOMATIC)			
1-E03	1010	CYLINDER HEAD & COVER						
1-H03	1030	CYLINDER BLOCK						
1-I03	1040	OIL PAN & TIMING COVER						
1-K03	1100	PISTON, CRANKSHAFT & FLYWHEEL						
1-N03	1200	VALVE SYSTEM						
1-D04	1300	INLET MANIFOLD						
1-E04	1310	EXHAUST MANIFOLD						
1-F04	1320	FUEL SYSTEM						
1-H04	1325	FUEL DISTRIBUTOR						
1-I04	1330	AIR CLEANER						
1-K04	1364	THROTTLE BODY						
1-L04	1370	EMISSION CONTROL SYSTEM (INLET SIDE)						
1-H04	1400	OIL PUMP & FILTER						
1-D05	1500	COOLING SYSTEM						
1-G05	1500	BRACKET, PULLEY & BELT						
1-C06	1600	CLUTCH DISC & COVER (MANUAL)						
1-D06	1700	TRANSMISSION CASE (MANUAL)						
1-E06	1710	TRANSMISSION GEARS (MANUAL)						
1-J06	1720	CHANGE CONTROL SYSTEM (MANUAL)						
1-M06	1800	ENGINE ELECTRICAL SYSTEM						
1-C07	1830	ALTERNATOR						
1-E07	1840	STARTER (MT)						
1-G07	1840 A	STARTER (AT)						
1-I07	1850	BATTERY						
1-J07	1910	TORQUE CONVERTER, OIL PUMP & PIPINGS (AUTOMATIC)						
1-M07	1920	TRANSMISSION CASE & MAIN CONTROL SYSTEM (AUTOMATIC)						
1-F08	1925	CONTROL VALVE (AUTOMATIC)						
1-M08	1930	CLUTCHES & PLANETARY GEARS (AUTOMATIC)						
1-H09	1940	GOVERNOR, LOW & REVERSE PISTON (AUTOMATIC)						
1-K09	1950	MANUAL LINKAGE SYSTEM (AUTOMATIC)						

SECTION NAME INDEX (CHASSIS)

LD.NO	SEC.NO	SECTION NAME	LD.NO	SEC.NO	SECTION NAME	LD.NO	SEC.NO	SECTION NAME
1-C11	2505	REAR PROPELLER SHAFT	1-C15	4300A	BRAKE PEDALS (AUTOMATIC TRANSMISSION)			
1-D11	2550	REAR DRIVE SHAFT	1-E15	4340	BRAKE MASTER CYLINDER & POWER BRAKE (W/O ANTI LOCK BRAKE SYSTEM)			
1-E11	2600	REAR AXLE	1-G15	4340 A	BRAKE MASTER CYLINDER & POWER BRAKE (ANTI LOCK BRAKE SYSTEM)			
1-F11	2610	REAR BRAKE MECHANISMS	1-I15	4360	BRAKE PIPINGS (W/O ANTI LOCK BRAKE SYSTEM)			
1-H11	2710	REAR DIFFERENTIALS (NORMAL DIFF.)	1-K15	4360 A	BRAKE PIPINGS (ANTI LOCK BRAKE SYSTEM)			
1-L11	2710 A	REAR DIFFERENTIALS (LIMITED SLIP DIFF.)	1-M15	4370	ANTILOCK BRAKE SYSTEM			
1-C12	2800	REAR SUSPENSION MECHANISMS	1-C16	4400	PARKING BRAKE SYSTEM			
1-D12	2801	REAR SPRING & DAMPER	1-E16	4500	FUEL PIPINGS			
1-E12	2810	REAR STABILIZER	1-G16	4600	CHANGE CONTROL SYSTEM (AT)			
1-F12	2830	REAR LOWER ARMS & SUB FRAME						
1-H12	3200	STEERING WHEEL						
1-I12	3210	STEERING COLUMN & SHAFTS						
1-J12	3220	STEERING GEAR (W/O POWER STEERING)						
1-L12	3220 A	STEERING GEAR (W/ POWER STEERING)						
1-C13	3240	POWER STEERING SYSTEM						
1-E13	3300	FRONT AXLE (W/O ANTI LOCK BRAKE SYSTEM)						
1-F13	3300 A	FRONT AXLE (ANTI LOCK BRAKE SYSTEM)						
1-G13	3310	FRONT BRAKE MECHANISMS						
1-H13	3400	FRONT SUSPENSION MECHANISMS						
1-J13	3401	FRONT SPRING & DAMPER						
1-K13	3410	CROSSMEMBER & STABILIZER						
1-L13	3700	TIRES & JACK						
1-C14	3900	ENGINE & T/MISSION MOUNTINGS						
1-D14	4000	EXHAUST SYSTEM						
1-E14	4140	CLUTCH RELEASE & MASTER CYLINDERS (MANUAL TRANSMISSION)						
1-F14	4145	CLUTCH PIPINGS (MANUAL TRANSMISSION)						
1-G14	4160	ACCELERATOR CONTROL SYSTEM						
1-H14	4200	FUEL TANK						
1-K14	4210	FUEL LID OPENER						
1-L14	4300	CLUTCH & BRAKE PEDALS (MANUAL TRANSMISSION)						

SECTION NAME INDEX (BODY)

LD.NO	SEC.NO	SECTION NAME	LD.NO	SEC.NO	SECTION NAME	LD.NO	SEC.NO	SECTION NAME
2-C03	0900	KEY SETS	2-D11	6110	HEATER UNIT COMPONENTS	2-616	6930	CAUTION PLATES & LABELS
2-E03	5000	FRONT BUMPER	2-E11	6115	HEATER CONTROLS COMPONENTS	2-I16	7250	QUARTER WINDOW & TRIMS
2-H03	5010	REAR BUMPER	2-F11	6120	HEATER BLOWER COMPONENTS			
2-J03	5030	WINDOW MOULDING & COWL GRILLES	2-G11	6130	AIR CONDITIONER			
2-K03	5100	HEAD LAMPS	2-K11	6140	COMPRESSOR COMPONENTS (AIR CON DITIONER)			
2-L03	5103	HEAD LAMP RETRACTORS	2-M11	6150	COOLING UNIT (AIR CONDITIONER)			
2-C04	5105	FRONT COMBINATION LAMPS	2-N11	6300	WINDOW GLASSES			
2-E04	5110	REAR COMBINATION LAMPS	2-C12	6330	SUNROOF			
2-H04	5120	LICENSE LAMPS	2-N12	6600	SWITCHES & RELAYS (ENGINE)			
2-I04	5170	ORNAMENTS	2-E13	6610	DASHBOARD SWITCHES			
2-J04	5180	REAR FINISHER	2-F13	6611	COMBINATION SWITCH			
2-K04	5230	BONNET	2-G13	6630	RELAYS & UNIT (BODY)			
2-M04	5260	TRUNK LID	2-I13	6635	DOOR SWITCH & HORNS			
2-N04	5310	FRONT PANELS	2-J13	6640	AUTO CRUISE CONTROL SYSTEM			
2-C05	5320	FENDER & WHEEL APRON PANELS	2-K13	6680	AUDIO SYSTEMS (RADIO & TAPE DE CK)			
2-E05	5330	DASH & COWL PANELS	2-D14	6682	AUDIO SYSTEMS (ANTENNA & SPEAK ER)			
2-F05	5340	SIDE PANELS	2-G14	6700	WIRING HARNESSSES(FRONT & REAR)			
2-K05	5370	FLOOR PANELS	2-I14	6701	WIRING HARNESSSES(ENGINE & T/MI SSION)			
2-N05	5380	FLOOR ATTACHMENTS (HOLE COVERS)	2-J14	6702	WIRING HARNESSSES(DASHBOARD)			
2-C06	5390	FLOOR ATTACHMENTS	2-K14	6703	WIRING HARNESSSES(DOOR,FLOOR/CE ILING)			
2-C07	5500	DASHBOARD EQUIPMENTS	2-L14	6704	WIRING HARNESS CLAMPS			
2-E07	5520	METER HOOD	2-C15	6720	WINDSHIELD WASHER (W/O ANTI LOCK BRAKE SYSTEM)			
2-F07	5530	SPEEDOMETER CABLE	2-E15	6720 A	WINDSHIELD WASHER (ANTI LOCK BRAKE SYSTEM)			
2-G07	5540	METER COMPONENTS	2-H15	6730	WINDSHIELD WIPERS			
2-I07	5560	DASHBOARD & RELATED PARTS	2-J15	6740	WIPER MOTOR COMPONENTS(FRONT)			
2-L07	5570	CONSOLE	2-K15	6820	FRONT HEADER TRIM & PILLAR TRI MS			
2-C08	5580	VENTILATOR	2-L15	6840	TRIMS & SCUFF PLATES			
2-E08	5700	SEATS	2-N15	6860	FLOOR MATS & PADS			
2-E09	5790	SEAT BELTS	2-D16	6870	SERVICE TOOLS			
2-G09	5795	AIR BAG	2-E16	6900	VISORS,ASSIST HANDLES & MIRROR S			
2-J09	5800	FRONT DOORS						
2-M09	5830	FRONT DOOR MECHANISMS						
2-E10	5840	FRONT DOOR TRIMS & RELATED PAR TS						
2-C11	6100	HEATER						

CATLOG-NO= AUNA04-03

DATE. 1995-04

PAGE. 3

2-D 2

0900 KEY SETS

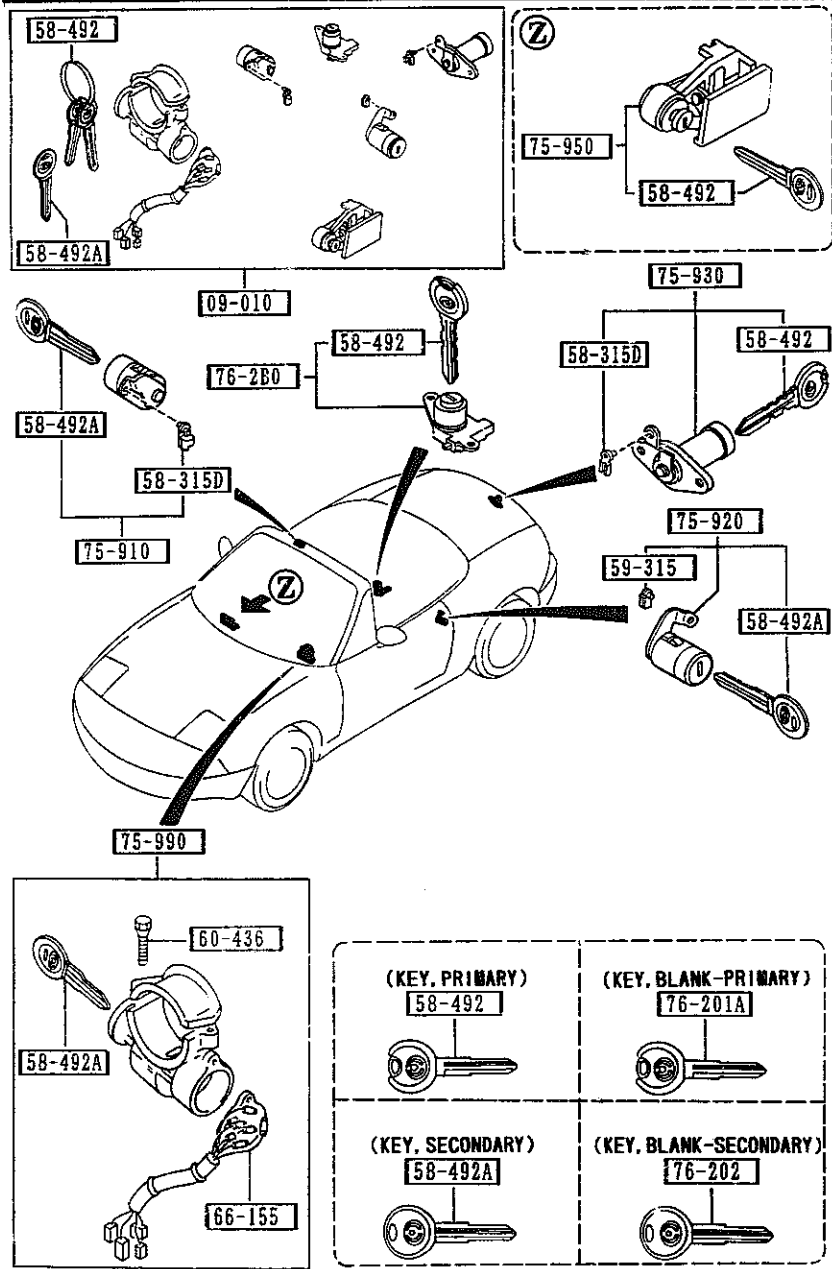

AUNA04

PART NO.	QTY	MODEL/RESTRICTION	MODEL/RESTRICTION	MODEL/RESTRICTION	FROM-TO
09-010		KEY SET			
NA75-09-010C	1	(MT)			-4201
00	INT-	NA3 NA4 NA5 BLACK			
88	INT-	NA4 NA5 TAN			
NA82-09-010A	1	(AT)			-4201
00	INT-	NA3 NA4 NA5 BLACK			
88	INT-	NA4 NA5 TAN			
NA75-09-010D	1	(MT)			4201-
00	INT-	NA5 NA4 NA5 BLACK			
NA82-09-010B	1	(AT)			4201-
00	INT-	NA3 NA4 NA5 BLACK			
58-315D		CLIP (R)			
G030-58-315	2				
58-492		KEY, PRIMARY			
FD01-58-492	2	KEY NO. IS REQUIRED			
58-492A		KEY, SECONDARY			
FD01-58-493	1	KEY NO. IS REQUIRED			
59-315		CLIP			
G030-59-315	1				
60-436		BOLT, SET			
H043-66-154	1				
66-155		SWITCH, IGNITION			
D001-66-151	1				
75-910		KEY SUB SET (R), DOOR			
NA14-76-210F	1				
75-920		KEY SUB SET (L), DOOR			
NA14-76-220F	1				
75-930		KEY SUB SET, TRUNK			
NA01-76-230C	1				
4201 NA3***-511601					

CAT. AUNAD4-05

1995-04

0900 KEY SETS

0900 -2 * KEY SETS

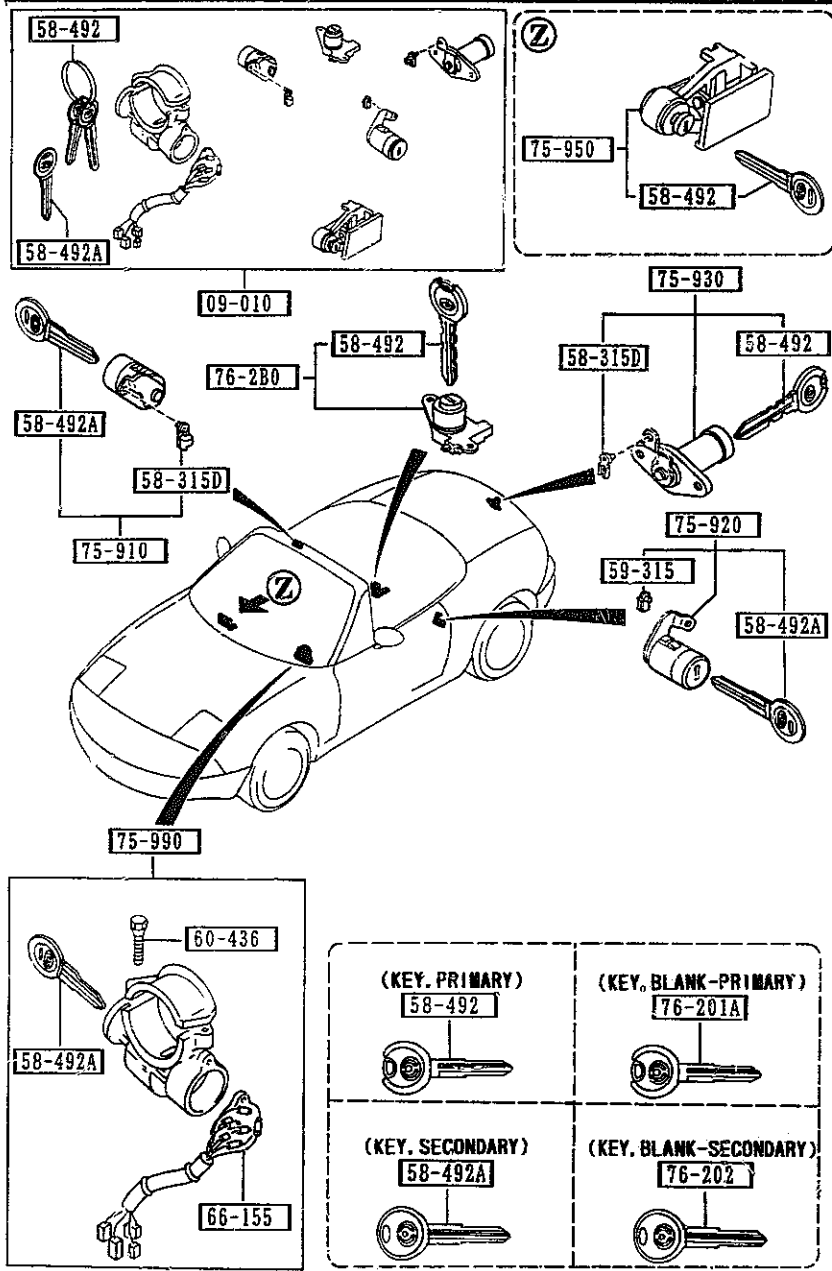

PART NO.	QTY	MODEL/RESTRICTION	MODEL/RESTRICTION	MODEL/RESTRICTION	FROM TO
75-950		KEY SUB SET, GLOVE			
NA75-76-250	1				
75-910		KEY SUB SET, ST. LOCK			
NA75-76-290	1 (HT)				
NAB1-76-290	1 (AT)				
76-280		KEY SUB SET, CONSOLE			
NAD1-76-280C	1				
76-201A		KEY, BLANK-PRIMARY			
FD01-76-201	1				
76-202		KEY, BLANK-SECONDARY			
FD01-76-202	1				

AUNA04

CAT. AUNA04-03

1995-04

5000 -1 FRONT BUMPER

5000 FRONT BUMPER

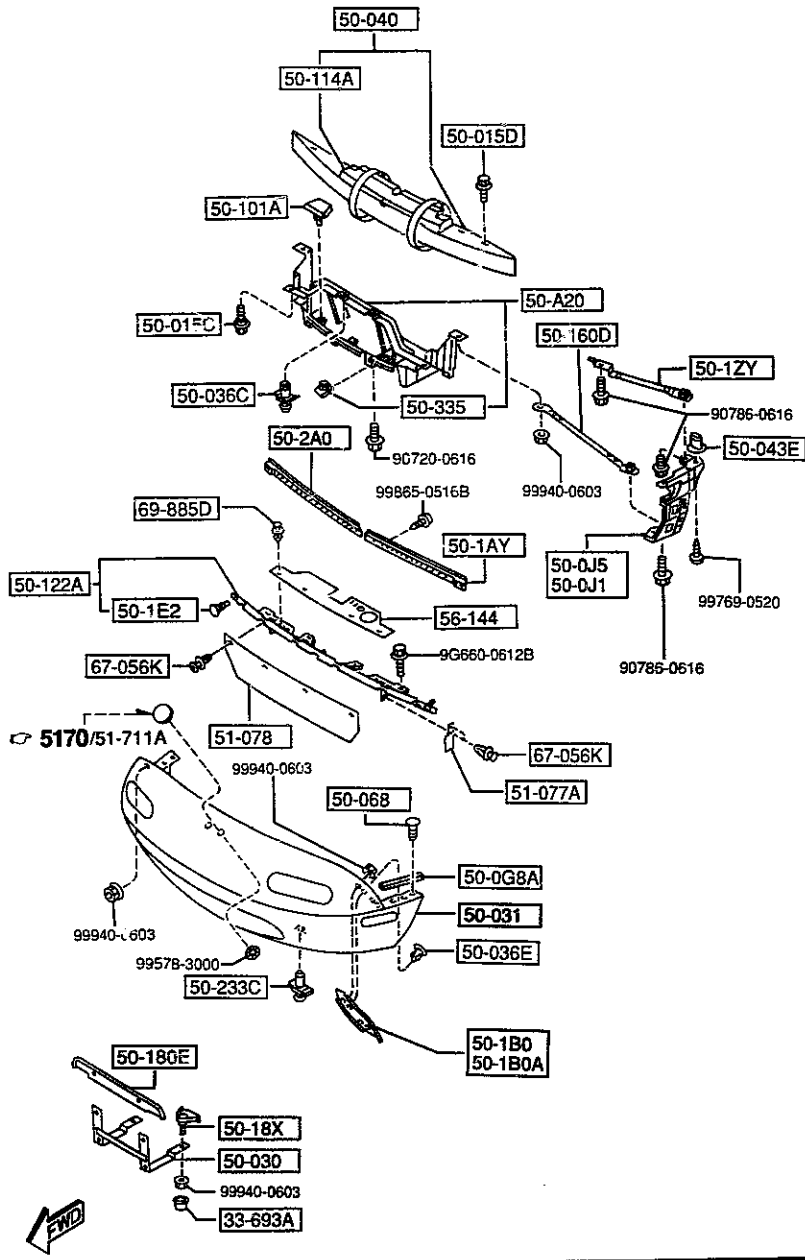

PART NO.	QTY	MODEL/RESTRICTION	MODEL/RESTRICTION	MODEL/RESTRICTION	FROM-TO
33-693A		CAP, BLEEDER SCREW			
0259-33-693	2				
50-A20		GUIDE, AIR			
NA01-50-A20A	1	(W/D A. LOCK BRAKE)			
NA23-50-A20	1	(A. LOCK BRAKE)			
50-0G8A		SEAL, RUBBER-FRONT BUMPER			
NA01-50-0G9	2				
50-0J1		RETAINER(R), FRONT BUMPER			
NA01-50-0J1	1				
50-0J5		RETAINER(L), FRONT BUMPER			
NA01-50-0J5	1				
50-015C		BOLT			
FB01-50-132	2				
50-015D		BOLT			
NA01-50-0Z2	8				
50-030		HOLDER, NO. PLATE			
NA01-50-180A	1				
50-031		BUMPER, FRONT			
NAV1-50-030	1	PAINT TO MATCH			
50-036C		FASTENER			
BF67-50-033	2				
50-036E		CLIP			
KA01-50-162	6				
50-040		REINFORCEMENT, BUMPER			
NA01-50-070	1	(W/D DAY RUNNING LAMP)			
50-043E		SLIDE'A', BUMPER			
B092-50-032	2				

AUNA04

CAT. AUNA04-05

1995-04

5000 FRONT BUMPER

5000 -3 * FRONT BUMPER

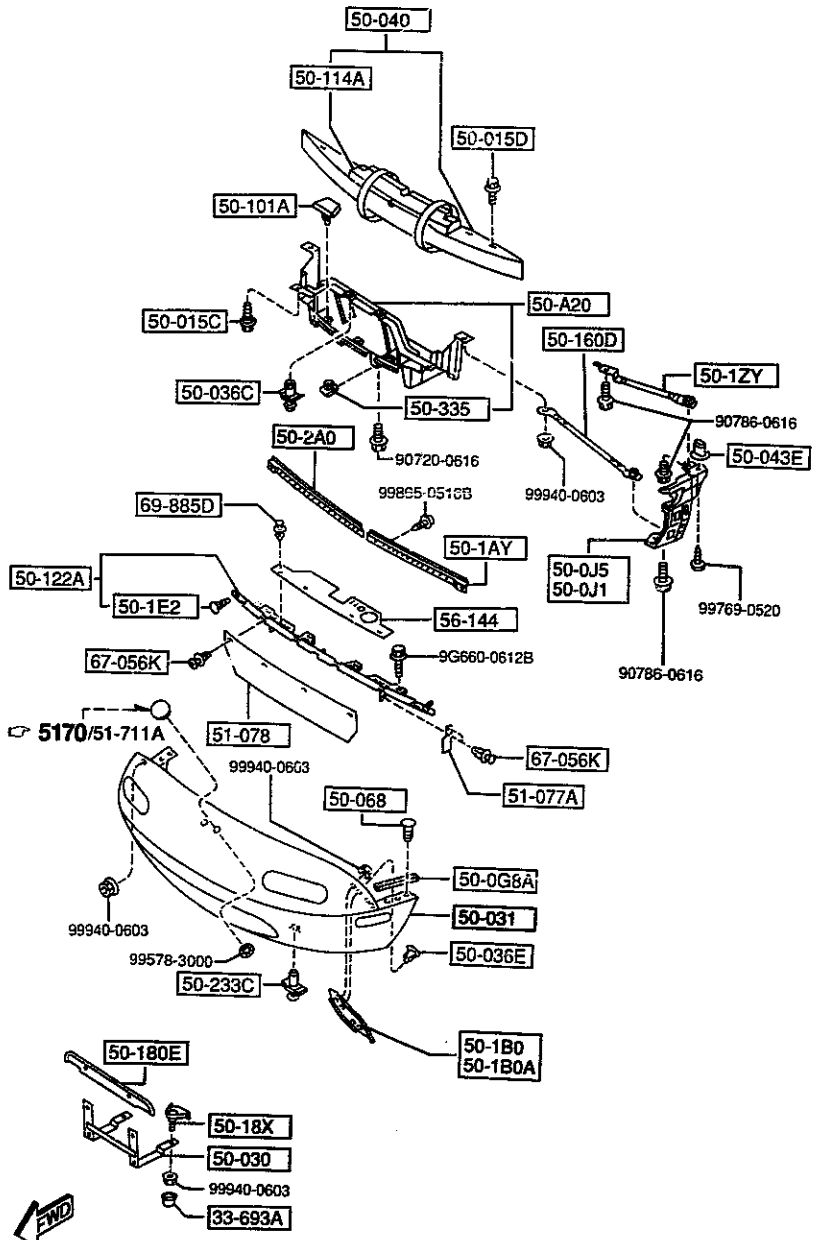

PART NO.	QTY	MODEL/RESTRICTION	MODEL/RESTRICTION	MODEL/RESTRICTION	FROM-TO
50-233C		FASTENER, REAR BUMPER			
BF82-50-233	2				
50-335		NUT, CLIP			
FB01-50-133C	4				
51-077A		SEAL, SIDE			
NA75-50-0K8	2				
51-078		SEAL, LOWER			
NA75-50-0K6A	1				
56-144		SEAL, BUMPER			
NA75-50-0K7A	1				
67-056K		RIVET			
UB39-50-795	8				
69-885D		FASTENER			
NA01-56-145	4				

AUNA04

CAT. AUNA04-03

1995-04

5010 REAR BUMPER

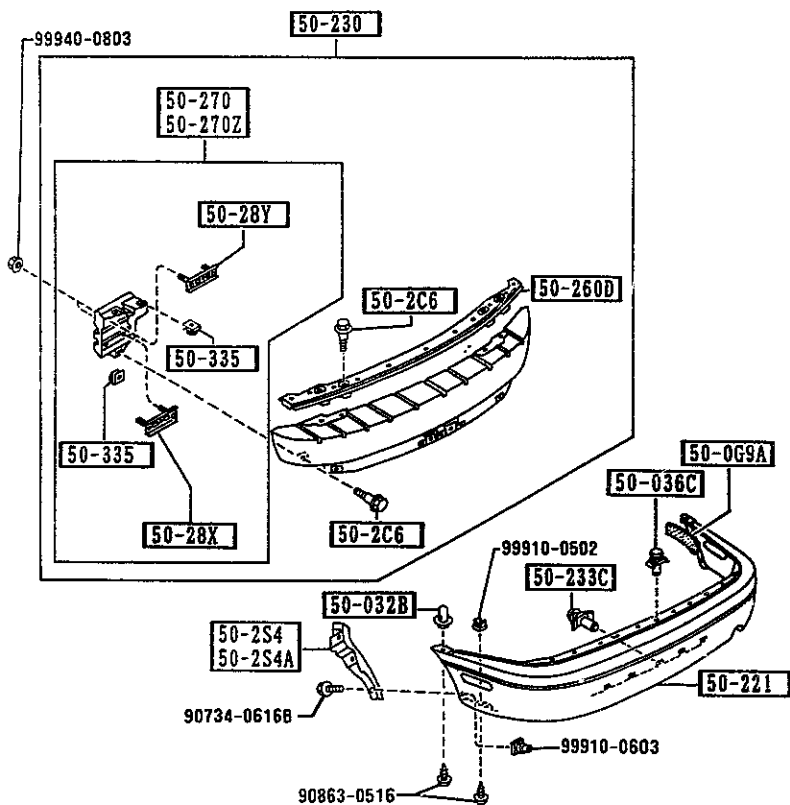

5010 -1 REAR BUMPER

PART NO.	QTY	MODEL/RESTRICTION	MODEL/RESTRICTION	MODEL/RESTRICTION	FROM-TO
50-069A		SEAL, RUBBER-REAR BUMPER			
NA01-50-068	2				
50-032B		SLIDE'UP.', BUMPER			
GJ21-50-032	2				
50-036C		FASTENER			
BF67-50-033	11				
50-2C6		BOLT			
NA01-50-2C6	6				
50-2S4		SHIELD(R), SPLASH-R. BUMPER			
NA01-50-2S4	1				
50-2S4A		SHIELD(L), SPLASH-R. BUMPER			
NA01-50-2S5	1				
50-221		BUMPER, REAR			
NAV1-50-220A	1	PAINT TO MATCH			
50-230		REINFORCEMENT, BUMPER			
NA01-50-260	1	(W/O DAY RUNNING LAMP)			
50-233C		FASTENER, REAR BUMPER			
BF82-50-233	5				
50-260D		RETAINER, R. BUMPER			
NA01-50-2J0	1				
50-270		STAY(R), RR. BUMPER			
NA01-50-280A	1				
50-270Z		STAY(L), RR. BUMPER			
NA01-50-290A	1				
50-28X		PLATE SET			
NA01-50-28XC	2				

AUNA04

CAT. AUNA04-03

1995-04

5010 -2 * REAR BUMPER

5010 REAR BUMPER



PART NO.	QTY	MODEL/RESTRICTION	MODEL/RESTRICTION	MODEL/RESTRICTION	FROM-TO
50-28Y		PLATE SET			
NA01-50-28YC	2				
50-335		NUT, CLIP			
NA01-50-133	6				

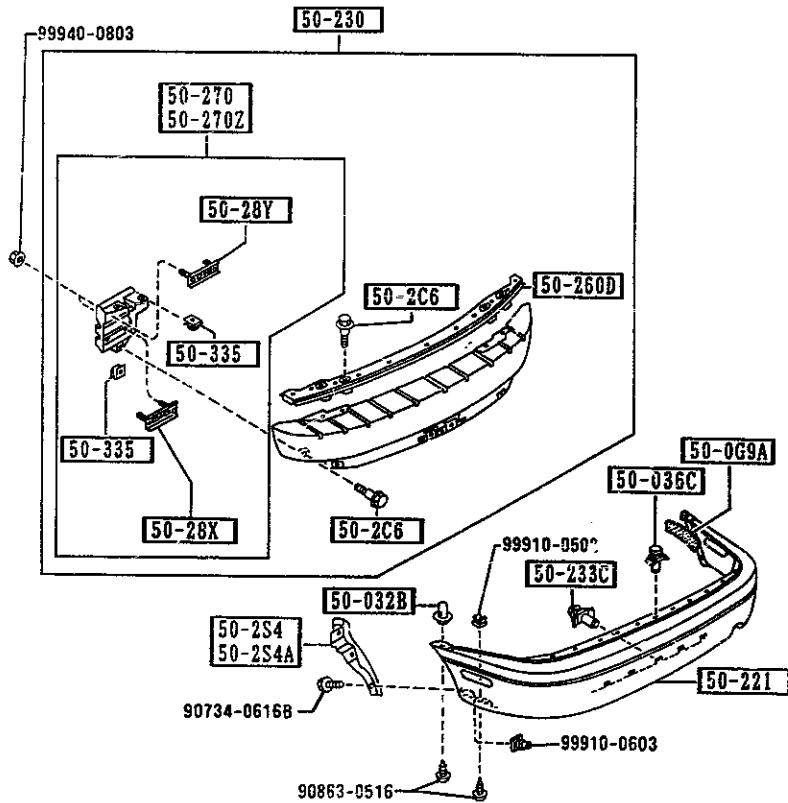

5030 WINDOW MOULDING & COWL GRILLES

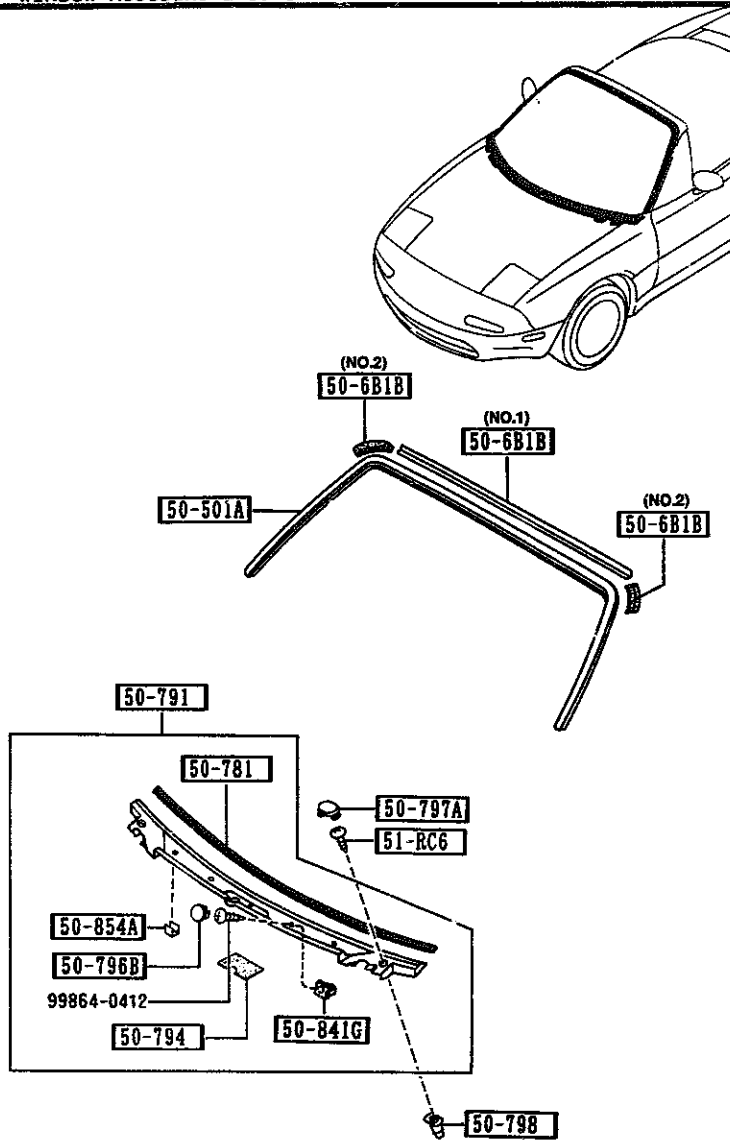

PART NO.	QTY	MODEL/RESTRICTION	MODEL/RESTRICTION	MODEL/RESTRICTION	FROM-TO
50-501A		MOULD(UP),FRT.WINDOW			
NA01-50-601	1				
50-6B1B		PROTR,MOULD-FRT WIND OW			
NA01-50-6B1	1 (ILLUST. NO.1)				
NA01-50-6B2	2 (ILLUST. NO.2)				
50-781		PROTECTOR,COWL GRILL E			
NA01-50-792A	1				
50-791		GRILLE,COWL			
NA01-50-790E	1				
50-794		PROTECTOR			
NA01-50-788	1				-3C01
50-796B		CAP			
B455-50-796A	5				
50-797A		CAP			
NA01-50-797A	2				
50-798		SCREW,GROMMET			
NA01-50-798	2				
50-841G		GROMMET,SCREW			
NA01-51-789	5				
50-854A		PROTECTOR			
NA01-50-794	4				
51-RC6		SCREW,SIDE GARNISH			
H272-51-RC6	2				

3C01 NA3***-507607

5100 HEAD LAMPS

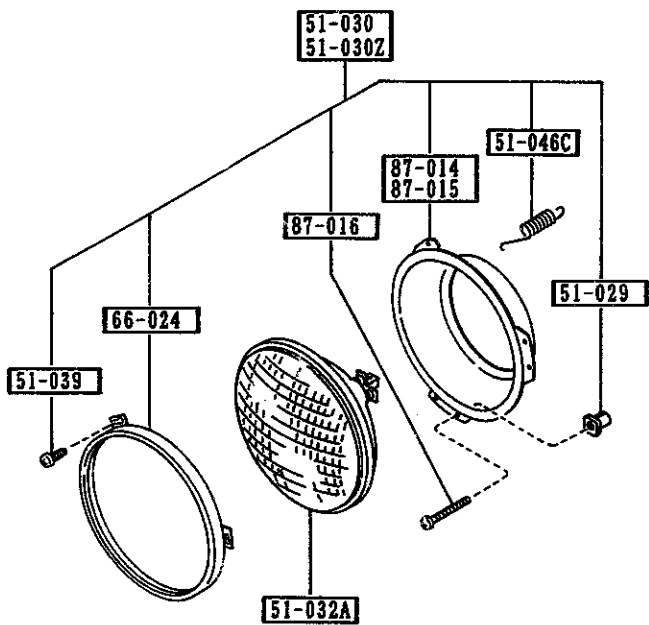

PART NO.	QTY	MODEL/RESTRICTION	MODEL/RESTRICTION	MODEL/RESTRICTION	FROM-TO
51-029		GROMMET, SCREW			
0483-66-061A	4				
51-030		LAMP SET(R), HEAD			
8BN1-51-030	1				
51-030Z		LAMP SET(L), HEAD			
8BN1-51-040	1				
51-032A		UNIT, HEAD LAMP			
NA02-51-031	2				
51-039		SCREW			
B481-51-0E3	6				
51-046C		SPRING			
NA01-51-046	2				
66-024		RING, RETAINING			
NA01-51-033	2				-4110
AN(NA01-51-033A)					
NA01-51-033A	2				4110-
87-014		RING(R) MOUNTING			
NA01-51-032	1				
87-015		RING(L) MOUNTING			
NA01-51-034	1				
87-016		SCREW, ADJUST			
NA01-51-037	4				

4110 NA3*5F-509641



5103 HEAD LAMP RETRACTORS

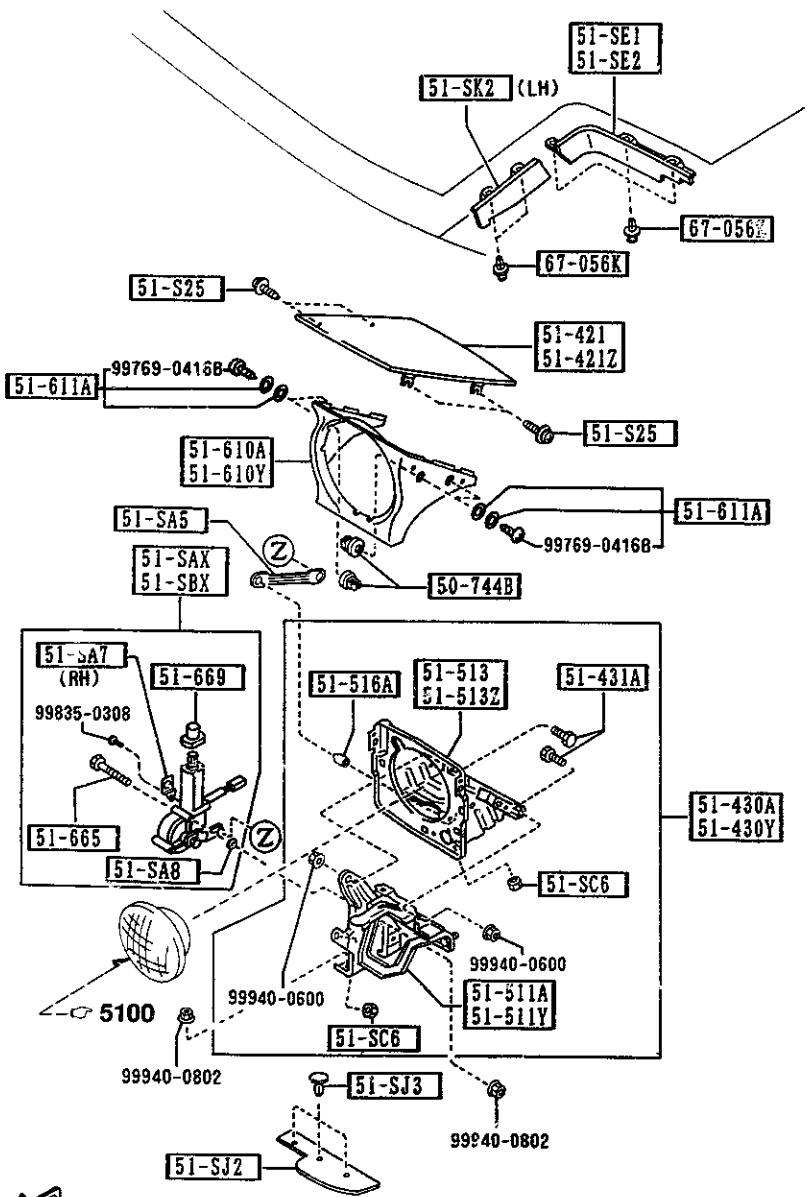

PART NO.	QTY	MODEL/RESTRICTION	MODEL/RESTRICTION	MODEL/RESTRICTION	FROM-TO
50-744B		GROMMET, SCREW			
B481-50-744	8				
51-SAX		MOTOR(R), RETRACTABLE HEAD			
NA01-51-SAX	1				
51-SA5		ROD, RETRACTABLE			
NA01-51-SA5	2				
51-SA7		BRACKET, CLIP			
NA01-51-SA7	1				
51-SAB		WASHER			
NA01-51-SAB	6				
51-SBX		MOTOR(L), RETRACTABLE HEAD			
NA01-51-SBX	1				
51-SC6		NUT, STOPPER-LAMP HINGE			
KA01-51-SC6	4				
51-SE1		PROTECTOR(R), RETRA H /L			
NA01-51-SE1	1				
51-SE2		PROTECTOR(L), RETRA. H/L			
NA01-51-SE2	1				
51-SJ2		PROTECTOR(L), RETRA. FRONT (IN SPITE OF (L), THIS PART IS APPLICABLE TO BOTH RH&LH SIDE)			
NA01-51-SJ2	2				
51-SJ3		CLIP			
NA01-51-SJ3	6				
51-SK2		PROTECTOR(L), RETRA. SIDE			
NA01-51-SK2	1				
51-S25		BOLT, LAMP LID			
BS34-51-S25A	8				

AUNA04

CAT. AUNA04-03

1995-04

5103 HEAD LAMP RETRACTORS

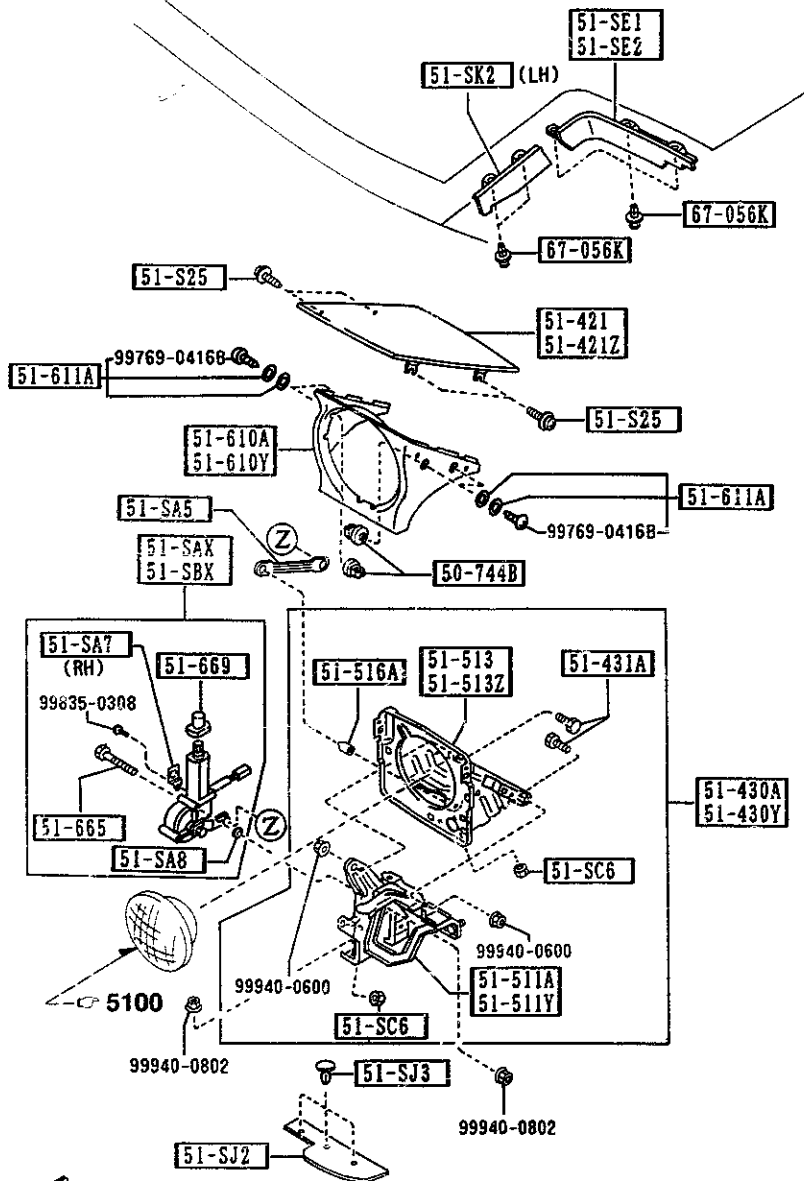

PART NO.	QTY	MODEL/RESTRICTION	MODEL/RESTRICTION	MODEL/RESTRICTION	FROM-TO
51-421		LID(R), LAMP			
NA01-51-SH1B	1				
51-421Z		LID(L), LAMP			
NA01-51-SH2B	1				
51-430A		HINGE(R), LID-LAMP			
NA01-51-SC0B	1				
51-430Y		HINGE(L), LID-LAMP			
NA01-51-SD0B	1				
51-431A		BOLT, HINGE			
KA01-51-SD7	4				
51-511A		BRACKET(P), HINGE-LAMP LID			
NA01-51-SC1A	1				
51-511Y		BRACKET(L), HINGE-LAMP LID			
NA01-51-SD1A	1				
51-513		HOUSING(R), LAMP-LID HINGE			
NA01-51-SC5B	1				
51-513Z		HOUSING(L), LAMP-LID HINGE			
NA01-51-SD5B	1				
51-514		CAP, HINGE-H.L. RETRACTABLE			
KA01-51-SD6	2				
51-610A		BEZEL(R), HEAD LAMP			
NA01-50-741	1				
51-610Y		BEZEL(L), HEAD LAMP			
NA01-50-751	1				
51-611A		SCREW, HEAD LAMP BEZEL			
B481-50-75X	8				
51-665		BOLT, MOTOR-RETRACT H/LAMP			
FB01-51-665	6				

5103 HEAD LAMP RETRACTORS

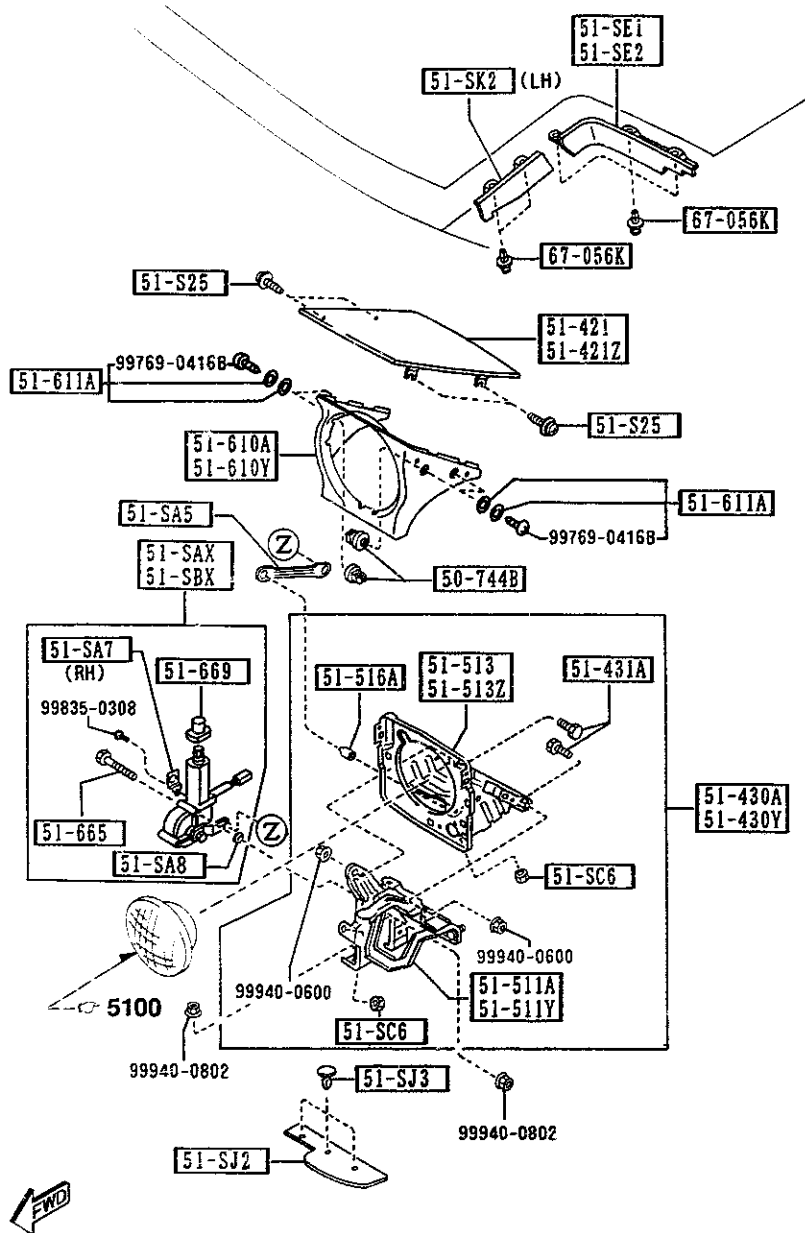

PART NO.	QTY	MODEL/RESTRICTION	MODEL/RESTRICTION	MODEL/RESTRICTION	FROM TO
+-----+ 51-669 +-----+ NA01-51-669	2	BOOT, MOTOR-RETRACT H /L			
+-----+ 67-056K +-----+ UB39-50-795	8	RIVET			

AUNA04

CAT. AUNA04-03

1995-04

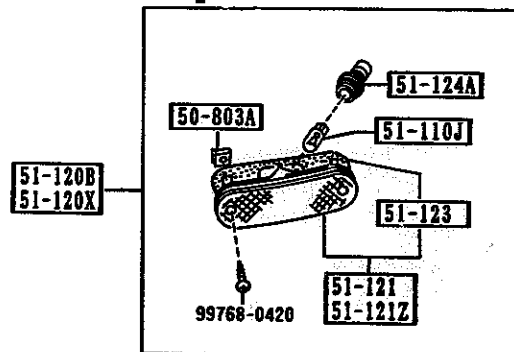
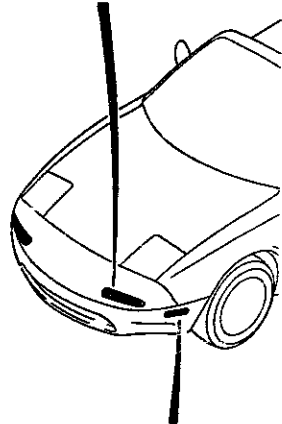
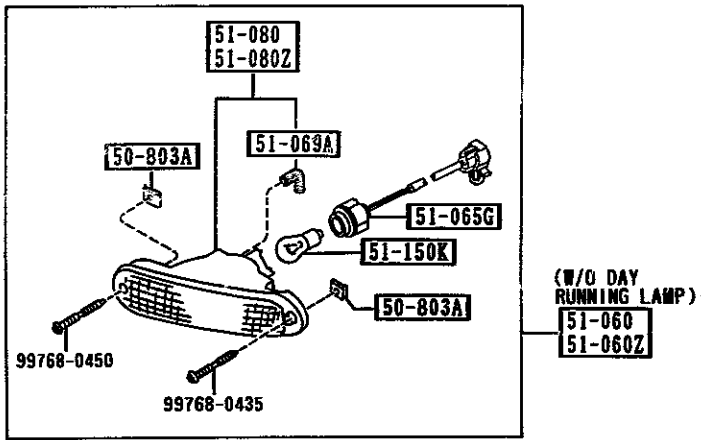

PART NO.	QTY	MODEL/RESTRICTION	MODEL/RESTRICTION	MODEL/RESTRICTION	FROM-TO
50-803A		NUT, SIDE PROTECTOR			
6158-50-803	8				
51-060		LAMP SET(R), FRT COMB			
8BN1-51-060	1	(W/O DAY RUNNING LAMP)			
51-060Z		LAMP SET(L), FRT COMB			
8BN1-51-070	1	(W/O DAY RUNNING LAMP)			
51-065G		SOCKET, F. COMB. LAMP			
NA01-51-064	2	(W/O DAY RUNNING LAMP)			
51-069A		TUBE, HEAD LAMP			
NA01-51-069	2				
51-080		LENS & HOUSING(R)			
HA01-51-06XA	1				
51-080Z		LENS & HOUSING(L)			
NA01-51-07XA	1				
51-110J		BULB			
99701-6038	2	12V 3.8W			
51-120B		LAMP SET(R), SIDE TURN			
8BN1-51-120	1				
51-120X		LAMP SET(L), SIDE TURN			
8BN1-51-130	1				
51-121		LENS & BODY(R)			
NA01-51-5EXA	1				
51-121Z		LENS & BODY(L)			
NA01-51-5FXA	1				
51-123		GASKET, SIDE TURN			
NA01-51-5D3A	2				

5105 FRONT COMBINATION LAMPS

5105 -2 * FRONT COMBINATION LAMPS

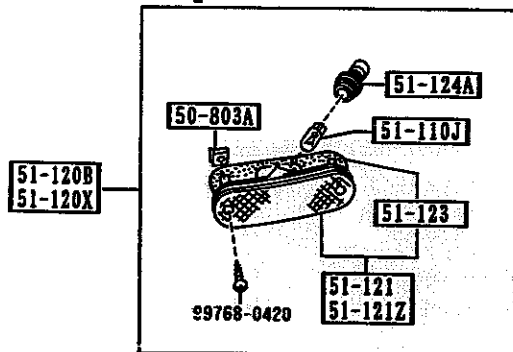
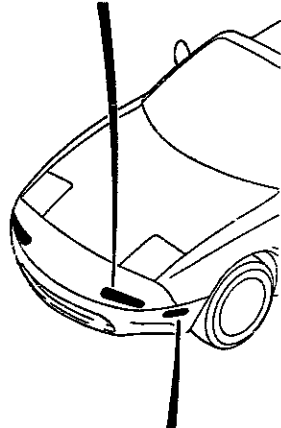
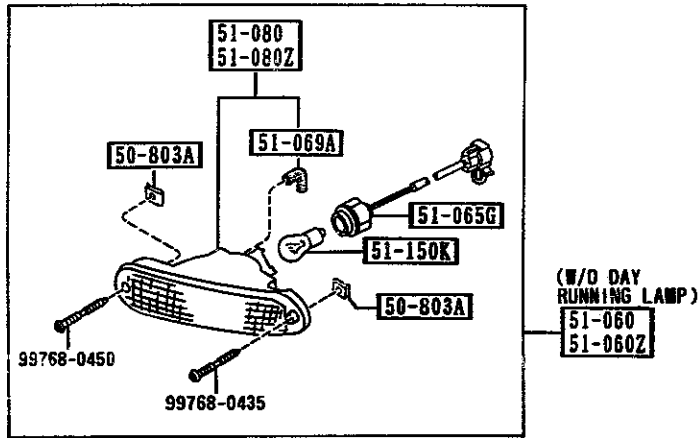

PART NO.	QTY	MODEL/RESTRICTION	MODEL/RESTRICTION	MODEL/RESTRICTION	FRON-TO
51-124A		SOCKET, SIDE TURN			
NA01-51-5E2	2				
51-150K		BULB			
99701-4278Y	2	A12V 27/8W			

AUNA04

CAT. AUNA04-03

1995-04

5110 REAR COMBINATION LAMPS

5110 -2 REAR COMBINATION LAMPS

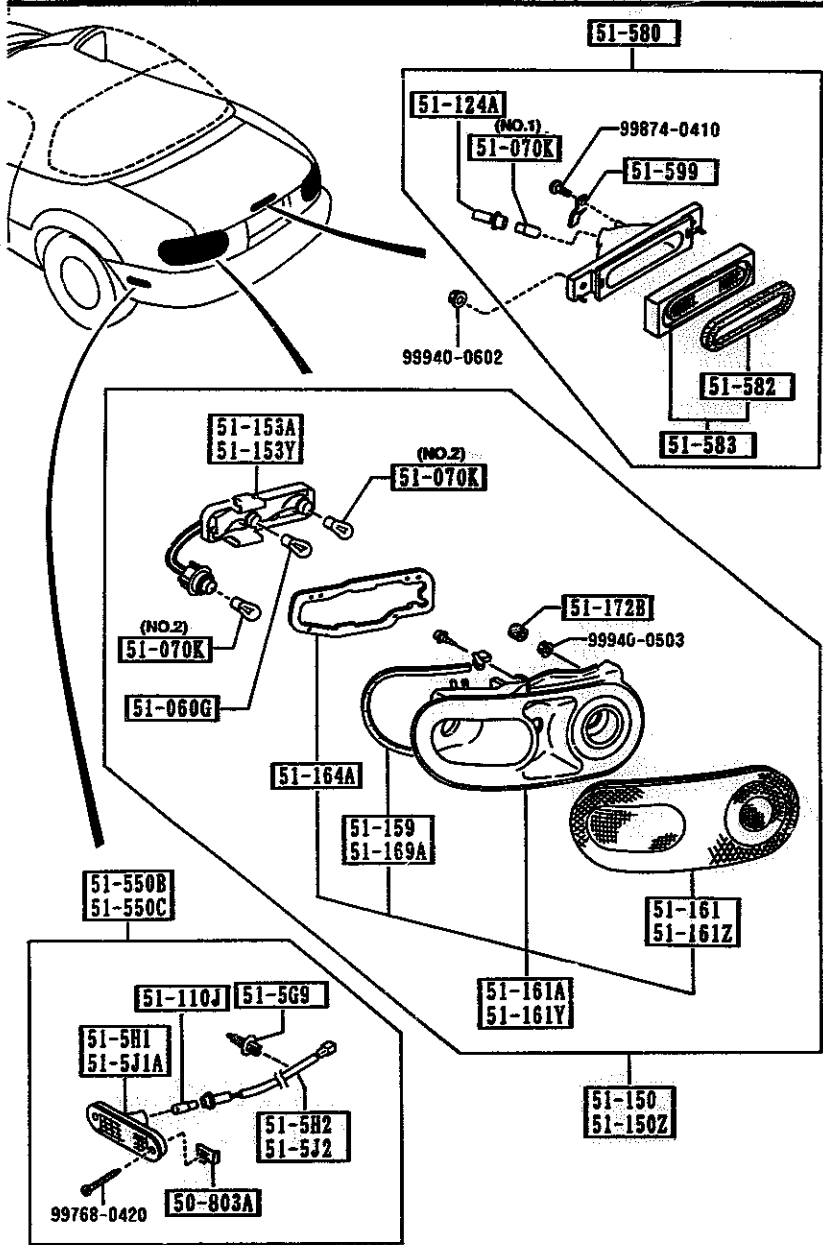

PART NO.	QTY	MODEL/RESTRICTION	MODEL/RESTRICTION	MODEL/RESTRICTION	FROM-TO
50-803A		NUT, SIDE PROTECTOR			
G158-50-803	4				
51-060G		BULB			
99701-4278	2	12V 27W/BW			
51-070K		BULB			
99700-7180	1	A12V 18.4W (ILLUST. NO.1)			
99701-3270	4	12V 27W (ILLUST. NO.2)			
51-110J		BULB			
99701-6038	2	12V 3.8W			
51-124A		SOCKET, SIDE TURN			
BJ38-51-584	1				
51-150		LAMP SET(R), RR. COMB.			
8BN1-51-150	1				
51-150Z		LAMP SET(L), RR. COMB.			
8BN1-51-160	1				
51-153A		SOCKET(R), RR. COMB.			
N001-51-155A	1				
51-153Y		SOCKET(L), RR. COMB.			
N001-51-165A	1				
51-159		PROTECTOR(R), 'A'			
NA01-51-159	1				
51-161		LENS(R), RR. COMB.			
NA01-51-15XB A (NA01-51-15XC)	1				
NA01-51-15XC	1				3901-
51-161A		LENS & BODY(R), RR CO MB.			
NA01-51-170B	1				
3901 NA3 EX -502360					

AUNA04

CAT. AUNA04-03

1995-04

5110 REAR COMBINATION LAMPS

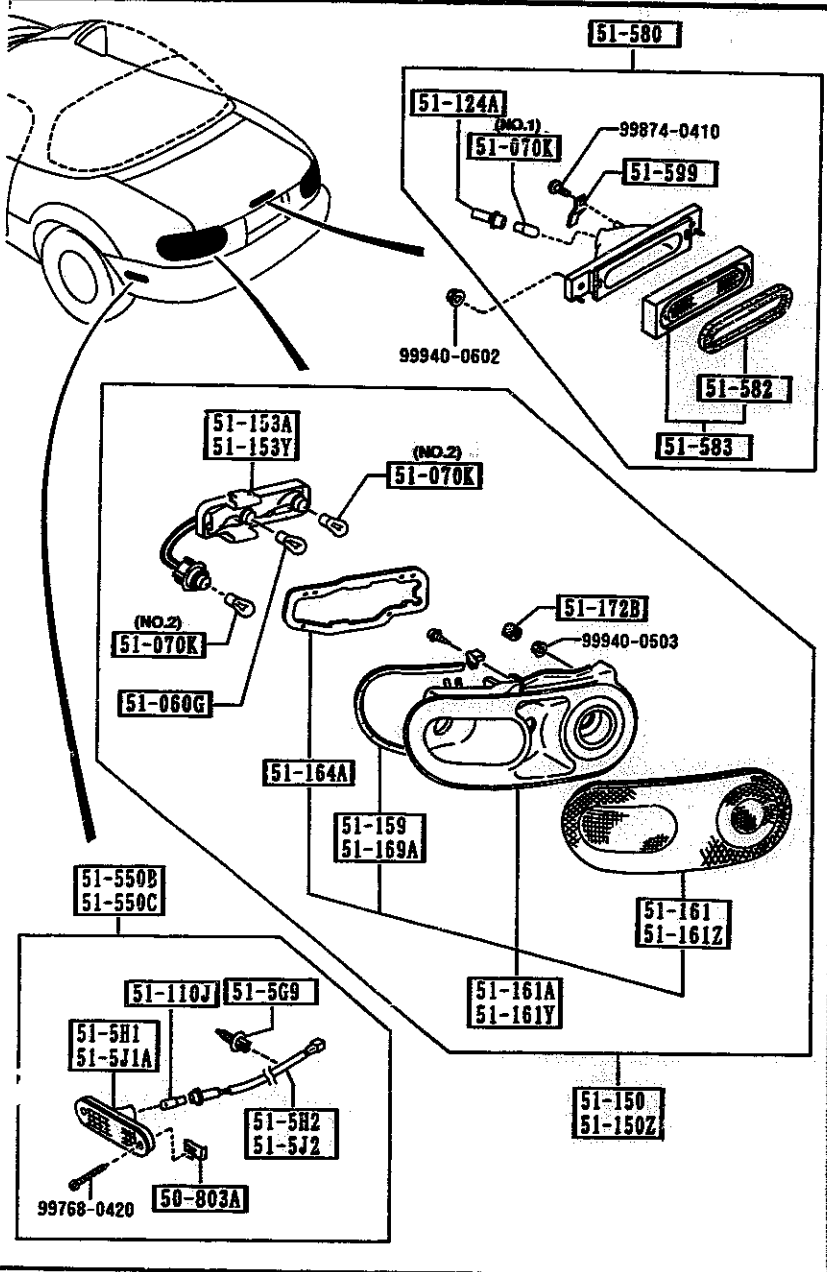

5110 -2 REAR COMBINATION LAMPS

PART NO.	QTY	MODEL/RESTRICTION	MODEL/RESTRICTION	MODEL/RESTRICTION	FROM-TO
51-161Y		LENS & BODY(L),RR CO			
NA01-51-180B	1	MB.			
51-161Z		LENS(L),RR.COMB.			
NA01-51-16XB	1				-3901
A (NA01-51-16XC)					
NA01-51-16XC	1				3901-
51-164A		GASKET,RR.COMB.			
NA01-51-158	2				
51-169A		PROTECTOR(L),*A*			
NA01-51-169	1				
51-172B		CAP			
6030-51-172	1				
51-569		CLIP			
NA01-51-569	8				
51-5H1		LENS & BODY(R),RR SI			
NA01-51-5H1C	1	DE TURN			
51-5H2		SOCKET(R),RR SIDE TU			
NA01-51-5H2A	1	RN			
51-5J1A		LENS & BODY(L),RR SI			
NA01-51-5J1C	1	DE TURN			
51-5J2		SOCKET(L),RR SIDE TU			
NA01-51-5J2A	1	RN			
51-550B		LAMP SET(R),SIDE TUR			
88N1-51-550	1	N-RR			
51-550C		LAMP SET(L),SIDE TUR			
38N1-51-560	1	N-RR			
51-580		LAMP,STOP-HI.MOUNT.			
NA01-51-580B	1				

3901 NA3333-502360

AUNAD4

CAT. AUNA04-03

1995-04

5110 REAR COMBINATION LAMPS

5110 -3 * REAR COMBINATION LAMPS

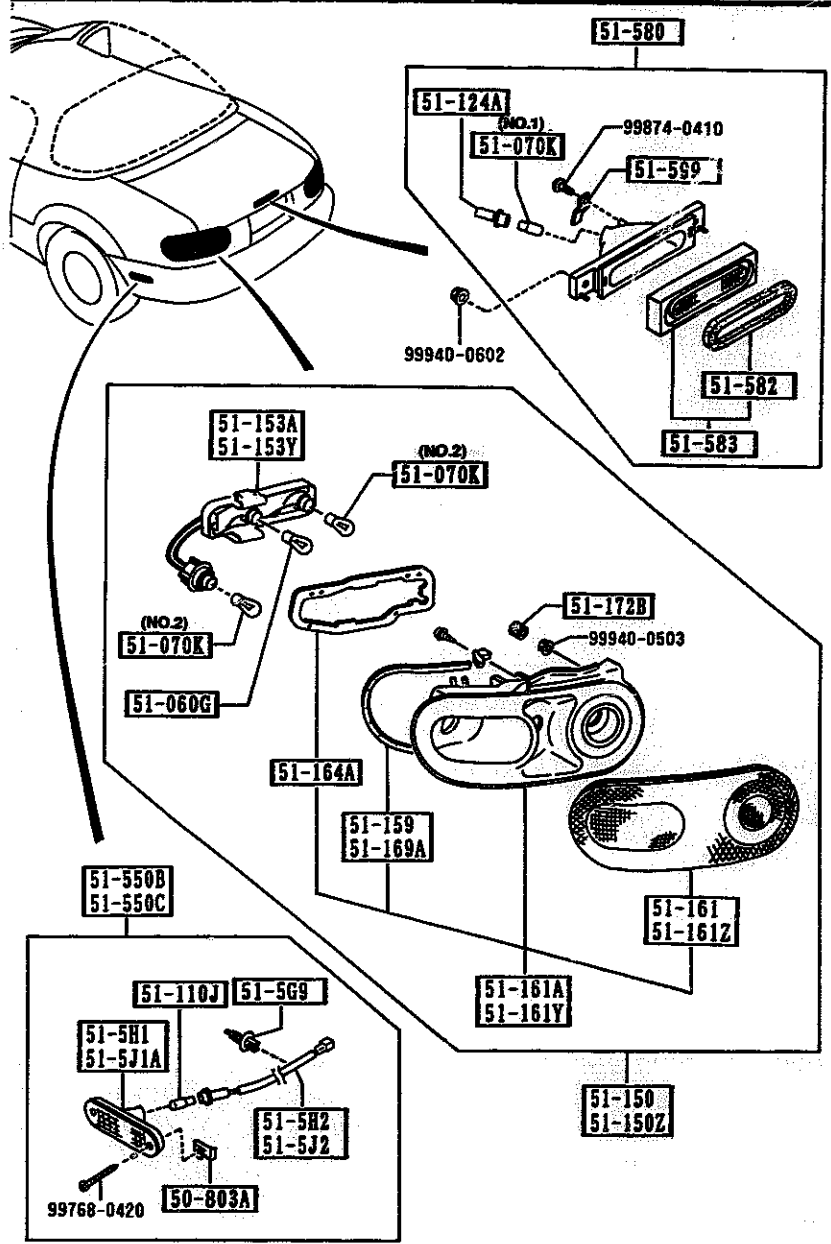

PART NO.	QTY	MODEL/RESTRICTION	MODEL/RESTRICTION	MODEL/RESTRICTION	FROM-TO
51-582 NA01-51-592B	1	GASKET, STOP LAMP-HI. MOUNT			
51-583 NA01-51-58XA	1	LENS, STOP LAMP-HI. MOUNT			
51-599 NA01-51-599	1	FASTENER, STOP LAMP-HI.			

AUNA04

CAT. AUNA04-03

1995-04

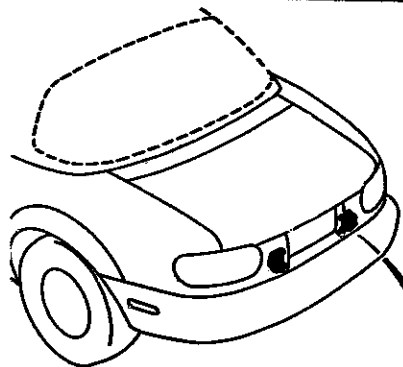

51-270

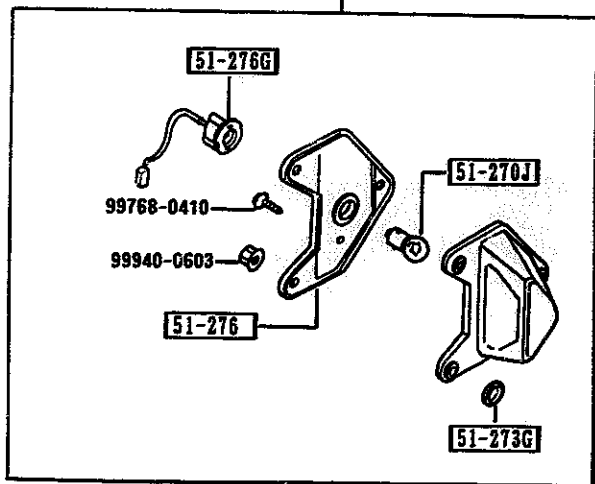

PART NO.	QTY	MODEL/RESTRICTION	MODEL/RESTRICTION	MODEL/RESTRICTION	FROM-TO
51-270		LAMP,LICENSE			
8BF1-51-270	2				
51-270J		BULB			
99701-2070	2	12V 7.5W			
51-2736		GASKET,LICENSE LAMP			
FB67-51-273	2				
51-276		SHADE,LAMP-LICENSE			
FB67-51-276	2				
51-276G		SOCKET,LICENSE LAMP			
FB67-51-272	2				

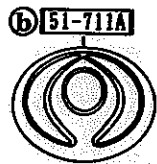
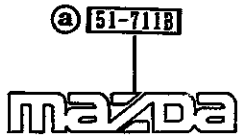
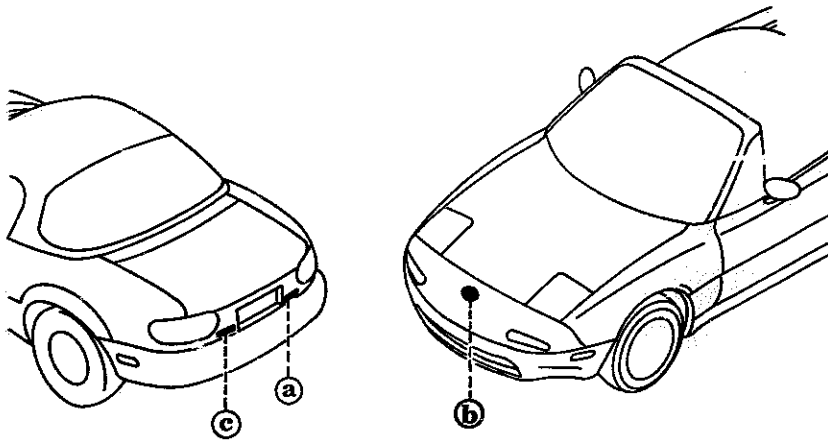

PART NO.	QTY	MODEL/RESTRICTION	MODEL/RESTRICTION	MODEL/RESTRICTION	FROM-TO
51-711A		ORNAMENT, FRONT			
BB1H-51-731	1				
51-711B		ORNAMENT, MAKER NAME-REAR			
MA01-51-711	1				
51-781		ORNAMENT, REAR			
MA01-51-721A	1				

5180 REAR FINISHER

5180 -1 * REAR FINISHER

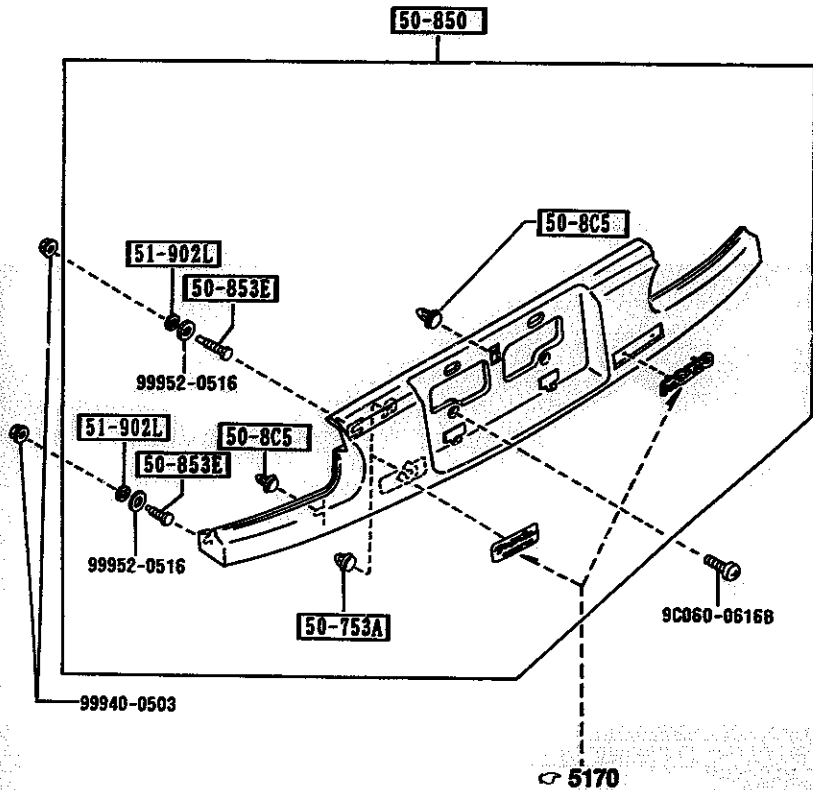

PART NO.	QTY	MODEL/RESTRICTION	MODEL/RESTRICTION	MODEL/RESTRICTION	FROM-TO
50-753A		FASTENER			
6043-50-753	4				
50-8C5		CLIP			
B467-50-8C5	3				
50-850		FINISHER, REAR			
NA01-50-850H	1				
M8	EXT-	M8 MONTEGO BLUE M			
PT	EXT-	PT CHAST WHITE			
PZ	EXT-	PZ BRILLIANT BLACK			
SU	EXT-	SU CLASSIC RED			
6W	EXT-	6W LAGUNA BLUE M.			
50-853E		BOLT, GARNISH-RR			
LA01-50-853	4				
51-902L		GASKET			
6032-51-914	4				

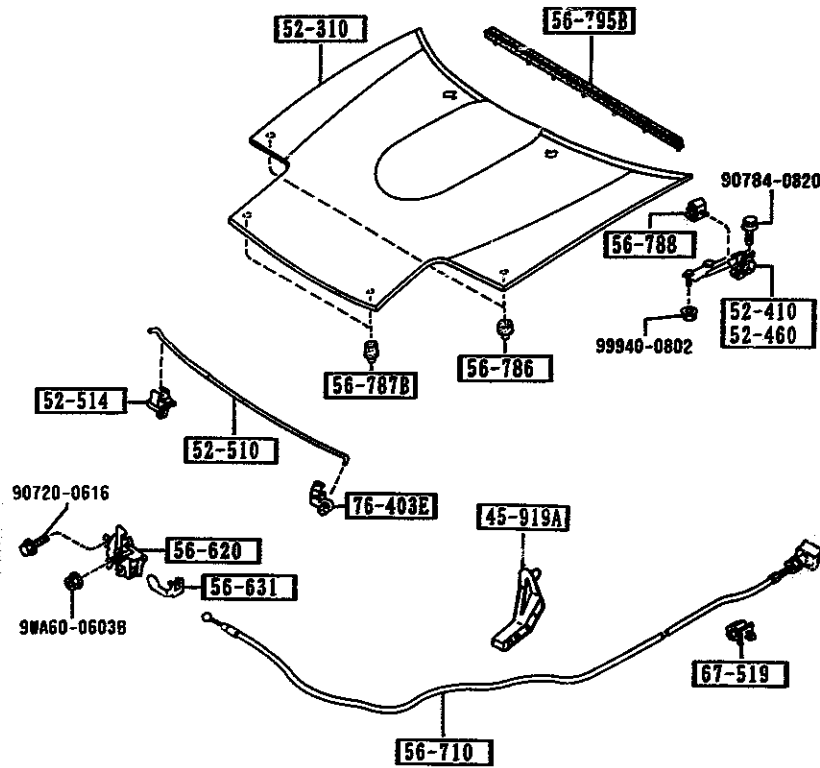

PART NO.	QTY	MODEL/RESTRICTION	MODEL/RESTRICTION	MODEL/RESTRICTION	FROM-TO
45-919A	1	HOLDER, PIPE			
MI15-45-916A	1				
52-310	1	BONNET			
MAY1-52-310B	1				
52-410	1	HINGE(R), BONNET			
NA01-52-410A	1				
52-460	1	HINGE(L), BONNET			
NA01-52-420A	1				
52-510	1	STAY, BONNET			
NA75-56-650A	1				
52-514	1	HOLDER, ROD			
6050-56-693A	1				
56-620	1	LOCK, BONNET			
NA01-56-620A	1				
56-631	1	FASTENER, BONNET RELEASE			
LA01-56-631	1				
56-710	1	WIRE, RELEASE-BONNET			
NA01-56-720D	1				
56-786	2	RUBBER(C), CUSHION-BONNET			
NA01-56-787	2				
56-787B	2	RUBBER, CUSHION-BONNET FRT			-4401
FB01-56-787A (FB01-56-787B)	2				4401-
FB01-56-787B	2				
56-788	2	RUBBER, CUSHION-BONNET RR			
NA01-56-78X	2				
56-795B	1	WEATHERSTRIP, BONNET-REAR			
NA01-56-760	1				

4401 NA3XXX-517818



PART NO.	QTY	MODEL/RESTRICTION	MODEL/RESTRICTION	MODEL/RESTRICTION	FROM-TO
67-519		CLIP, PIPE			
6030-67-519	1				
76-403E		HOLDER, ROD			
B692-52-518	1				

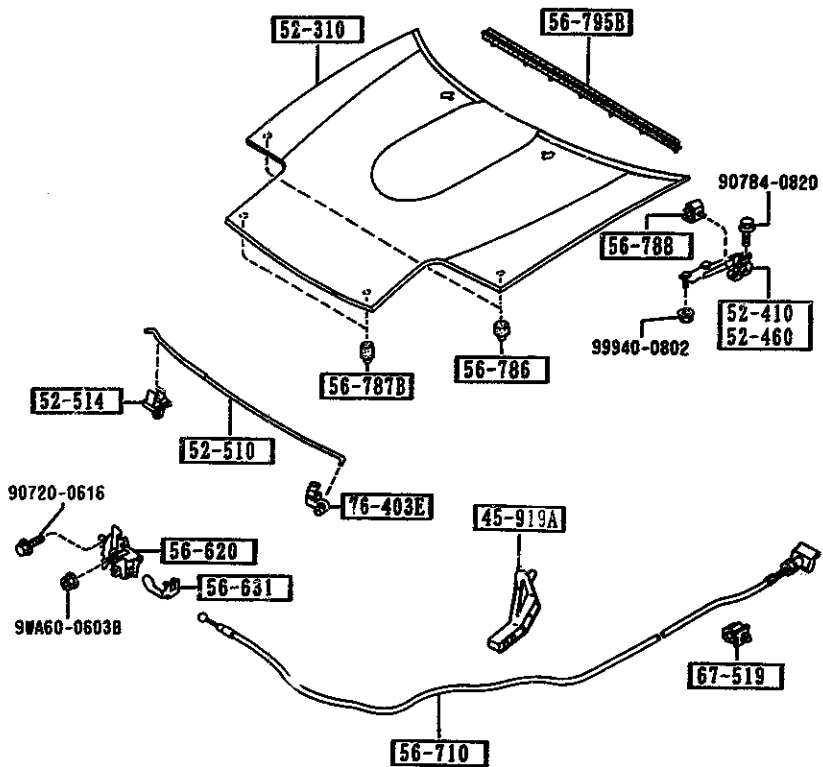

AUNA04

CAT. AUNA04-03

1995-04

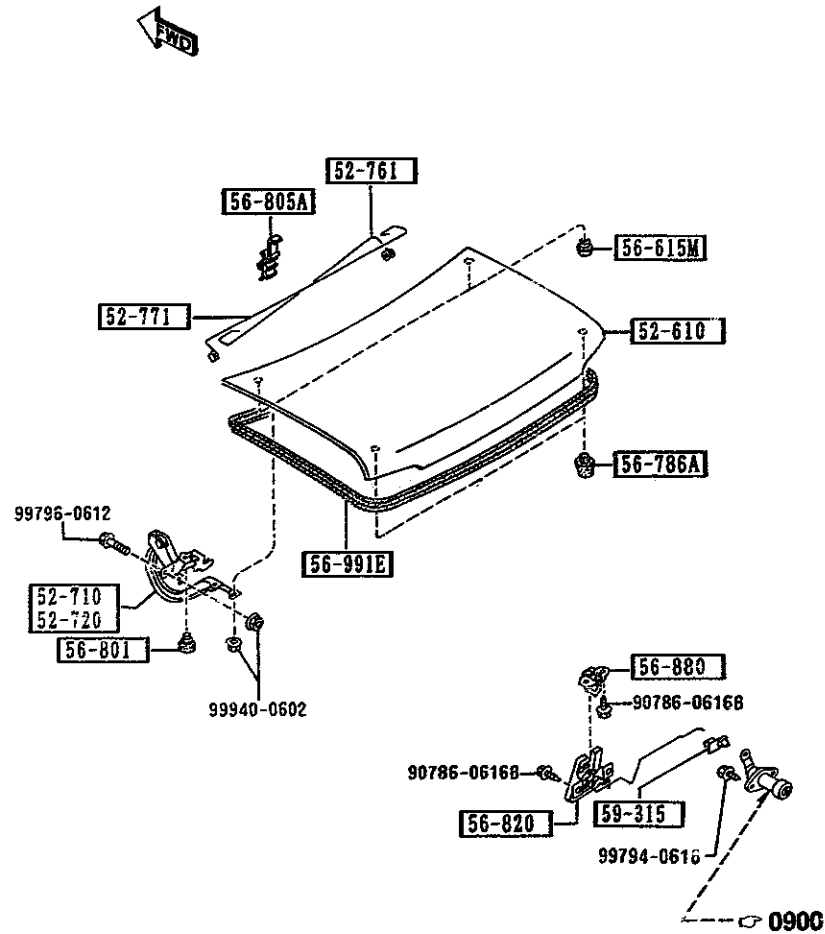

PART NO.	QTY	MODEL/RESTRICTION	MODEL/RESTRICTION	MODEL/RESTRICTION	FROM-TO
52-610		LID,TRUNK			
NAV1-52-610B	1				
52-710		HINGE(R),TRUNK LID			
NA01-52-710A	1				
52-720		HINGE(L),TRUNK LID			
NA01-52-720A	1				
52-761		SPRING(R),BALANCE			
NA01-52-791A	1				
52-771		SPRING(L),BALANCE			
NA01-52-792A	1				
56-615M		PLUG,DRAIN			
NA01-56-051	2				
56-786A		RUBBER,CUSHION			
B481-56-786	2				
56-801		CUSHION,LID HINGE			
NA01-56-802	2				
56-805A		HOLDER,BALANCE SPRING			
NA01-56-805	1				
56-820		LOCK,LID			
N007-56-820	1				
56-880		STRIKER,LID			
NA01-56-840	1				
56-991E		WEATHERSTRIP,LID			
NA01-56-951	1				
59-315		CLIP			
0030-59-315	1				

5310 -1 * FRONT PANELS

5310 FRONT PANELS

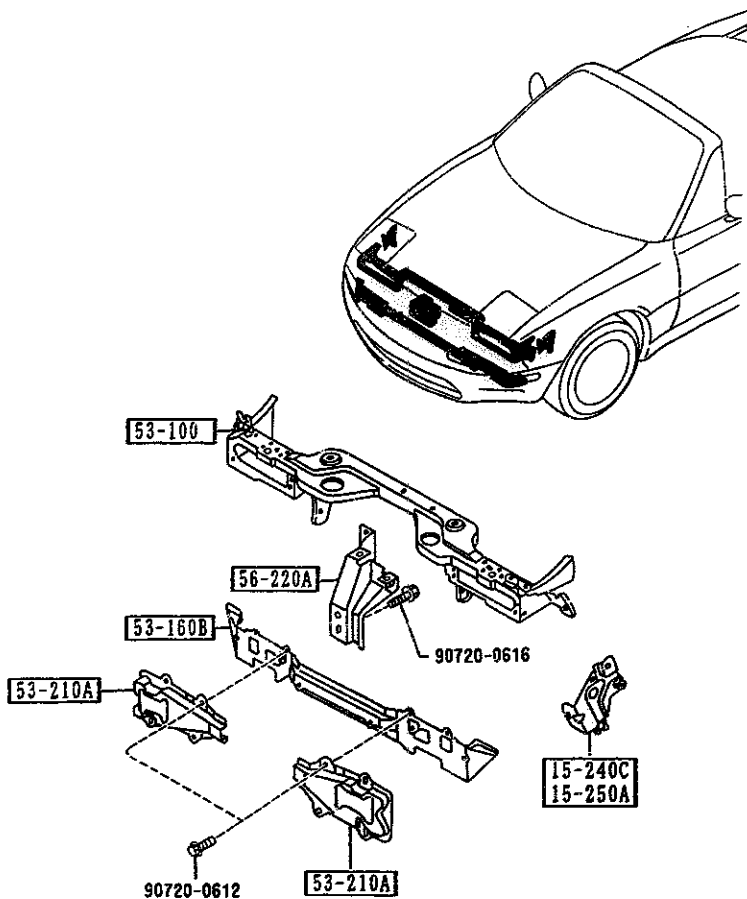

PART NO.	QTY	MODEL/RESTRICTION	MODEL/RESTRICTION	MODEL/RESTRICTION	FROM-TO
15-240C B61P-15-240A	1	BRACKET(R), RADIATOR			
15-250A B61P-15-250A	1	BRACKET(L), RADIATOR			
53-100 NA75-53-100	1	PANEL, RAD. SHROUD			
53-160B NA01-53-16XC	1	MEMBER, CROSS			
53-210A NA01-54-180	2	BRACKET, BUMPER			
56-220A NA01-56-221B	1	STAY, LOCK-BONNET			

AUNA04

CAT. AUNA04-03

1995-04

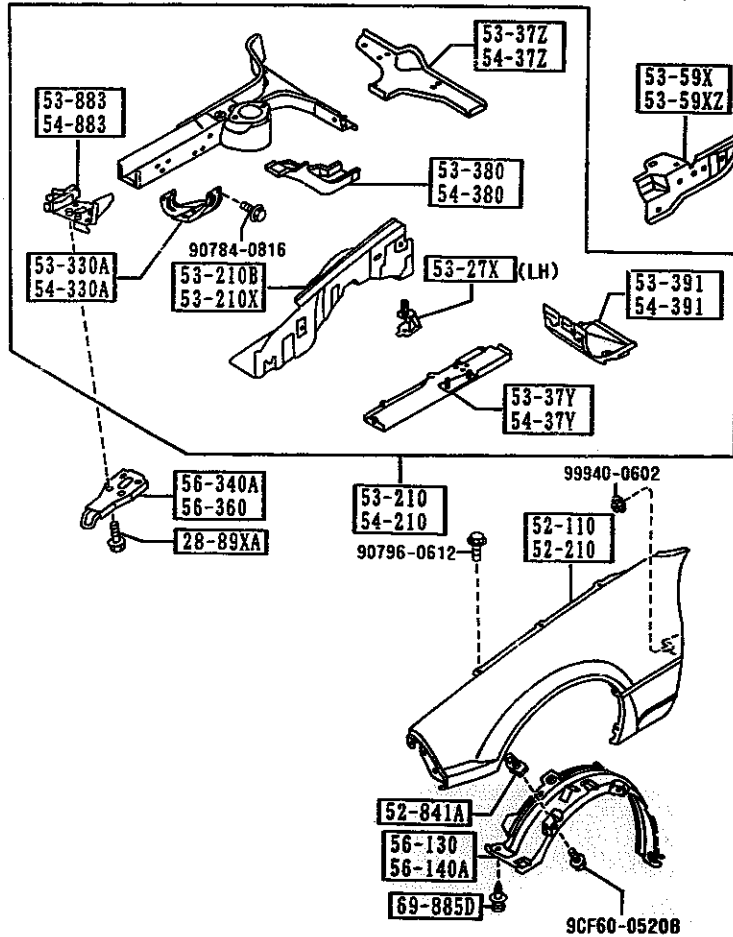
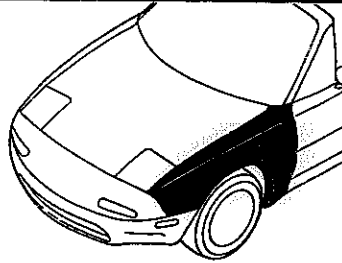

PART NO.	QTY	MODEL/RESTRICTION	MODEL/RESTRICTION	MODEL/RESTRICTION	FROM-TO
28-89XA 6J21-28-89X	6	BOLT,CROSS MEMBER			
52-110 NAV1-52-110	1	PANEL(R),FENDER-FRT.			
52-210 NAV1-52-210	1	PANEL(L),FENDER-FRT.			
52-841A LA01-56-135	10	NUT,CLIP			
53-210 NAV2-53-200	1	PANEL(R),WHEEL APRON			
53-210B NA01-53-210E	1	PANEL(R),WHEEL APRON			
53-210X NA01-54-210F	1	PANEL(L),WHEEL APRON			
53-27X NA01-54-36X	1	BRKT,AIR CLNR-WHL APRON			
53-330A NA01-53-330	1	BRACKET(R),STABILIZER			
53-37Y NA01-53-37Y	1	FRAME(UP.,R),FRONT-FRT			
53-37Z NA01-53-37ZA	1	FRAME(UP.,R),FRONT-REAR			
53-380 NA01-53-380	1	REINFORCEMENT(R)			
53-391 NA01-53-391	1	BOX(R),TORQUE			
53-59X NA01-53-591	1	REINF.(R),WHEEL APRON			

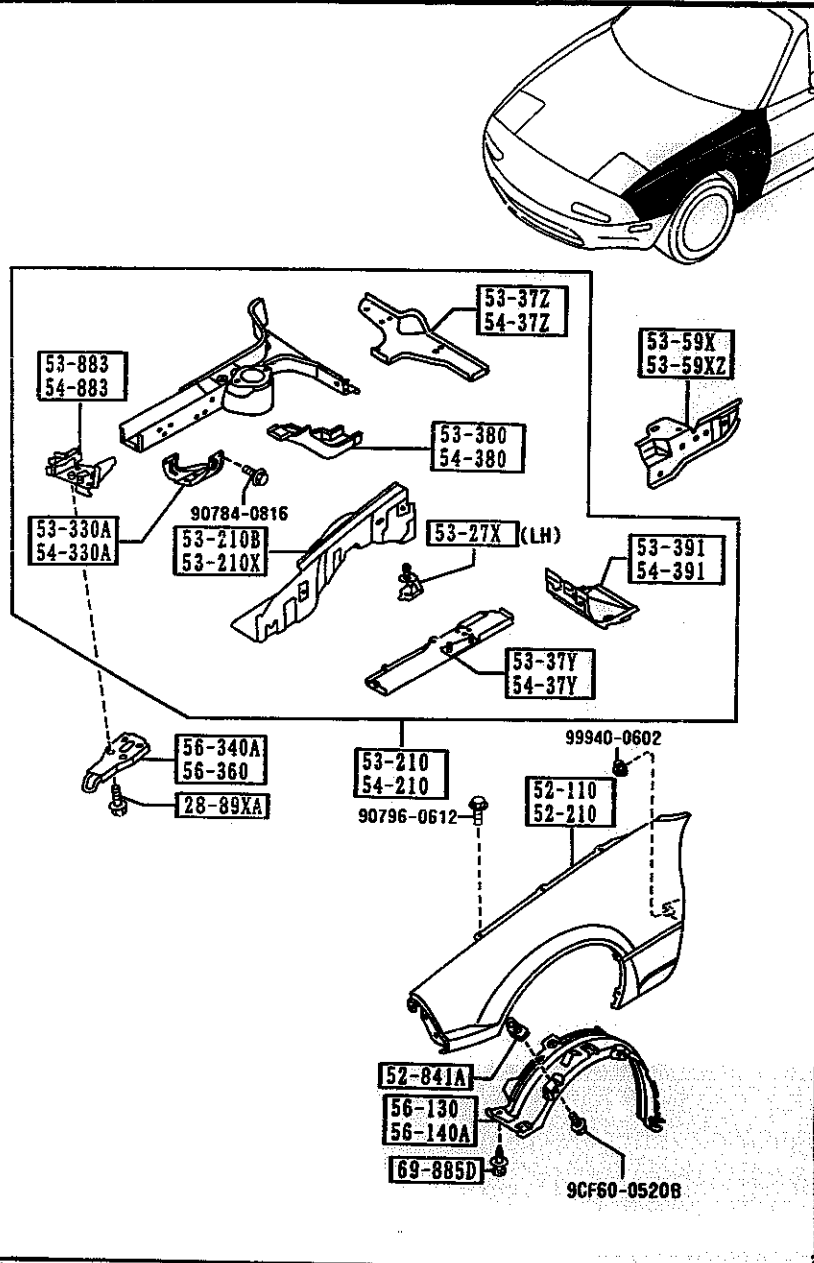

PART NO.	QTY	MODEL/RESTRICTION	MODEL/RESTRICTION	MODEL/RESTRICTION	FROM-TO
53-59XZ NA01-54-590	1	REINF.(L),WHEEL APRON			
53-883 NA01-53-32XB	1	REINF.(R),TIE DOWN HOOK			
54-210 NAV2-54-200	1	PANEL(L),WHEEL APRON			
54-330A NA01-54-330	1	BRACKET(L),STABILIZER			
54-37Y NA01-54-37Y	1	FRAME(UP.,L),FRONT-FRT			
54-37Z NA01-54-37ZA	1	FRAME(UP.L),FRONT-REAR			
54-380 NA01-54-380B	1	FRAME(L),FRONT-REAR			
54-391 NA01-54-391	1	BOX(L),TORQUE			
54-883 NA01-54-32XC	1	REINF.(L),TIE DOWN HOOK			
56-130 NA01-56-131A	1	GUARD(R),MUD			
56-140A NA01-56-141C	1	GUARD(L),MUD			
56-340A NA01-56-34XC	1	HOOK(R),TIE DOWN-FRONT			
56-360 NA01-56-34YC	1	HOOK(L),TIE DOWN-FRONT			
69-885D NA01-56-145	10	FASTENER			

ALNA04

CAT. AUNA04-03

1995-04

5330 -1 * DASH & COWL PANELS

5330 DASH & COWL PANELS

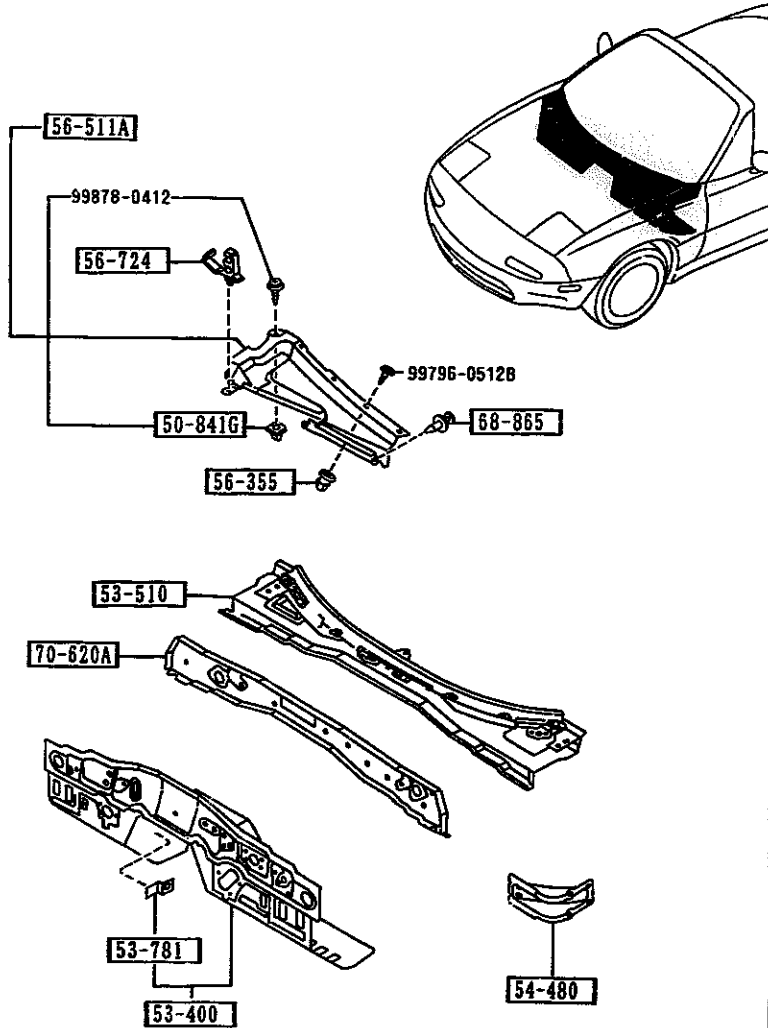

PART NO.	QTY	MODEL/RESTRICTION	MODEL/RESTRICTION	MODEL/RESTRICTION	FROM-TO
50-841G		GROMMET, SCREW			
F044-51-912	1				
53-400		PANEL, DASH-LOWER			
NA01-54-400G	1				
53-510		PANEL, DASH-UPPER			
NA75-53-510 AM(NA75-53-510A)	1				-4607
*NA75-53-510A	1				4607-
53-781		BRACKET, GRILLE-C			
0305-53-781A	1				
54-480		JUNCTION, DASH SIDE-S .SILL			
NA01-54-480	2				
56-355		GROMMET, SCREW-BAFFLE			
6211-56-355A	4				
56-511A		COVER, BAFFLE-COWL PA NEL			
NA01-56-35X	1				
56-724		CLIP 'B', WIRE-BONNET			
H260-56-724	1				
68-865		FASTENER			
8040-68-865A	2				
00	INT-	NA3 NA5 BLACK			
70-620A		PANEL, COWL-FRONT			
NA01-70-62YB	1				

4607 NA3~~NA5~~-519668

AUNA04

CAT. AUNA04-03

1995-04

5340 SIDE PANELS

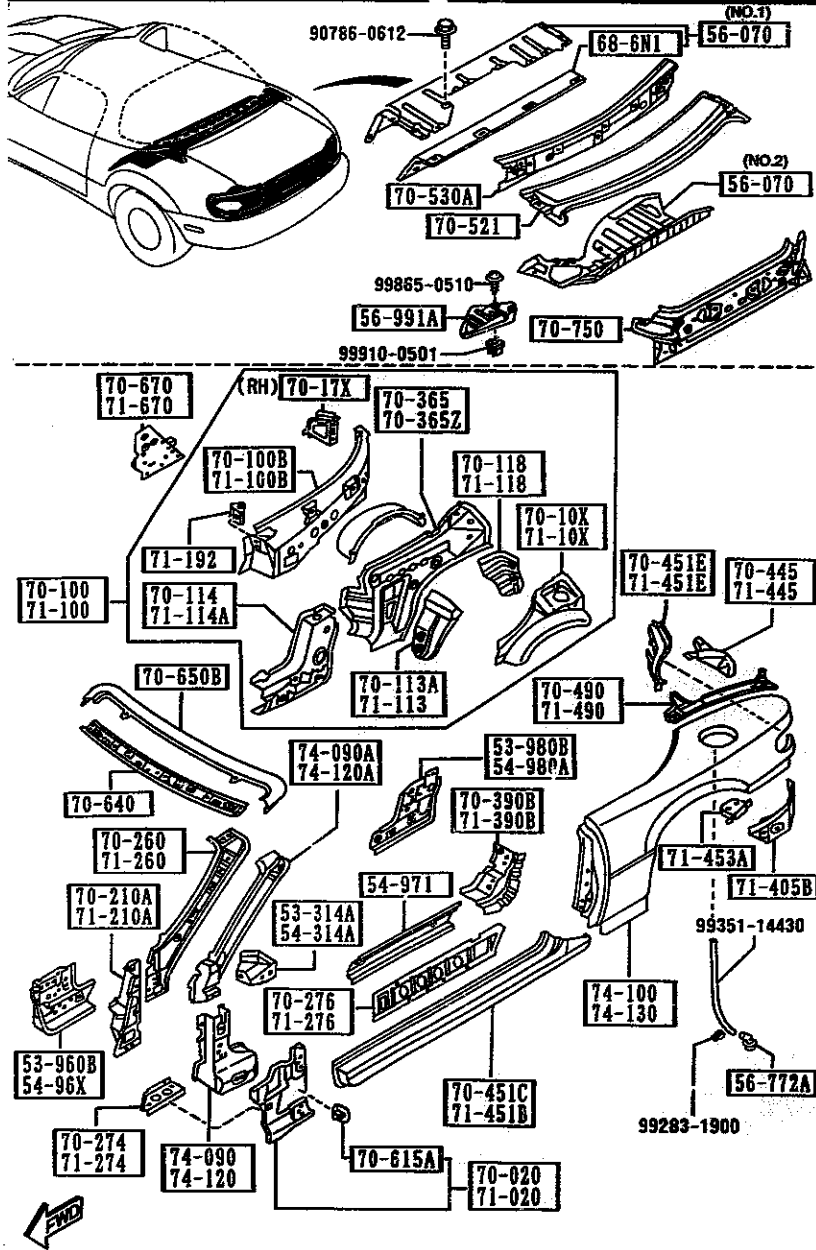

PART NO.	QTY	MODEL/RESTRICTION	MODEL/RESTRICTION	MODEL/RESTRICTION	FROM-TO
53-314A	1	BRACKET(R),INST.			
NA01-70-071A	1				
53-960B	1	SILL(FRT.R),SIDE-INNER			-3A01
NA75-53-960	1				3A01-
NA01-53-960C	1				
53-980B	1	SILL(RR.R),SIDE-INNER			-3A28
NA01-53-980B	1				3A28-
AN(NA01-53-980C)	1				
NA01-53-980C	1				
54-314A	1	BRACKET(L),INST.			
NA01-71-071A	1				
54-96X	1	SILL(FRT.L),SIDE-INNER			
NA01-54-96XB	1				
54-971	2	SILL(C),SIDE-INNER			-3A01
NA75-54-971	2				3A01-
NA01-54-971A	2				
54-980A	1	SILL(RR.L),SIDE-INNER			-3A28
NA01-54-980B	1				3A28-
AN(NA01-54-980C)	1				
NA01-54-980C	1				
56-070	1	PANEL,BULK HEAD			
NA01-56-39YA	1	(ILLUST. NO.1)			
NA01-70-51Y	1	(ILLUST. NO.2)			
56-772A	1	PIPE,DRAIN-RR FENDER			
NA01-56-772	1				
56-991A	1	COVER,SERVICE HOLE			
NA01-56-971	1				
68-6N1	1	INSULATOR,BALK HEAD PANEL			
NA01-68-6N1	1				
3A01 NA3888-505179					
3A28 NA3888-505745					

AUNA04

CAT. AUNA04-03

1995-04

5340 SIDE PANELS

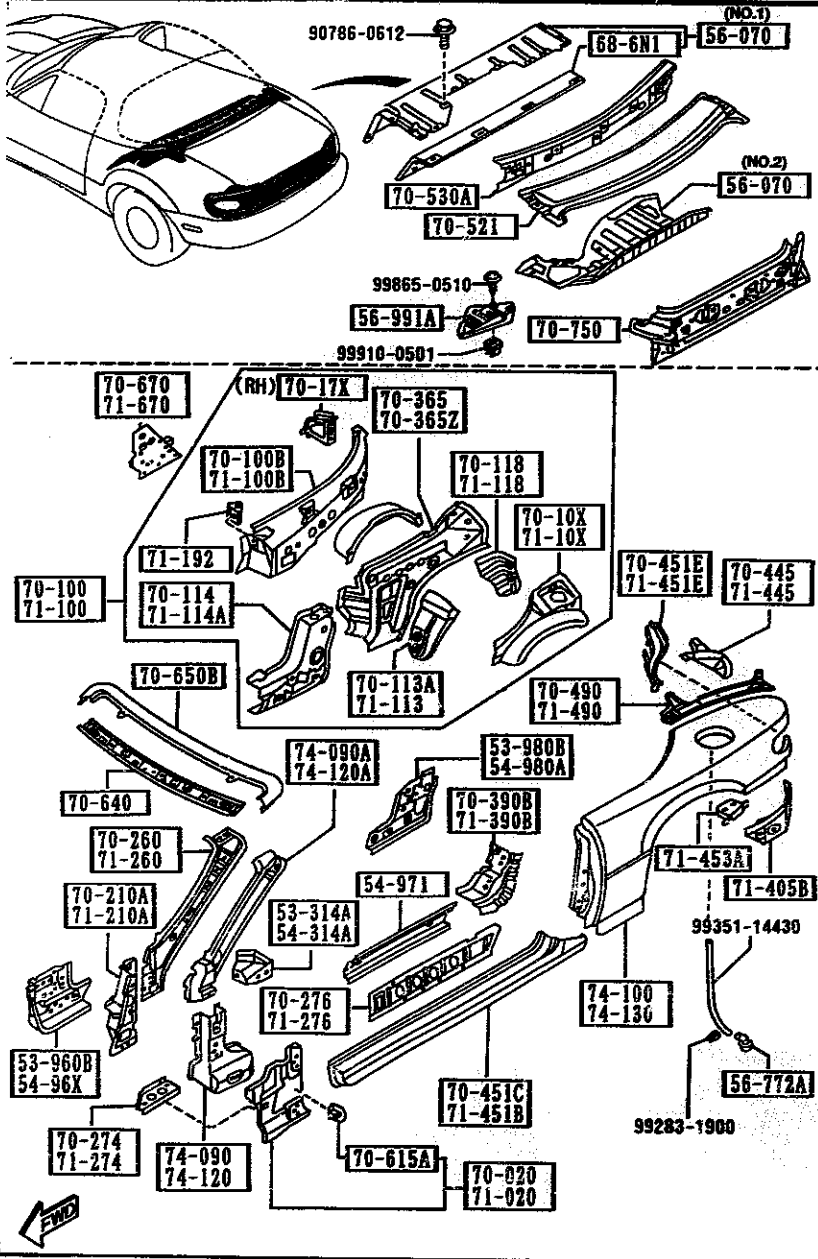

PART NO.	QTY	MODEL/RESTRICTION	MODEL/RESTRICTION	KODEL/RESTRICTION	FROM-TO
70-390B	1	REINF.(R),STRIKER			
NA01-70-460					
70-445	1	GUSSET(R),REAR FENDE R-RR			
NA01-70-445					
70-451C	1	SILL(R),SIDE OUT.			
NA01-70-270B					
70-453E	1	HOUSING(R),LAMP-RR FEMDER			
NA01-70-J30					
70-490	1	RAIL(R),RAIN-REAR			
NA01-70-440A					
70-521	1	PANEL,REAR DECK			
NA01-70-521A					
70-530A	1	MEMBER,REAR DECK			
NA01-70-530A					
70-615A	2	BRACKET,FENDER			
B092-70-070A					
70-640	1	HEADER,FRONT			
NA01-70-640					
70-650B	1	HEADER,FRONT-UPPER			
NA01-70-650					
70-670	1	PLATE(R),CLOSING-QTR PANEL			
NA01-70-670					
70-750	1	PANEL,REAR END			
NA01-70-750G					
71-020	1	PANEL(L),COWL SIDE			
NA01-71-020B					
71-10X	1	PANEL(L),QUARTER			
NA01-71-11XB					

CAT. AUNA04-03

1995-04

5340 SIDE PANELS

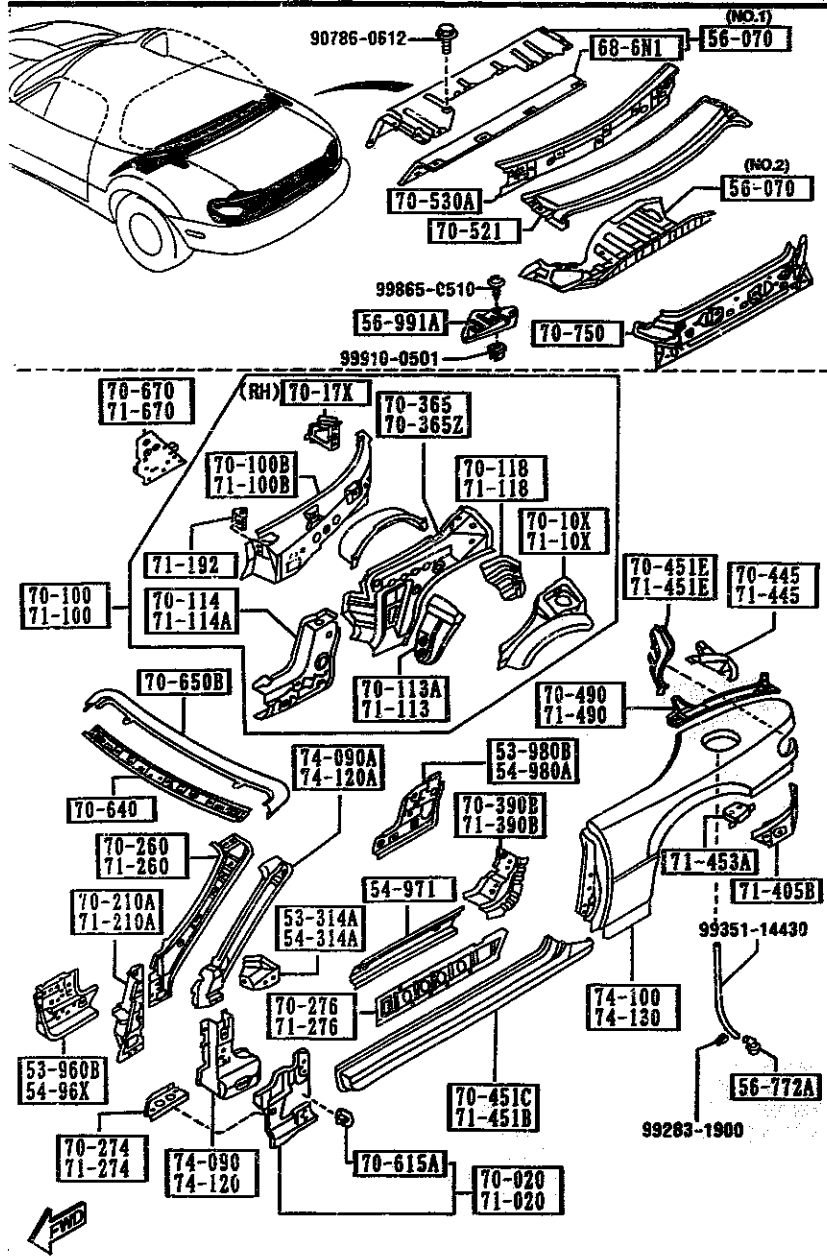

PART NO.	QTY	MODEL/RESTRICTION	MODEL/RESTRICTION	MODEL/RESTRICTION	FROM-TO
71-100		PANEL(L), QUARTER			
NA75-71-100	1				
71-100B		PANEL(L), INSIDE			
NA01-71-19XB	1				
71-113		PLATE(L), SEAL			
NA01-71-11Z	1				
71-114A		JUNCTION(L), CORNER-Q /PANE			
NA01-71-12XA	1				
71-118		PROTECTOR(L), SPLASH			
NA01-71-15XA	1				
71-192		BRKT, CAP-QUARTER PAN EL			
NA01-71-192	2				
71-210A		PILLAR(L), HINGE			
NA01-71-230	1				
71-260		PILLAR(L), FRT. - INNER			
NA01-71-240B	1				
71-274		GUSSET(L), SIDE SILL OUTER			
NA01-71-274	1				
71-276		REINF.(L), SIDE SILL			
NA01-71-275	1				
71-390B		REINF.(L), STRIKER			
NA01-71-460	1				
71-405B		PANEL(L), RR FENDER-L OMER			
NA01-71-421	1				
71-445		GUSSET(L), REAR FENDE R-RR			
NA01-71-445	1				
71-451B		SILL(L), SIDE OUT.			
NA01-71-270B	1				

AJNA04

CAT. AJNA04-03

1995-04

5340 SIDE PANELS

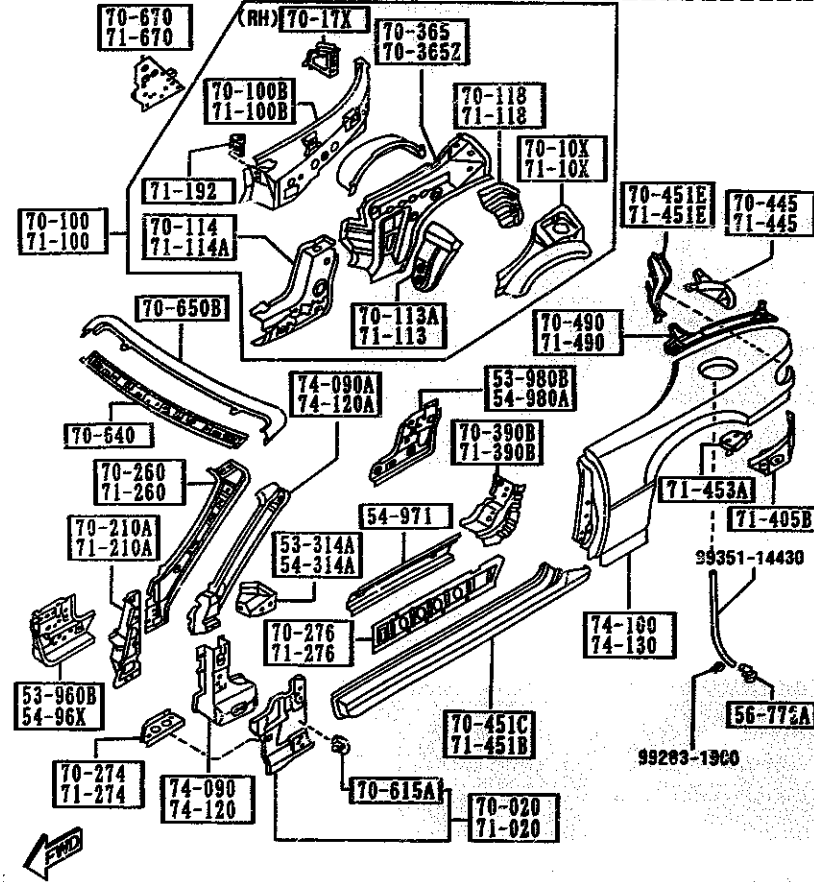
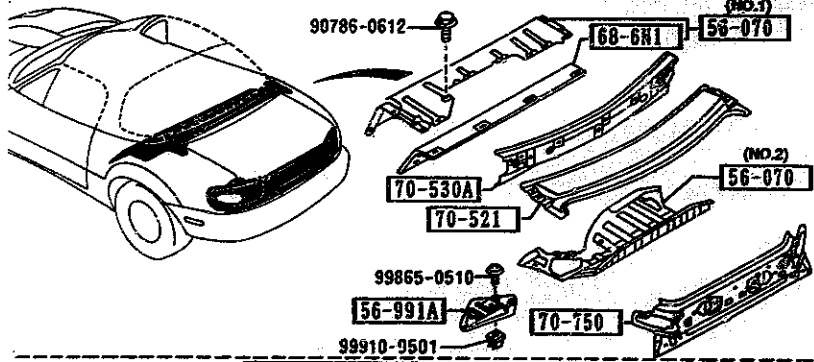

AUMA04

PART NO.	QTY	MODEL/RESTRICTION	MODEL/RESTRICTION	MODEL/RESTRICTION	FROM-TO
71-451E	1	HOUSING(L),LAMP-RR F			
NA01-71-J30		ENDER			
71-455A	1	BRKT(L),TRK. BOARD-FE			
NA01-71-453		NDER			
71-490	1	RAIL(L),RAIN-REAR			
NA01-71-440A					
71-670	1	PLATE(L),CLOSING-QTR			
NA01-71-670B		PANEL			
74-090	1	PILLAR(R),HINGE-OUT.			
NA01-70-280B					
74-090A	1	PILLAR(R),FRONT-OUT.			
NA01-70-210					
74-100	1	PANEL(R),FENDER-REAR			
NA01-70-400B					
74-120	1	PILLAR(L),HINGE-OUT.			
NA01-71-280B					
74-120A	1	PILLAR(L),FRONT-OUT.			
NA01-71-210					
74-130	1	PANEL(L),FENDER-REAR			
NA01-71-400B					

CAT. AUMA04-03

1995-04

5370 FLOOR PANELS

5370 -1 FLOOR PANELS

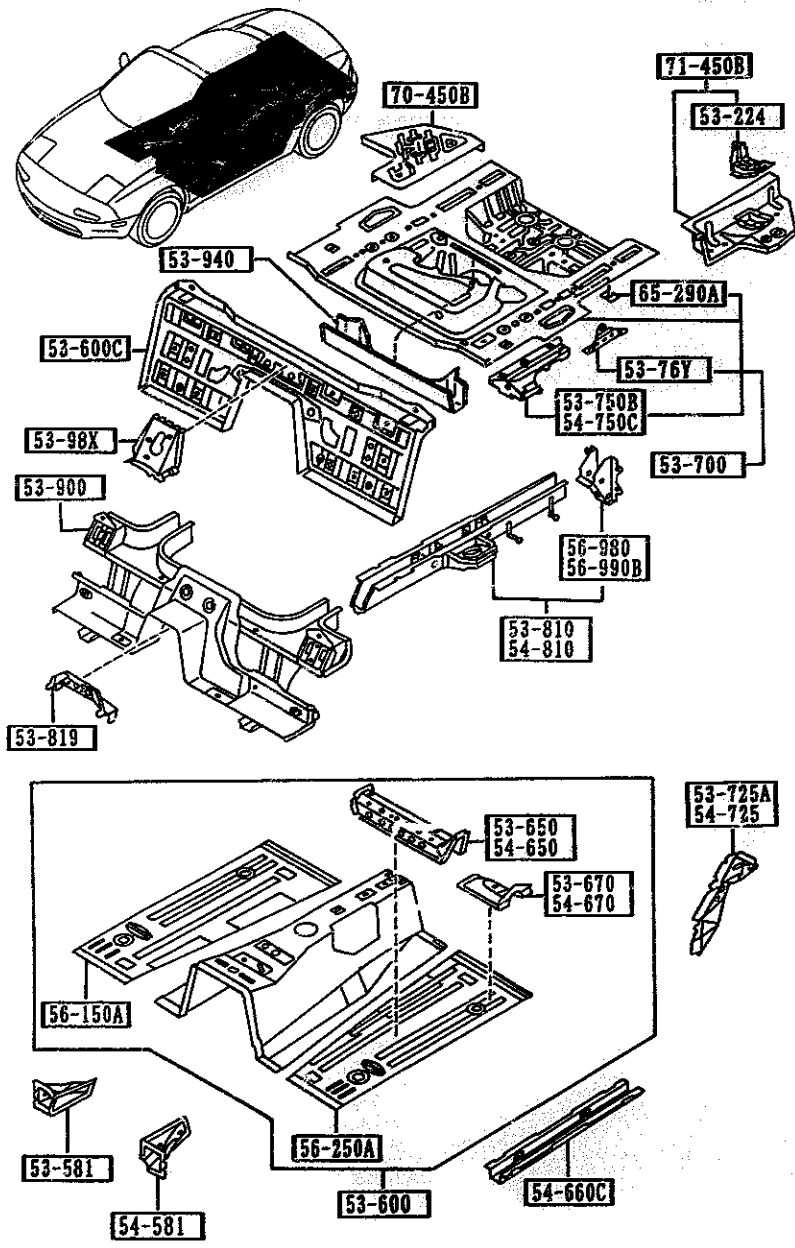

PART NO.	QTY	MODEL/RESTRICTION	MODEL/RESTRICTION	MODEL/RESTRICTION	FROM-TO
53-224	1	BRACKET, JACK			
B455-53-750C					
53-581	1	JUNCTION(R), FRT. FLOOR			
MA01-53-482					
53-600	1	PAN, FLOOR-FRONT			
MA01-53-600A					
53-600C	1	PAN, FLOOR-CENTER			
MA75-53-720					
53-650	1	MEMBER NO. 2(R), CROSS-FLOOR			
MA01-53-650					
53-670	1	BRKT(R), SEAT-F. FLOOR PAN			
MA01-53-670					
53-710	1	PAN, FLOOR-REAR			
MA01-53-710B					
53-725A	1	GUSSET NO. 3(R), C. FLOOR PAN			
MA01-53-725A					
53-750B	1	PLATE(R), SIDE-REAR FLOOR			
MA01-53-750					
53-76Y	2	PLATE, NUT-TRUNK FLOOR PAN			
MA01-53-760					
53-810	1	FRAME(R), REAR SIDE			
MA01-53-810F					
53-819	1	BRACKET, PARKING CABL E-FLOOR			
MA01-53-819					
53-900	1	MEMBER NO. 3, CROSS			
MA75-53-900					
53-940	1	MEMBER NO. 4, CROSS			
MA01-53-931					

AJMA04

CAT. AJMA04-03

1995-04

5370 FLOOR PANELS

5370 -2 FLOOR PANELS

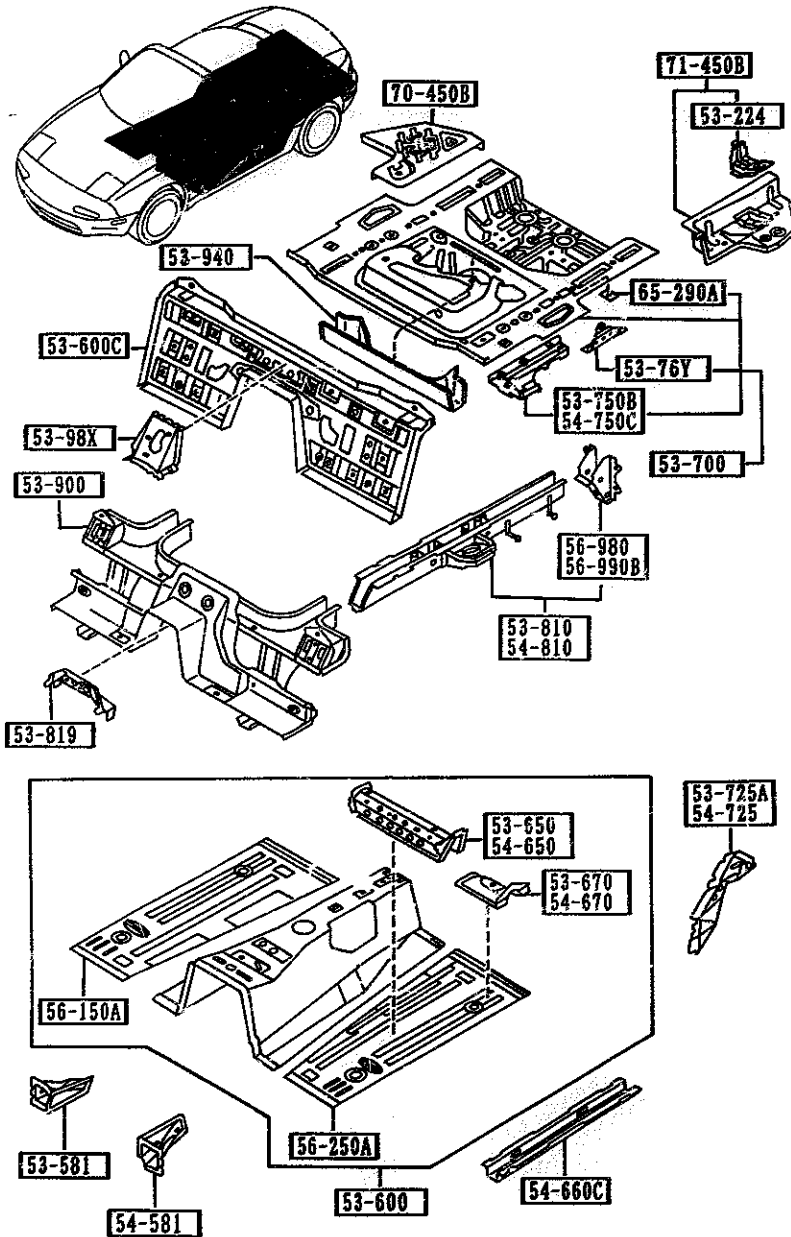

PART NO.	QTY	MODEL/RESTRICTION	MODEL/RESTRICTION	MODEL/RESTRICTION	FROY-TU
53-98X NA01-53-880A	1	GUSSET,FRONT FLOOR P AP			
54-581 NA01-54-482	1	JUNCTION(L),FRT. FLO OR			
54-650 NA01-54-650	1	MEMBER NO.2(L),CROSS -FLOOR			
54-660C NA01-54-660B	2	FRAME,FRONT-FRT FLOO R PAN			
54-670 NA01-54-670	1	BRKT(L),SEAT-F.FLOOR PAN			
54-725 NA01-54-725A	1	GUSSET NO.3(L),C.FLO OR PAN			
54-750C NA01-54-750	1	PLATE(L),SIDE-REAR F LOOR			
54-810 NA01-54-810F	1	FRAME(L),REAR SIDE			
56-150A NA01-53-602	1	PAN(R),FLOOR			
56-250A NA01-54-610	1	PAN(L),FLOOR			
56-980 NA01-53-830C	1	BRKT(R),BUMPER-RR SK IRT			
56-990B NA01-54-830C	1	BRKT(L),BUMPER-RR SK IRT			
65-290A 1353-65-190	1	BRACKET			
70-450B NA01-53-740C	1	PANEL(R),FLOOR SIDE			

AUNA04

CAT. AUNA04-03

1995-04

5370 FLOOR PANELS

5370 -3 * FLOOR PANELS

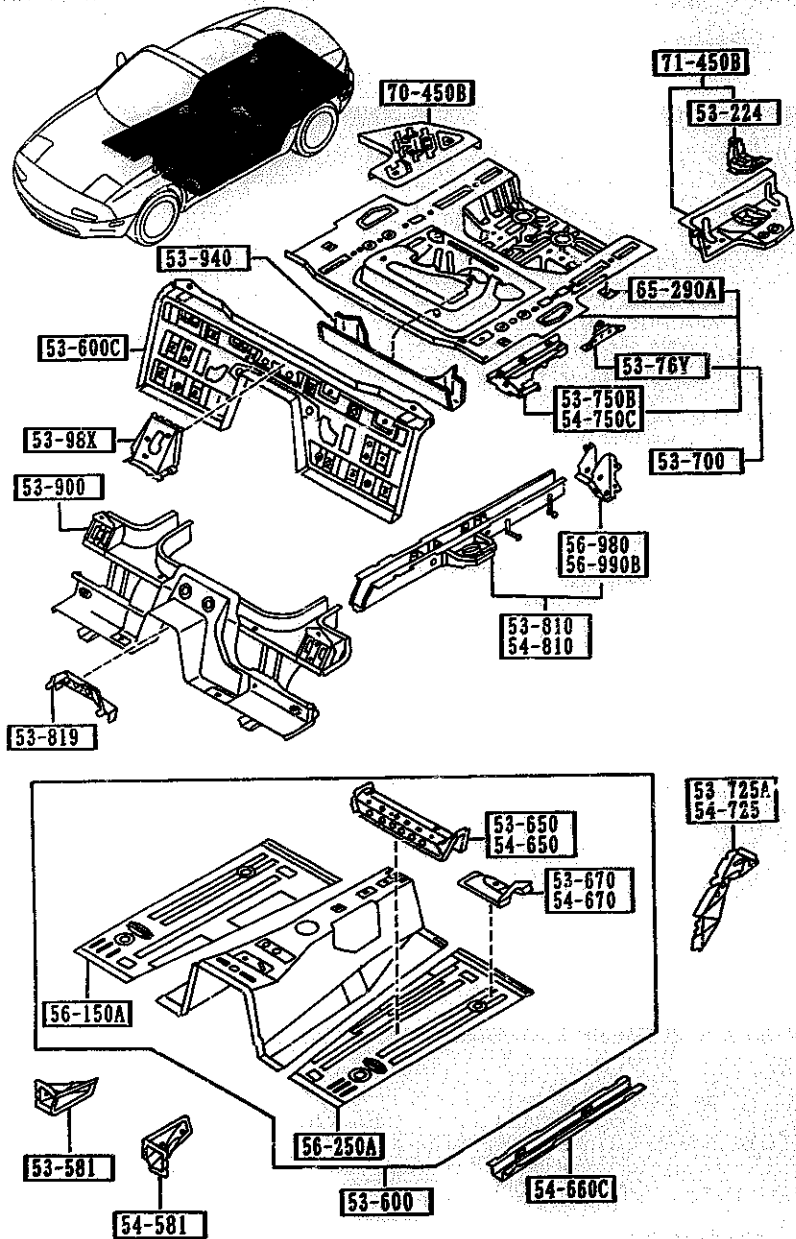

PART NO.	QTY	MODEL/RESTRICTION	MODEL/RESTRICTION	MODEL/RESTRICTION	FROM-TO
71-450B					
NA01-54-740A	1	PANEL(L), FLOOR SIDE			

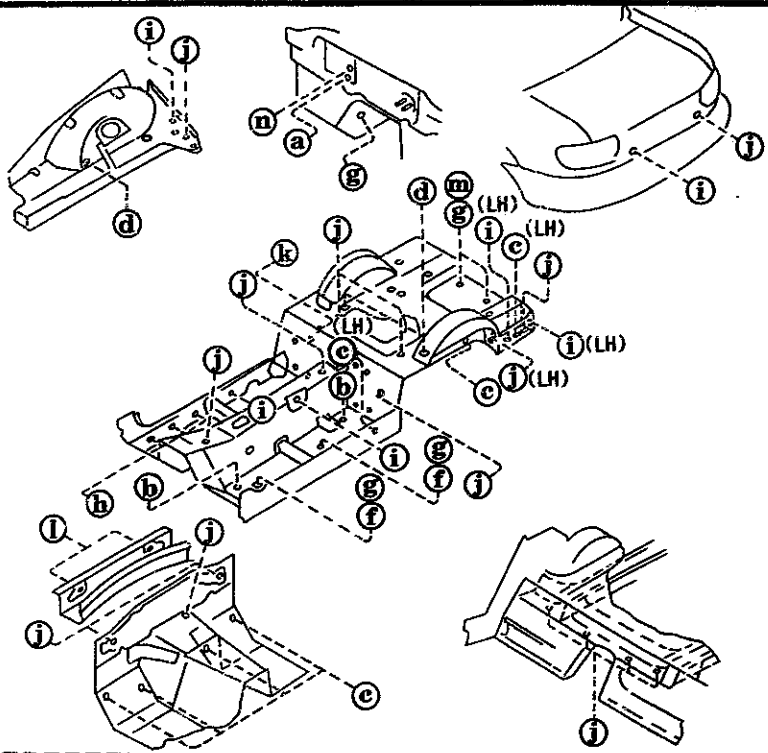

- | | | | |
|---|---------|--|--------------------|
| a | 53-1349 | | (HOLE ϕ 28) |
| b | 56-051 | | |
| c | 56-052 | | (HOLE ϕ 20.5) |
| d | 56-052 | | (HOLE ϕ 20.5) |
| f | 56-061A | | (HOLE ϕ 85) |
| g | 56-241 | | (HOLE ϕ 20) |
| h | 56-241B | | (HOLE ϕ 29) |
| i | 56-241J | | |
| j | 56-242 | | (HOLE ϕ 22) |
| k | 56-615F | | (HOLE ϕ 40) |
| l | 56-615M | | (HOLE ϕ 15) |
| m | 56-971 | | (HOLE ϕ 100) |
| n | 61-031 | | (HOLE ϕ 38) |

PART NO.	QTY	MODEL/RESTRICTION	MODEL/RESTRICTION	MODEL/RESTRICTION	FROM-TO
53-1349	1	RUBBER, DUST SEAL			
0187-53-134					
56-051	4	COVER, HOLE			
1011-56-051					
56-052	8	PLUG, DRAIN			
8092-56-052					
FB01-56-056	4	D=12MM (ILLUST. NO. 1)			
56-061A	4	COVER, HOLE			
8545-56-052					
56-241	7	PLUG, DRAIN			
0118-56-241					
56-241B	6	PLUG			
8001-56-051					
56-241J	9	PLUG, DRAIN			
8477-56-241					
56-242	19	PLUG, DRAIN			
0118-56-242B					
56-615F	2	PLUG, DRAIN			
0208-56-615					
56-615M	2	PLUG, DRAIN			
NA01-56-051					
56-971	2	COVER, HOLE			
8545-56-053					
61-031	1	PLUG, HOLE			
1708-61-031					

ALHA04

CAT. AUHA04-03

1995-04

5390 FLOOR ATTACHMENTS

5390 -2 * FLOOR ATTACHMENTS

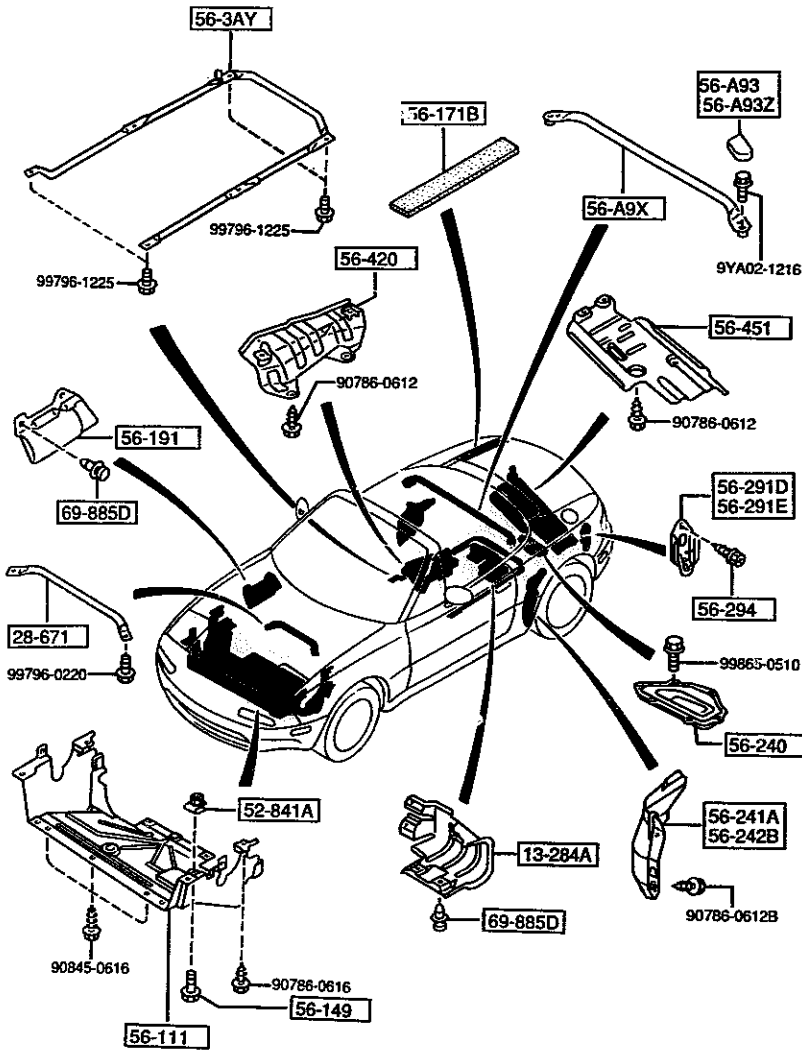

PART NO.	QTY	MODEL/RESTRICTION	MODEL/RESTRICTION	MODEL/RESTRICTION	FROM-TO
56-291E NA01-56-290C	1	HOOK(L),TIE DOWN			
56-294 NA01-56-294	4	SCREW,TIE DOWN HOOK			
56-3AY NA75-56-3AY	1	REINF.(L),FLOOR			
56-420 NA75-56-411	1	INSULATOR,FRONT			
56-451 NA01-56-451	1	INSULATOR			
69-885D NA01-56-145	7	FASTENER			

AUNA04

CAT. AUNA04-03

1995-04

5500 DASHBOARD EQUIPMENTS

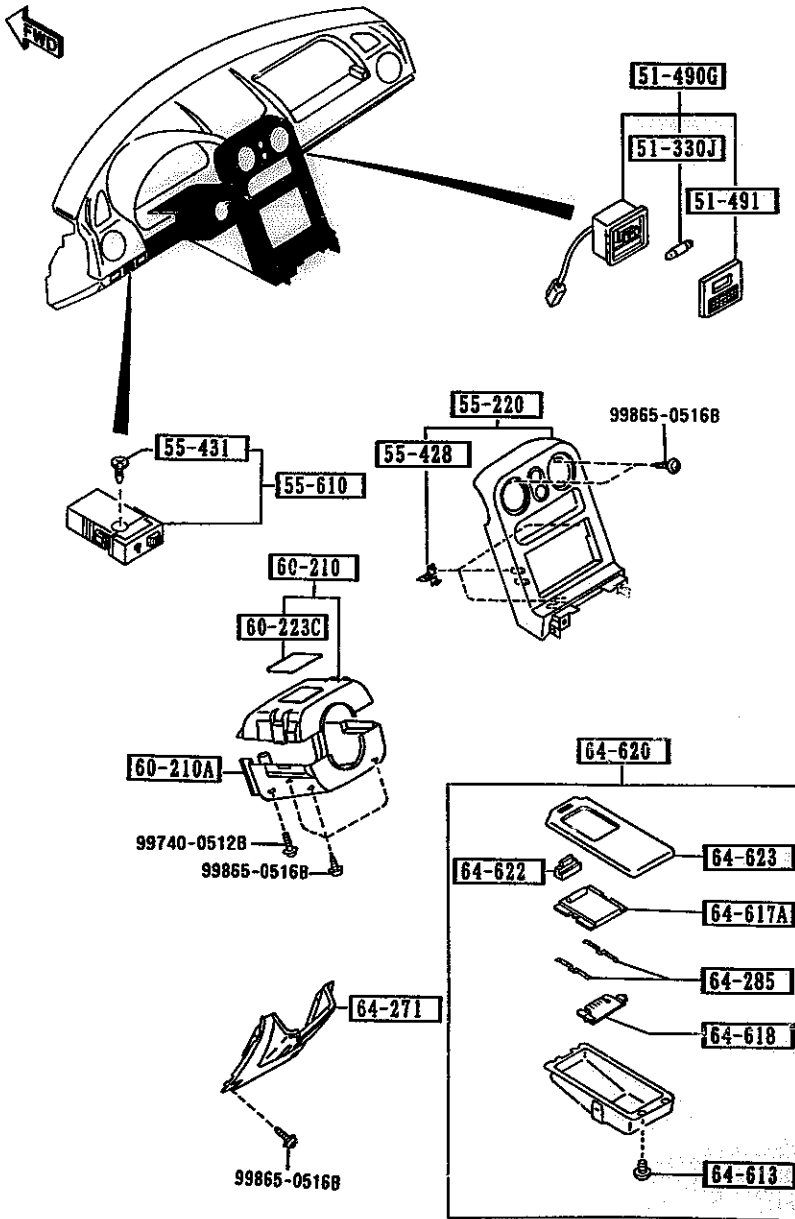

5500 -1 DASHBOARD EQUIPMENTS

PART NO.	QTY	MODEL/RESTRICTION	MODEL/RESTRICTION	MODEL/RESTRICTION	FROM-TO
51-330J		BULB			
99701-5050	1	12V 5W			
51-490G		LAMP, PERSONAL			
NA01-51-490B	1				
00	INT-	NA3 NA5 NA4 NA6 BLACK			
51-491		LENS, PERSONAL LAMP			
H197-51-491A	1				
00	INT-	NA3 NA5 BLACK			
55-220		PANEL, CENTER			
NA75-55-210A	1				
00	INT-	NA3 NA4 NA5 NA6 BLACK			
55-428		SPRING, METER HOOD			
GJ21-55-428	3				
55-431		BULB, RESISTOR			
BR70-55-431	1				
55-610		RESISTOR, PANEL LIGHT			
BR70-55-490	1				
60-210		COVER, COLUMN-UPPER			
NA01-60-220	1				
00	INT-	NA3 NA5 NA4 NA6 BLACK			
60-210A		COVER, COLUMN-LOWER			
NA01-60-230A	1				
00	INT-	NA3 NA5 NA4 NA6 BLACK			
60-223C		CAP, COLUMN COVER			
NA01-60-223	1				
00	INT-	NA3 NA5 NA4 NA6 BLACK			

AUNA04

CAT: AUNA04-03

1995-04

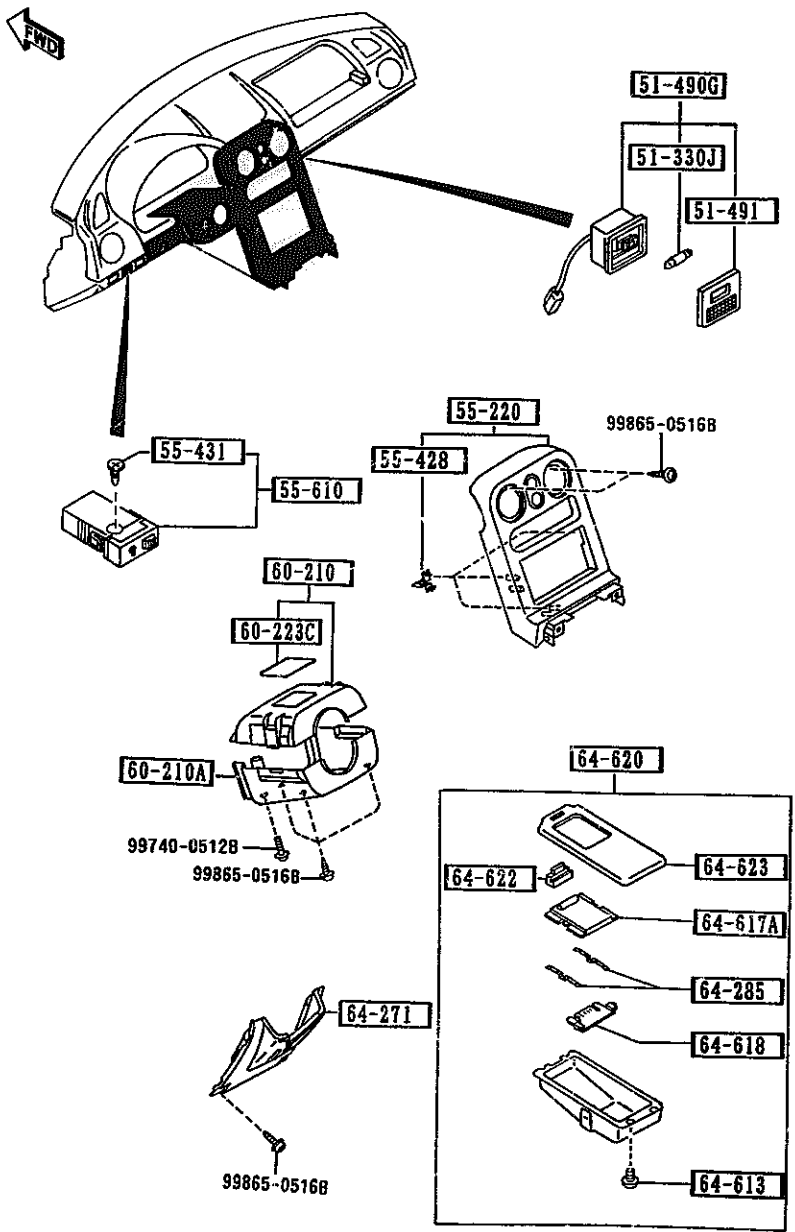

PART NO.	QTY	MODEL/RESTRICTION	MODEL/RESTRICTION	MODEL/RESTRICTION	FROM-TO
64-271		PANEL,CENTER-LOWER			
NA75-64-270A	1				-3923
00	INT-	NA3 BLACK			
88	INT-	NA4 NA5 TAN			
NA75-64-270B	1				3923-
00	INT-	NA3 BLACK			
88	INT-	NA4 NA5 TAN			
64-285		SPRING,ASHTRAY			
NA01-64-612	2				
64-613		SCREW,ASHTRAY			
NA01-64-613	4				
64-617A		LID,ASHTRAY			
NA01-64-617	1				
00	INT-	NA3 NA5 NA4 NA6 BLACK			
64-618		PLATE,ASHTRAY			
NA01-64-618	1				
64-620		TRAY,ASH			
NA01-64-610B	1				
00	INT-	NA3 NA5 NA4 NA6 BLACK			
64-622		LIGHT,PLATE-ASHTRAY			
NA01-64-622	1				
64-623		CASE'OUT',ASHTRAY			
NA01-64-623	1				
00	INT-	NA3 NA5 NA4 NA6 BLACK			
3923 NA3***-504494					

AUNA04

CAT. AUNA04-03

1995-04

5520 METER HOOD

5520 -1 * METER HOOD

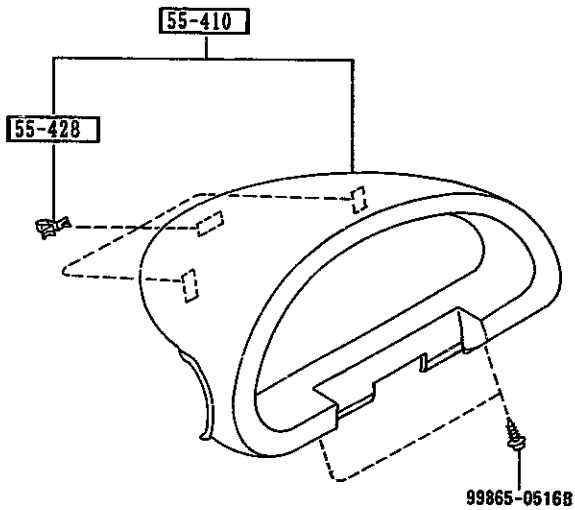

PART NO.	QTY	MODEL/RESTRICTION	MODEL/RESTRICTION	MODEL/RESTRICTION	FROM-TO
55-410		HOOD, METER			
NA75-55-420B	1	BASE, PKG-A, PKG-B, PKG-R, (INSTRUMENT PANEL-BLACK)			
00	INT-	NA3 NA4 NA5 BLACK			
NA75-55-420B	1	PKG-C, (INSTRUMENT PANEL-TAN)			
00	INT-	NA4 NA5 BLACK			
55-428		SPRING, METER HOOD			
6J21-55-428	3				

AUNA04

CAT. AUNA04-03

1995-04

5530 SPEEDOMETER CABLE

5530 -1 * SPEEDOMETER CABLE

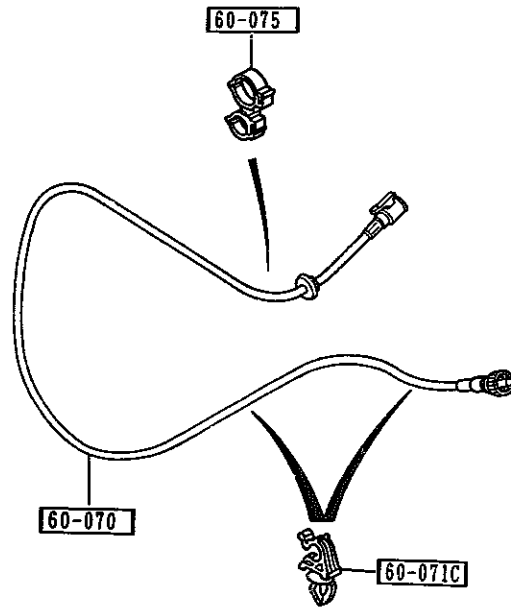

PART NO.	QTY	MODEL/RESTRICTION	MODEL/RESTRICTION	MODEL/RESTRICTION	FROM-TO
60-070		CABLE, SPEEDOMETER			
NA01-60-070B	1	(MT)			
NA03-60-070A	1	(AT)			
60-071C		CLIP			
NA03-60-071	2				
60-075		CLIP 'A', SPEEDOMETER CABLE			
NA01-60-075	1				



AUNA04

CAT. AUNA04-03

1995-04

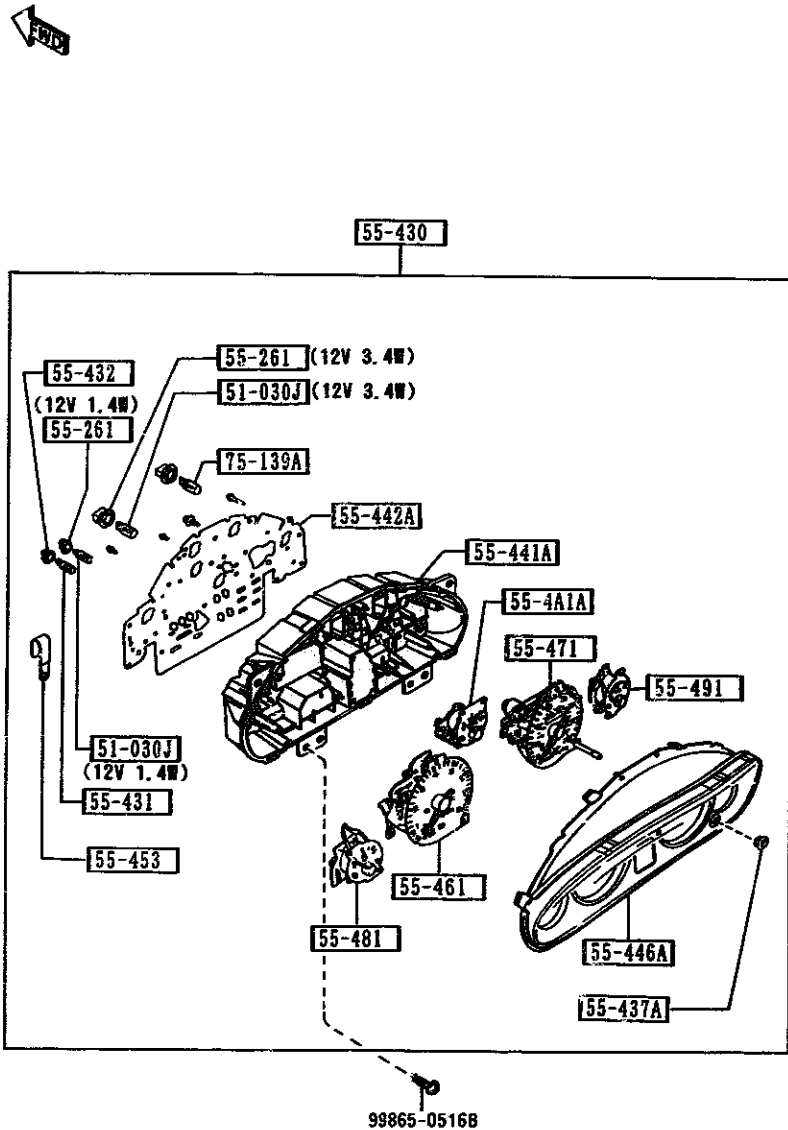

PART NO.	QTY	MODEL/RESTRICTION	MODEL/RESTRICTION	MODEL/RESTRICTION	FROM-TO
51-030J		BULB			
3625-75-139	8	12V 1.4W, FOR WARNING			
99701-6050	3	12V 3.4W			
55-261		SOCKET			
1316-55-261	3	12V 3.4W			
8548-55-261	8	12V 1.4W ELACK			
55-4A1A		METER, OIL PRESSURE			
NA01-55-4A1	1				
55-430		METER SET			
NA75-55-430A	1				
55-431		BULB, RESISTOR			
NA01-55-431	1				
55-432		SOCKET, METER SET			
NA01-55-432	1				
55-437A		GROMMET, KNOB-METER SET			
NA01-55-437	1				
55-441A		CASE, METER			
NA01-55-441C	1				
55-442A		PLATE, PRINT			
NA75-55-442	1				
55-446A		PLATE, WINDOW			
NA01-55-446B	1				
55-453		CLAMP			
NA007-55-467	1				
55-461		TACHOMETER			
NA75-55-461	1				

5540 METER COMPONENTS

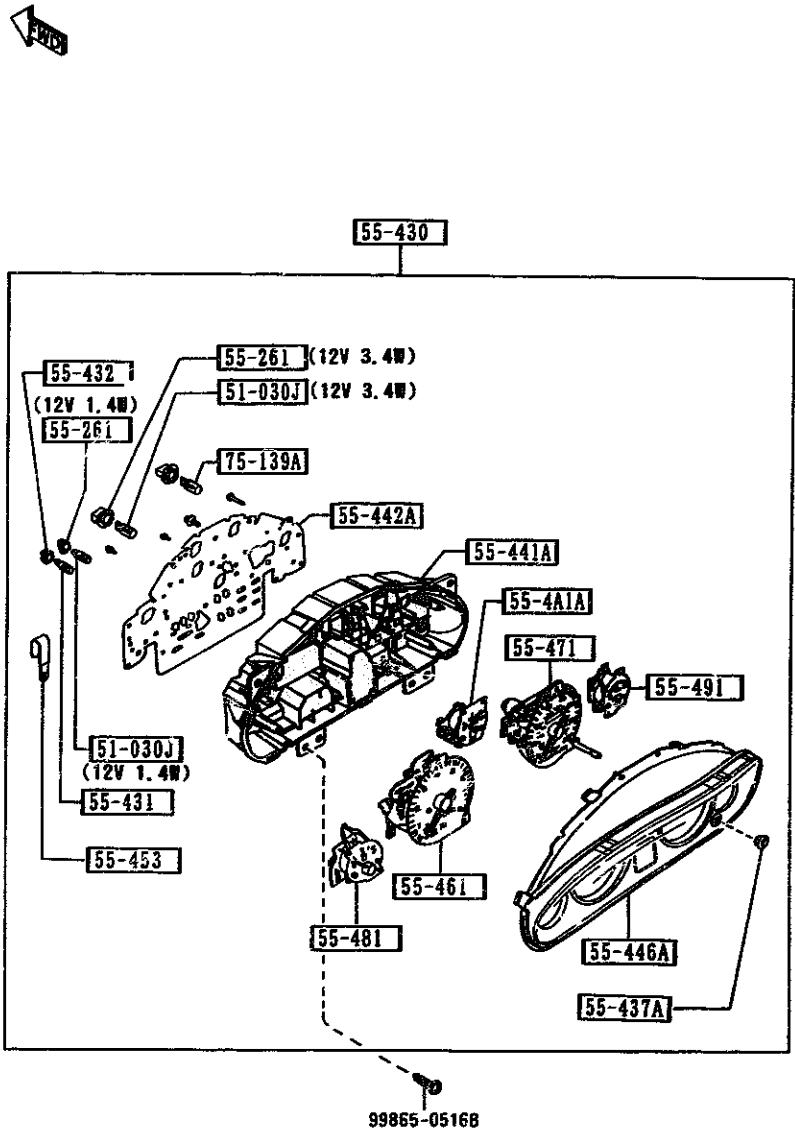

5540 -2 * METER COMPONENTS

PART NO.	QTY	MODEL/RESTRICTION	MODEL/RESTRICTION	MODEL/RESTRICTION	FROM-TO
55-471		SPEEDOMETER			
NA01-55-471B	1				
55-481		METER, FUEL			
NA01-55-481	1				
55-491		METER, TEMP			
NA75-55-491	1				
75-139A		BULB			
B491-55-431	4				

5560 DASHBOARD & RELATED PARTS

5560 -1 DASHBOARD & RELATED PARTS

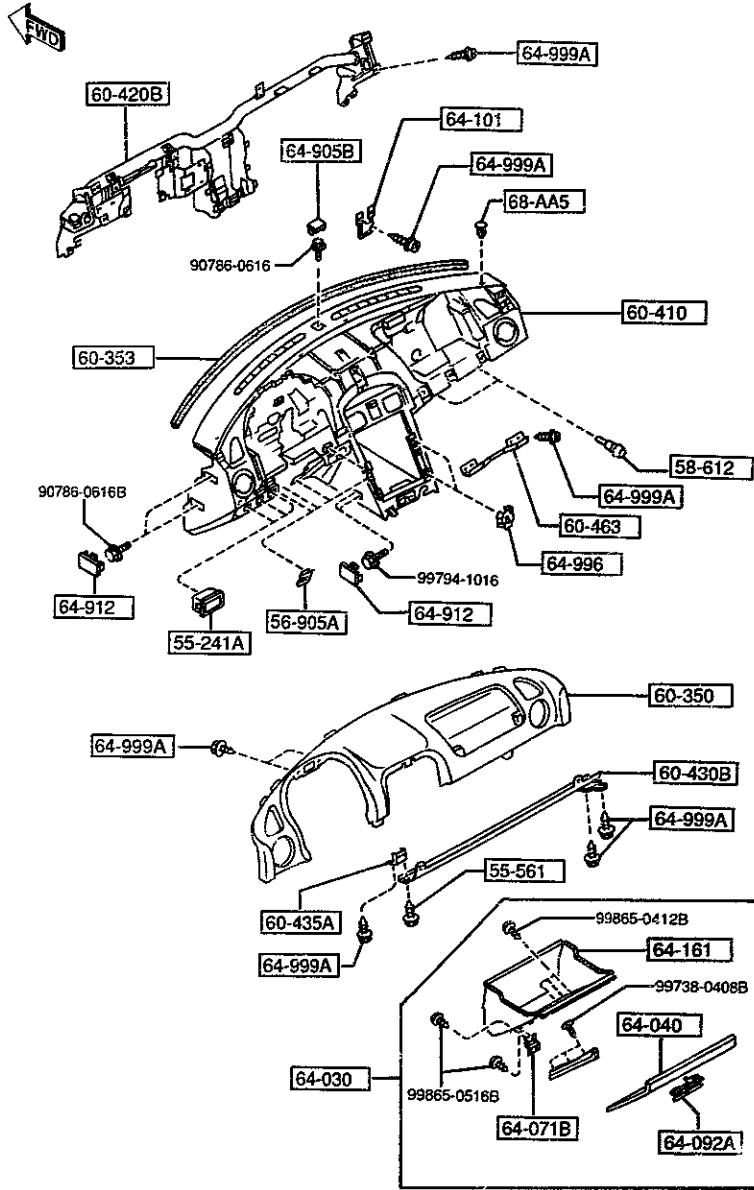

PART NO.	QTY	MODEL/RESTRICTION	MODEL/RESTRICTION	MODEL/RESTRICTION	FROM-TO
55-241A		BOX, INSTRUMENT PANEL			
NA01-55-241A	3				
00	INT-	NA3 NA5 NA4 NA6 BLACK			
55-561		BOLT, INST. PANEL			
B455-55-561	1				
56-905A		NUT, SPRING			
B092-60-408	4				
58-612		CUSHION, RUBBER			
B092-64-046	2				
60-350		PAD, CRASH			
NA75-60-350B	1				
00	INT-	NA3 NA4 NA5 NA6 BLACK			
60-353		RUBBER, URETHNE			
NA75-60-353	1				
60-410		FRAME, INST. PANEL			
NA75-60-401B	1	BASE, PKG-A, PKG-B, PKG-R, (INSTRUMENT PANEL-BL ACK)			-3923
00	INT-	NA3 BLACK			
NA79-60-401B	1	PKG-C, (INSTRUMENT PANEL-TA N)			-3923
88	INT-	NA4 NA5 BLACK/TAN			
NA75-60-401C	1	BASE, PKG-A, PKG-B, PKG-R, (INSTRUMENT PANEL-BL ACK)			3923-3A01
00	INT-	NA3 BLACK			
NA79-60-401C	1	PKG-C, (INSTRUMENT PANEL-TA N)			3923-3A01
88	INT-	NA4 NA5 BLACK/TAN			
NA75-60-401C	1				3A01-3B17
3923 NA3***-504494 3A01 NA3***-505179 3B17 NA3***-506950					

AUNA04

CAT. AUNA04-03

1995-04

5560 DASHBOARD & RELATED PARTS

5560 -2 DASHBOARD & RELATED PARTS

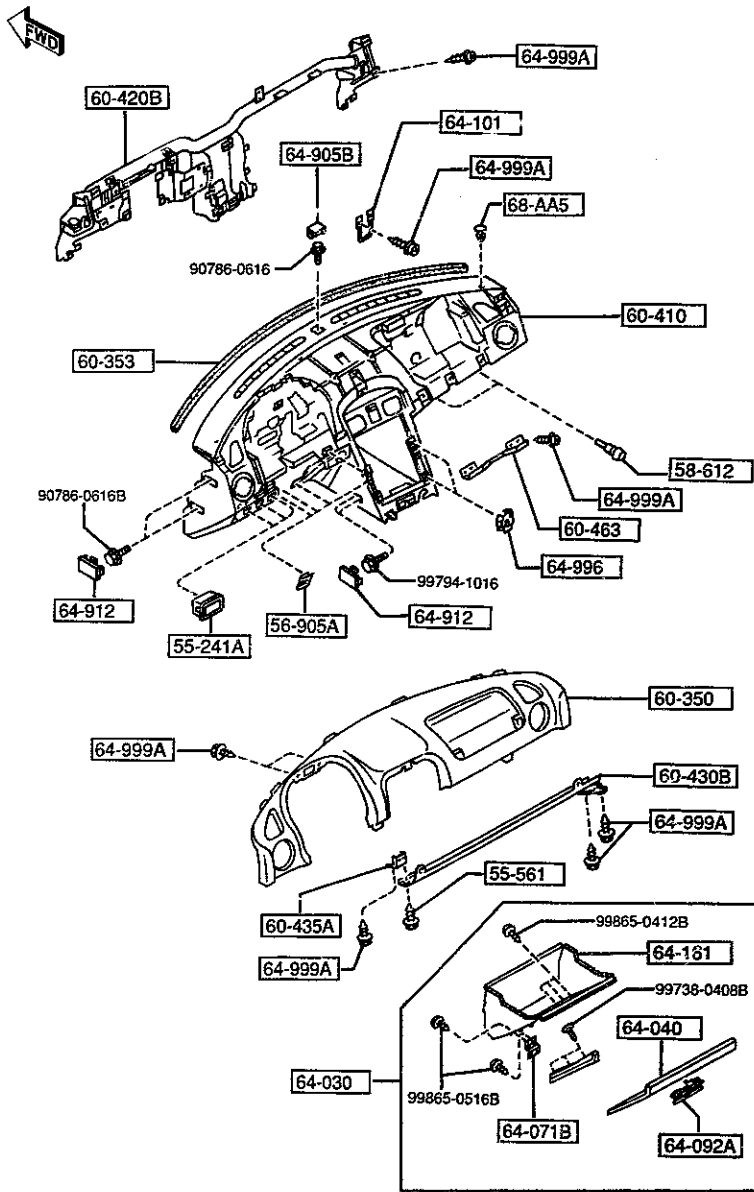

PART NO.	QTY	MODEL/RESTRICTION	MODEL/RESTRICTION	MODEL/RESTRICTION	FROM-TO
CONT'D					
00	INT-	NA3 BLACK			
88	INT-	NA5 BLACK/TAN			
NA75-60-401D	1				3B17-
00	INT-	NA3 BLACK			
88	INT-	NA5 NA4 BLACK/TAN			
60-420B		MEMBER, CRASH PAD			
NA75-60-420A AN(NA75-60-420B)	1				-3B17
NA75-60-420B	1				3B17-
60-430B		MEMBER(R), INST. PANEL			
NA75-60-430	1				
60-435A		BRACKET, MEMBER			
NA01-60-435	1				
60-463		BRACKET, CRASH PAD			
NA01-60-463	1				
64-030		BOX, GLOVE			
NA75-64-030C	1				
00	INT-	NA3 BLACK			
88	INT-	NA4 NA5 TAN			
64-040		LID, GLOVE BOX-OUTER			
NA75-64-041C	1				
00	INT-	NA3 BLACK			
88	INT-	NA4 NA5 TAN			
64-071B		HINGE(R), GLOVE LID			
NA75-64-03XA	2				
64-092A		LOCK, GLOVE LID			
BC5E-64-090	1				-4520
00	INT-	NA3 BLACK			
67	INT-	NA5 NA4 TAN			
64-101		STRIKER			
3B17 NA3***-506950					

AUNA04

CAT. AUNA04-03

1995-04

5560 DASHBOARD & RELATED PARTS

5560 -3 * DASHBOARD & RELATED PARTS

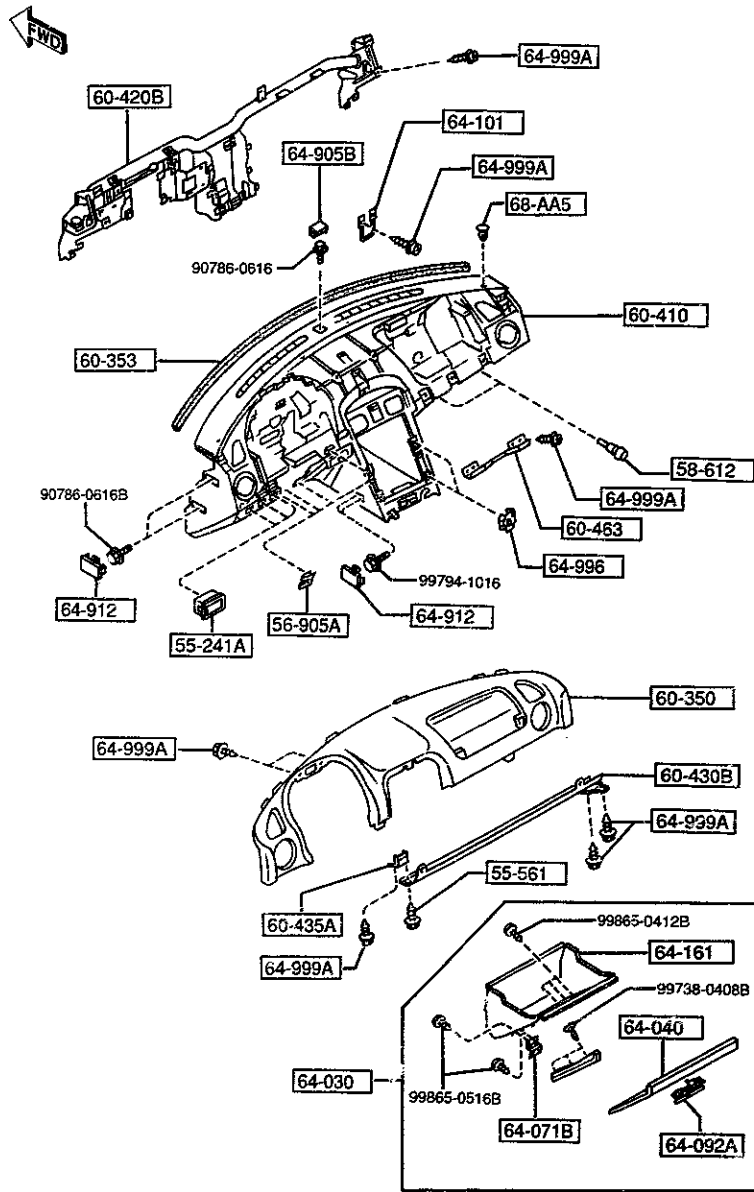

PART NO.	QTY	MODEL/RESTRICTION	MODEL/RESTRICTION	MODEL/RESTRICTION	FROM-TO
CONT'D					
BC1D-64-101	1				
+-----+					
64-161		BOX,GLOVE			
+-----+					
NA75-64-161C	1				
00	INT-	NA3 NA4 NA5 NA6 BLACK			
+-----+					
64-905B		COVER,HOLE-(C)			
+-----+					
NA01-64-905	1	BASE, PKG-A, PKG-B, PKG-R, (INSTRUMENT PANEL-BL ACK)			-3A01
00	INT-	NA3 NA5 NA4 BLACK			
N002-64-905	1	PKG-C, (INSTRUMENT PANEL-TA N)			-3A01
00	INT-	NA5 NA4 BLACK			
NA01-64-905	1				3A01-
00	INT-	NA3 NA5 NA4 BLACK			
+-----+					
64-912		COVER,SIDE			
+-----+					
NA01-64-912	6				
00	INT-	NA3 BLACK			
88	INT-	NA5 NA4 TAN			
+-----+					
64-996		NUT,EXPANSION			
+-----+					
GJ21-64-996	4				
+-----+					
64-999A		SCREW,TAPPING			
+-----+					
W201-64-999	34				
+-----+					
68-AA5		FASTENER,DOOR TRIM			
+-----+					
W201-68-AA5A	4				
00	INT-	NA3 NA5 NA4 NA6 BLACK			
3A01 NA3***-505179					

AUNA04

CAT. AUNA04-03

1995-04

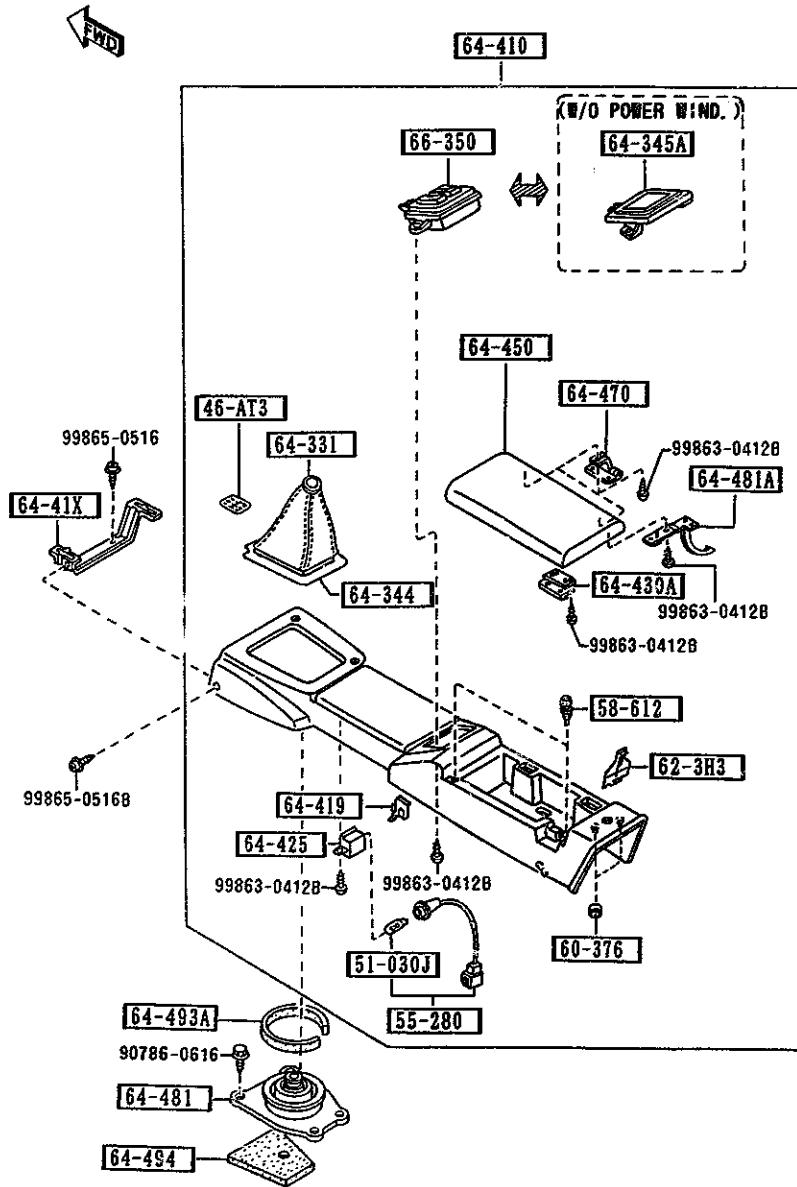

PART NO.	QTY	MODEL/RESTRICTION	MODEL/RESTRICTION	MODEL/RESTRICTION	FROM-TO
46-AT3		LABEL, CHANGE			
N002-46-AT3	1	(WOOD)			
51-030J		BULB			
3625-75-139	1	12V 1.4W, FOR WARNING			
55-280		BULB & SOCKET			
NA01-55-280	1	(MT)			
NA06-55-280	1	(AT)			
58-612		CUSHION, RUBBER			
B092-64-046	2				
60-376		NUT, TOP-CRASH PAD			
B092-60-376	2				
62-3H3		COVER, LEVER-OPENER			
NA01-64-424	1				
64-331		BOOT, CHANGE			
NA01-64-331	1	(MT)			
00	INT-	NA3 NA5 NA4 NA6 BLACK			
64-344		PLATE, BACK-BOOTS RING			
NA01-64-344B	1	(MT)			
64-345A		BOX, COIN-CONSOLE			
NA01-64-437	1	BASE, PKG-A, PKG-R, (W/O POWER WIND.)			
00	INT-	NA3 NA5 NA4 NA6 BLACK			
64-41X		BRACKET, REAR CONSOLE			
NA01-64-416	1				
64-410		CONSOLE, REAR			
NA01-64-410D	1	BASE, PKG-A, (W/O P.WIND, W/O CHANGE LABEL) (MT)			
00	INT-	NA3 NA5 NA4 NA6			

AUNA04

CAT. AUNA04-03

1995-04

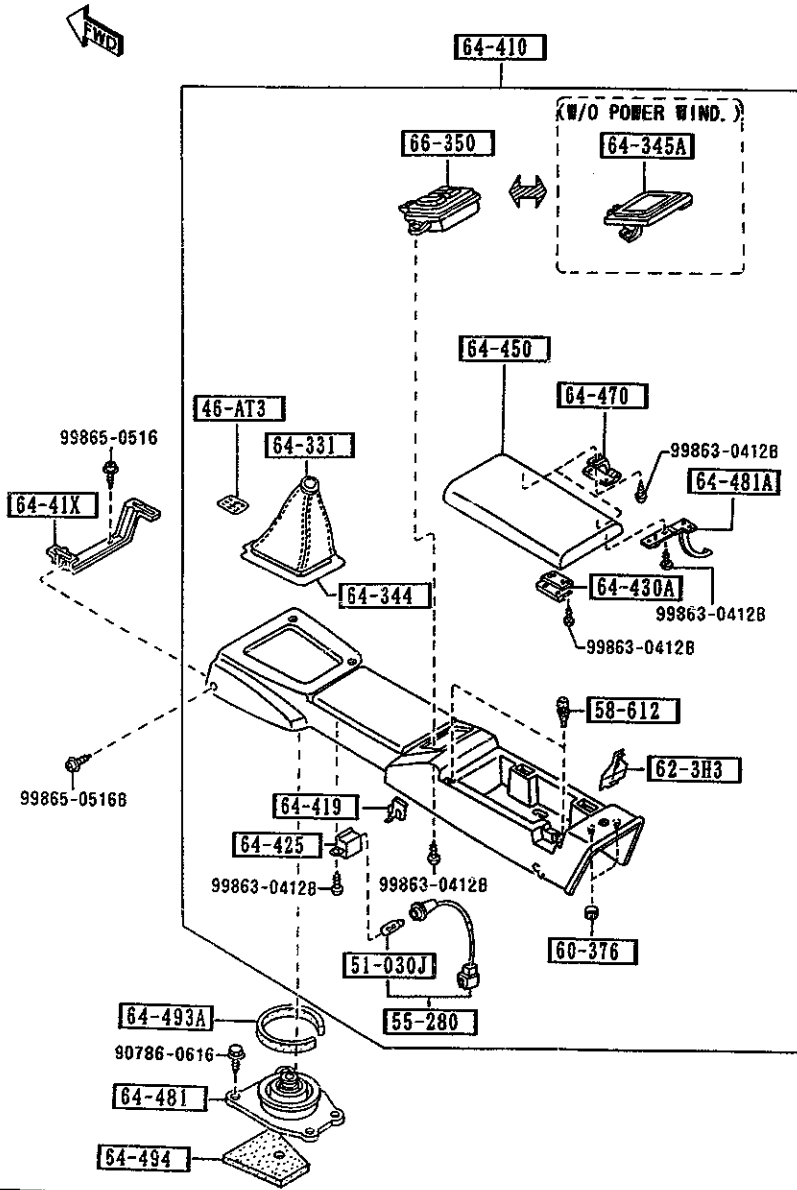

AUNA04

PART NO.	QTY	MODEL/RESTRICTION	MODEL/RESTRICTION	MODEL/RESTRICTION	FROM TO
CDNT'D NA01-64-45XA	2				
00	INT-	NA3 NA5 NA4 NA6 BLACK			
64-481		INSULATOR NO.1,CHAN GE			
NA01-64-481A AN(NA01-64-481B)	1 (MT)				-3C03
NA01-64-481B	1 (MT)				3C03-
64-481A		STOPPER, CONSOLE LID			
NA01-64-452	1				
00	INT-	NA3 NA5 NA4 NA6 BLACK			
64-493A		PACK, SILENT			
H001-64-493	1 (MT)				
64-494		PAD, CHANGE BOOT			
FB01-64-495	1 (MT)				
66-350		SWITCH, POWER WINDOW			
NA01-66-350A	1	PKG-B, PKG-C, RICO-0 PT-PKG, (W/POWER WIND.) (MT)			
00	INT-	NA3 NA5 NA4 NA6 BLACK			
NA03-66-350	1	PKG-B, PKG-C, RICO-0 PT-PKG, (W/POWER WIND.) (AT)			
00	INT-	NA3 NA5 NA4 NA6 BLACK			
3C03 NA3***-507848					

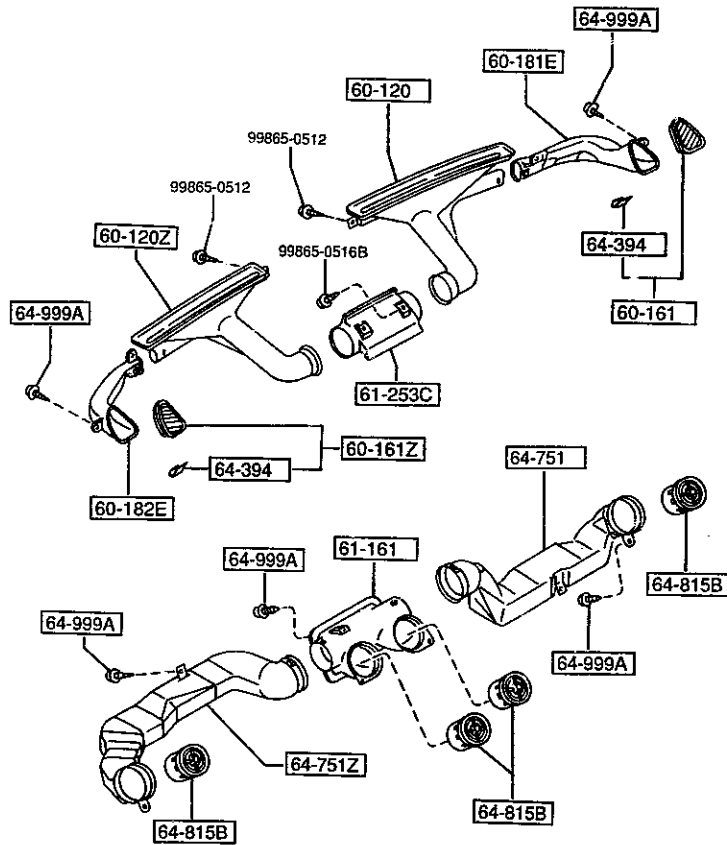

CAT. AUNA04-03

1995-04

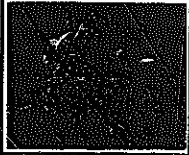
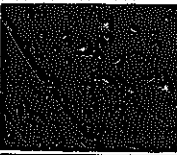

PART NO.	QTY	MODEL/RESTRICTION	MODEL/RESTRICTION	MODEL/RESTRICTION	FROM-TO
60-120		NOZZLE(R),DEFROSTER			
NA75-60-121A A (NA75-60-121B)	1				-4601
*NA75-60-121B	1				4601-
60-120Z		NOZZLE(L),DEFROSTER			
NA01-60-141	1				
60-161		GRILLE(R),DEMISTER			
NA75-60-160A	1	BASE, PKG-A, PKG-B, PKG-R, (INSTRUMENT PANEL-BL ACK)			-3A01
00	INT-	NA3 BLACK			
NA79-60-160A	1	PKG-C, (INSTRUMENT PANEL-TA N)			-3A01
00	INT-	NA4 NA5 BLACK			
NA75-60-160A	1				3A01-
00	INT-	NA3 NA5 NA4 BLACK			
60-161Z		GRILLE(L),DEMISTER			
NA75-60-170A	1	BASE, PKG-A, PKG-B, PKG-R, (INSTRUMENT PANEL-BL ACK)			-3A01
00	INT-	NA3 BLACK			
NA79-60-170A	1	PKG-C, (INSTRUMENT PANEL-TA N)			-3A01
00	INT-	NA4 NA5 BLACK			
NA75-60-170A	1				3A01-
00	INT-	NA3 NA5 NA4 BLACK			
60-181E		DUCT(R),SIDE DEMI.			
NA75-60-183	1				
60-182E		DUCT(L),SIDE DEMI.			
NA75-60-193	1				
61-161		DUCT,CENTER			
NA75-61-161A	1				

3A01 NA3***-505179
4601 NA3***-519089

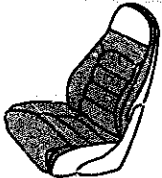
SPECIFICATIONS	TYPE	STB	STA
	GRADE	PKG-C, PKG-C-OPT.	BASE, PKG-A, PKG-B, PKG-R, PKG-B-OPT.
SEAT TRIM	LEATHER		
			

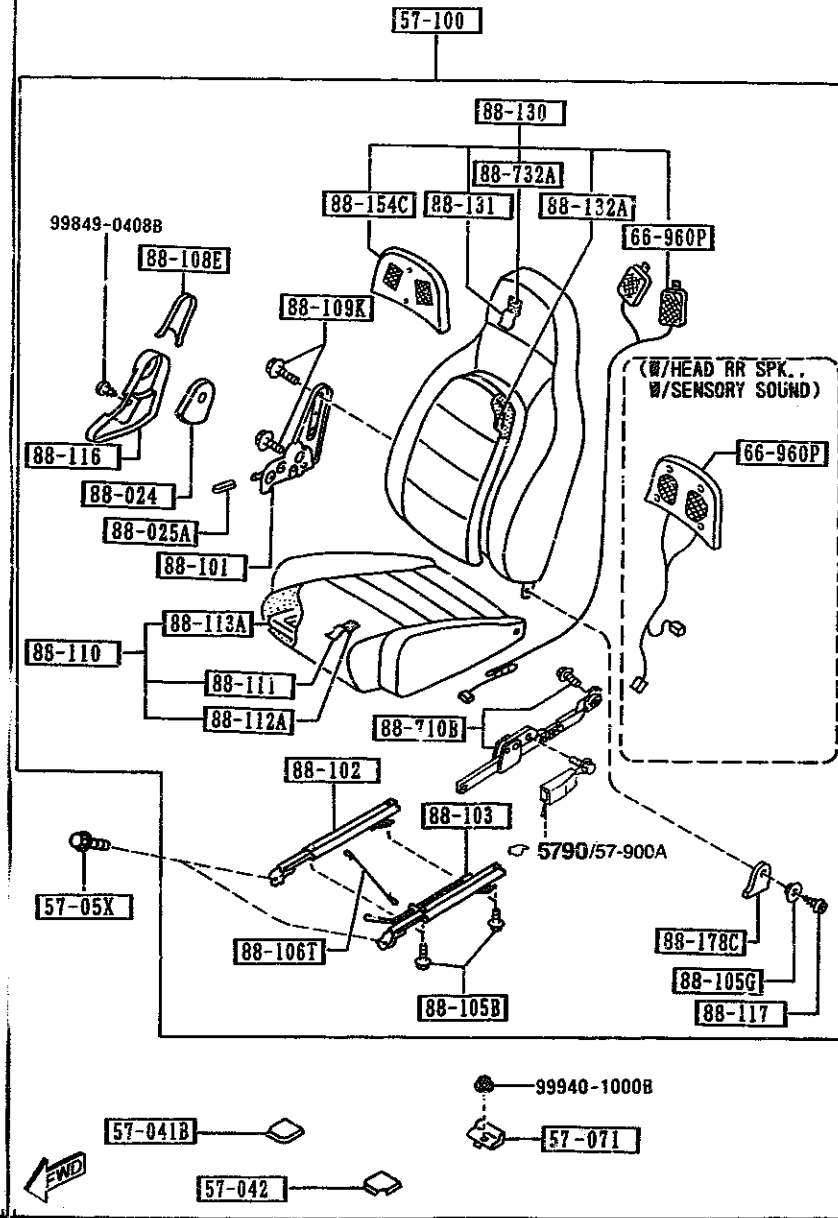

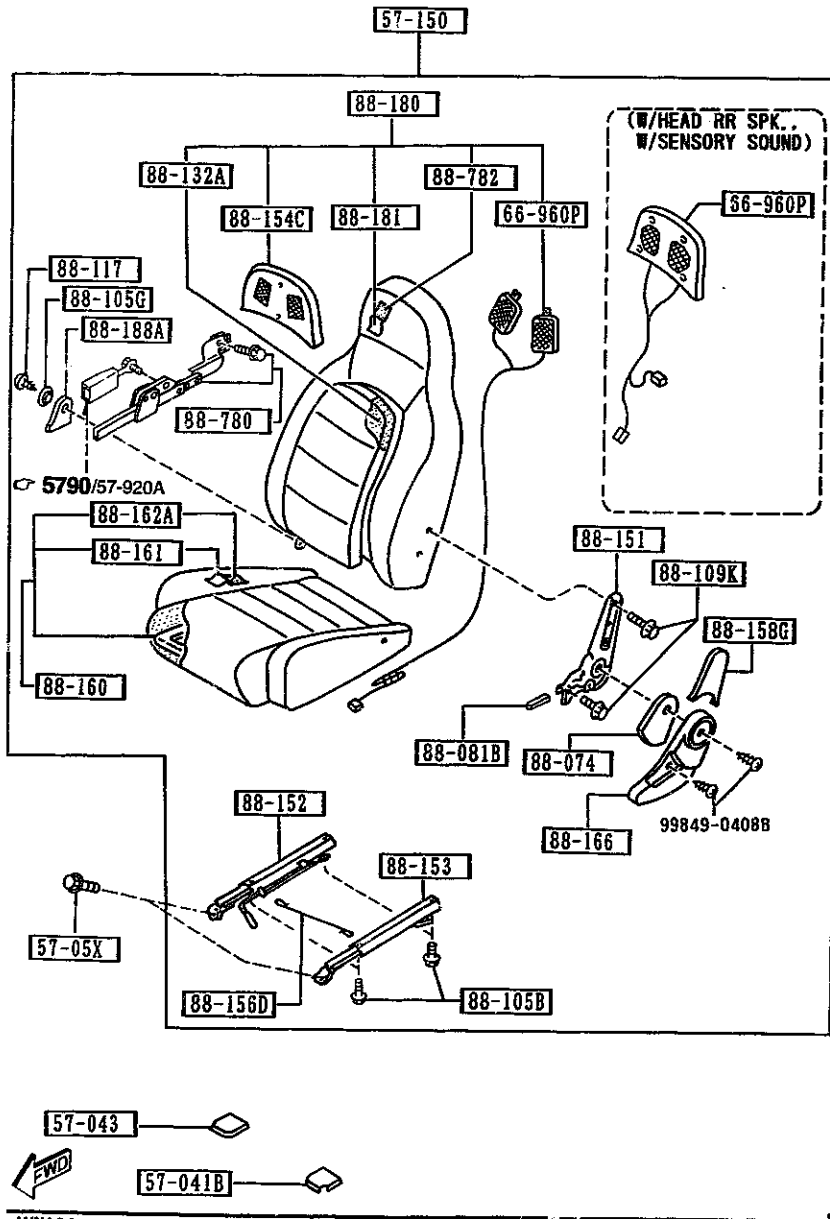

AUNA04

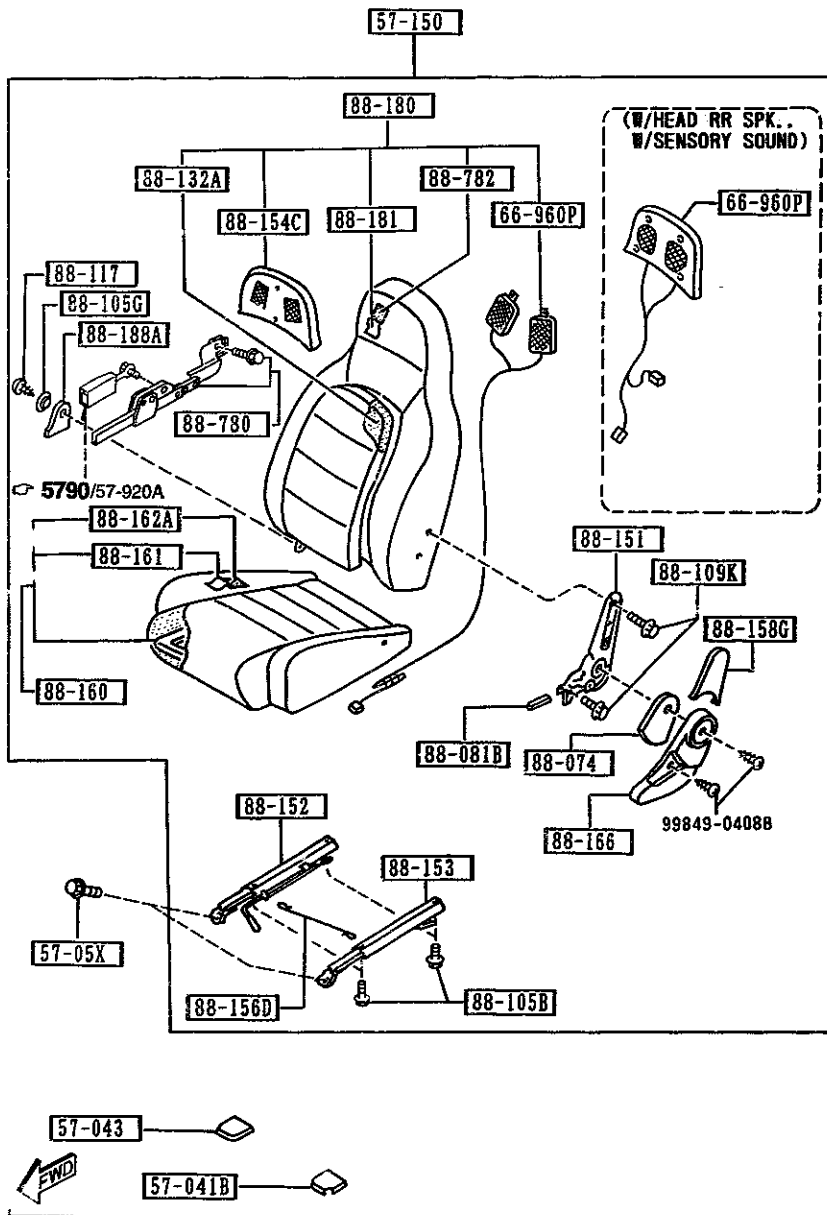

PART NO.	QTY	MODEL/RESTRICTION	MODEL/RESTRICTION	MODEL/RESTRICTION	FROM-TO
CONT'D					
88	INT-	NA4 NA5 TAN			
NA75-57-100A	1	BASE, PKG-R, (STA TYPE,W/O HEAD S PEAKER)			3B02-4201
00	INT-	NA3 BLACK			
NA79-57-100A	1	PKG-A, PKG-B, (STA TYPE,W/HEAD SPE AKER, W/O SENSORY SO UND)			3B02-4201
00	INT-	NA3 BLACK			
NA80-57-100A	1	PKG-B-OPT, (STA TYPE,W/HEAD SPE AKER, W/SENSORY SOUN D)			3B02-4201
00	INT-	NA3 BLACK			
NA75-57-100C	1	BASE, PKG-R, (STA TYPE,W/O HEAD S PEAKER)			4201-
00	INT-	NA3 BLACK			
NA79-57-100C	1	PKG-A, PKG-B, (STA TYPE,W/HEAD SPE AKER, W/O SENSORY SO UND)			4201-
00	INT-	NA3 BLACK			
NA80-57-100C	1	PKG-B-OPT, (STA TYPE,W/HEAD SPE AKER, W/SENSORY SOUN D)			4201-
00	INT-	NA3 BLACK			
NA81-57-100D	1	PKG-C, (STB TYPE,W/HEAD SPE AKER, W/O SENSORY SO UND)			4201-
88	INT-	NA4 NA5 TAN			
NA82-57-100D	1	PKG-C-OPT, (STB TYPE,W/HEAD SPE AKER, W/SENSORY SOUN D)			4201-
88	INT-	NA4 NA5 TAN			
57-150		SEAT(L),FRONT			
NA75-57-150	1	BASE, PKG-R, (STA TYPE,W/O HEAD S PEAKER) (N.AMERICA)			-3B02
00	INT-	NA3 BLACK			
3B02 NA3***-505896 4201 NA3***-511601					

AUNA04

CAT. AUNA04-03

1995-04

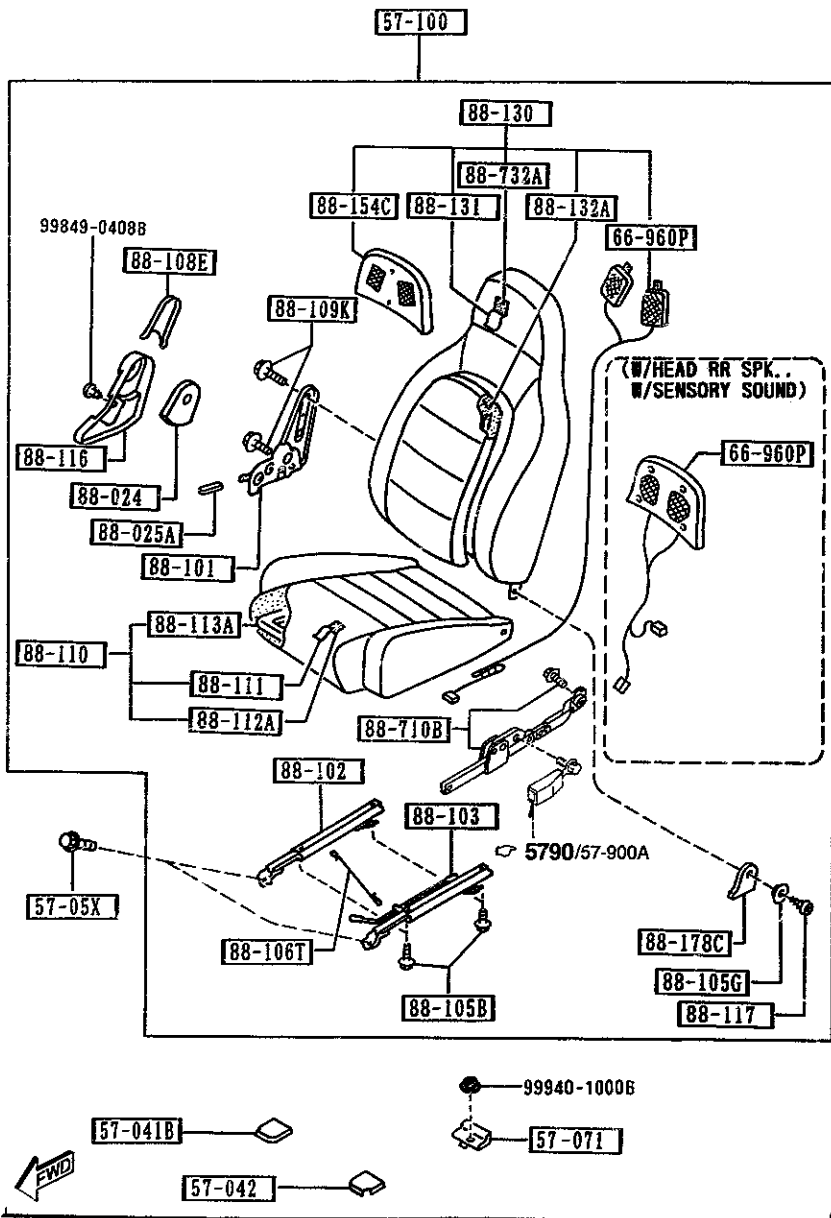

PART NO.	QTY	MODEL/RESTRICTION	MODEL/RESTRICTION	MODEL/RESTRICTION	FRGM-TO
CONT'D					
NA79-57-150	1	PKG-A, PKG-B, (STA TYPE, W/HEAD SPEAKER, W/O SENSORY SOUND) (N.AMERICA)			-3802
00	INT-	NA3 BLACK			
NA80-57-150	1	PKG-B-OPT, (STA TYPE, W/HEAD SPEAKER, W/SENSORY SOUND)			-3802
00	INT-	NA3 BLACK			
NA81-57-150B	1	PKG-C, (STB TYPE, W/HEAD SPEAKER, W/O SENSORY SOUND)			-4201
88	INT-	NA4 NA5 TAN			
NA82-57-150B	1	PKG-C-OPT, (STB TYPE, W/HEAD SPEAKER, W/SENSORY SOUND)			-4201
88	INT-	NA4 NA5 TAN			
NA75-57-150A	1	BASE, PKG-R, (STA TYPE, W/O HEAD SPEAKER)			3802-4201
00	INT-	NA3 BLACK			
NA79-57-150A	1	PKG-A, PKG-B, (STA TYPE, W/HEAD SPEAKER, W/O SENSORY SOUND)			3802-4201
00	INT-	NA3 BLACK			
NA80-57-150A	1	PKG-B-OPT, (STA TYPE, W/HEAD SPEAKER, W/SENSORY SOUND)			3802-4201
00	INT-	NA3 BLACK			
NA75-57-150C	1	BASE, PKG-R, (STA TYPE, W/O HEAD SPEAKER)			4201-
00	INT-	NA3 BLACK			
NA79-57-150C	1	PKG-A, PKG-B, (STA TYPE, W/HEAD SPEAKER, W/O SENSORY SOUND)			4201-
00	INT-	NA3 BLACK			
NA80-57-150C	1	PKG-B-OPT, (STA TYPE, W/HEAD SPEAKER, W/SENSORY SOUND)			4201-
00	INT-	NA3 BLACK			
3802 NA3***-505896					
4201 NA3***-511601					

AUNA04

CAT. AUNA04-03

1995-04

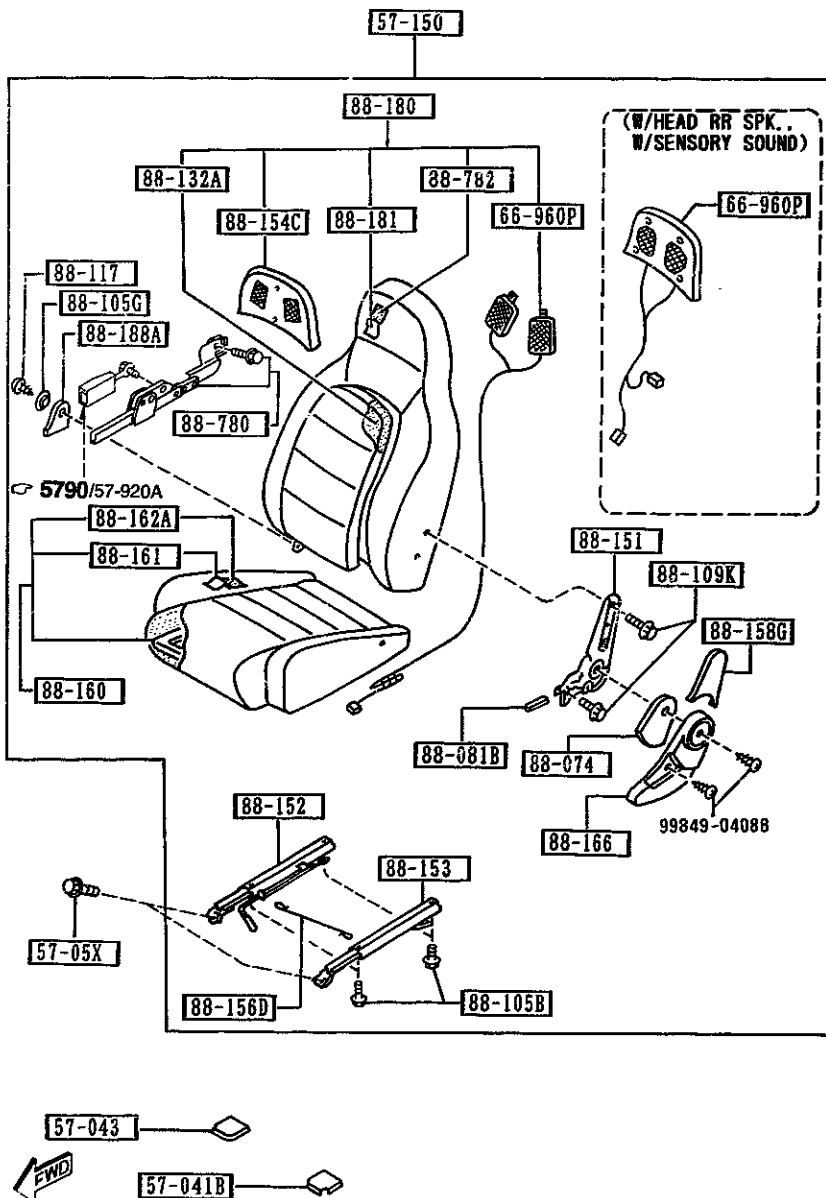

PART NO.	QTY	MODEL/RESTRICTION	MODEL/RESTRICTION	MODEL/RESTRICTION	FROM-TO
CONT'D					
NA81-57-150D	1	PKG-C, (STB TYPE, W/HEAD SPEAKER, W/O SENSORY SOUND)			4201-
88	INT-	NA4 NA5 TAN			
NA82-57-150D	1	PKG-C-OPT, (STB TYPE, W/HEAD SPEAKER, W/SENSORY SOUND)			4201-
88	INT-	NA4 NA5 TAN			
66-960P		SPEAKER, PILLOW-SEAT			
NA04-66-960B	2	PKG-A, PKG-B, PKG-C, (W/HEAD RR SPK., W/O SENSORY SOUND)			
NA020-66-960A	2	PKG-B-OPT, PKG-C-OPT (W/HEAD RR SPK., W/SENSORY SOUND)			
88-C24		PROTR(R), SEAT BELT			
NA01-88-033	1				
88-025A		KNOB(R), KNUCKLE			
NA01-88-034	1				
00	INT-	NA3 BLACK			
88	INT-	NA5 NA4 TAN			
88-074		PROTR(L), SEAT BELT			
NA01-88-083	1				
88-081B		KNOB(L), KNUCKLE			
NA01-88-084	1				
00	INT-	NA3 BLACK			
88	INT-	NA5 NA4 TAN			
88-101		KNUCKLE(R), RECLINING			
NA01-88-101A	1				
88-102		ADJUSTER, NO.1			
NA01-88-102A	1				
88-103		ADJUSTER, NO.2			
NA75-88-103	1				
4201 NA3***-511601					

AUNA04

CAT. AUNA04-03

1995-04

2-J 8

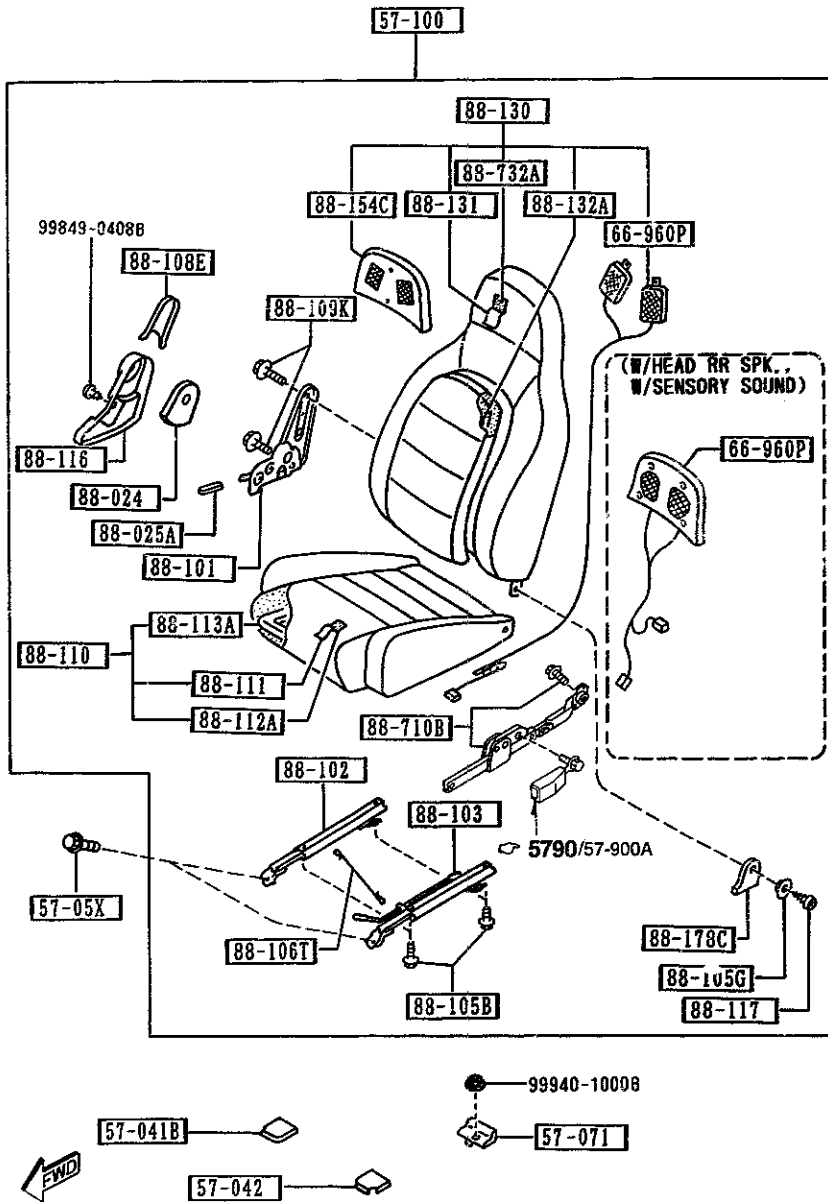

PART NO.	QTY	MODEL/RESTRICTION	MODEL/RESTRICTION	MODEL/RESTRICTION	FROM-TO
88-105B		BOLT, LINK			
H260-88-105	8				
88-105G		BUSH, HINGE			
H260-88-108	2				
02	INT-	NA3 NA5 NA4 NA6 BLACK			
88-106T		WIRE, CONNECT			
NA01-88-106	1				
88-108E		COVER(R), SEAT BACK			
NA01-88-036	1				
00	INT-	NA3 BLACK			
88	INT-	NA5 NA4 TAN			
88-109K		SCREW, KNUCKLE			
H260-88-199	8				
88-110		CUSHION(R), FRT SEAT			
NA75-88-110	1	BASE, PKG-A, PKG-B, PKG-R, (STA TYPE)			
00	INT-	NA3 BLACK			
NA01-88-110	1	PKG-C, (STB TYPE)			
88	INT-	NA5 NA4 TAN			
88-111		TRIM(R), SEAT CUSHION			
NA75-88-111	1	BASE, PKG-A, PKG-B, PKG-R, (STA TYPE)			
00	INT-	NA3 BLACK			
NA01-88-111	1	PKG-C, (STB TYPE)			
88	INT-	NA5 NA4 TAN			
88-112A		PAD(R), CUSHION-FRT			
N001-88-112	1				-4201
AN(NA75-88-112)					
N005-88-112	1				-4201
AN(NA01-88-112)					
4201 NA3***-511601					

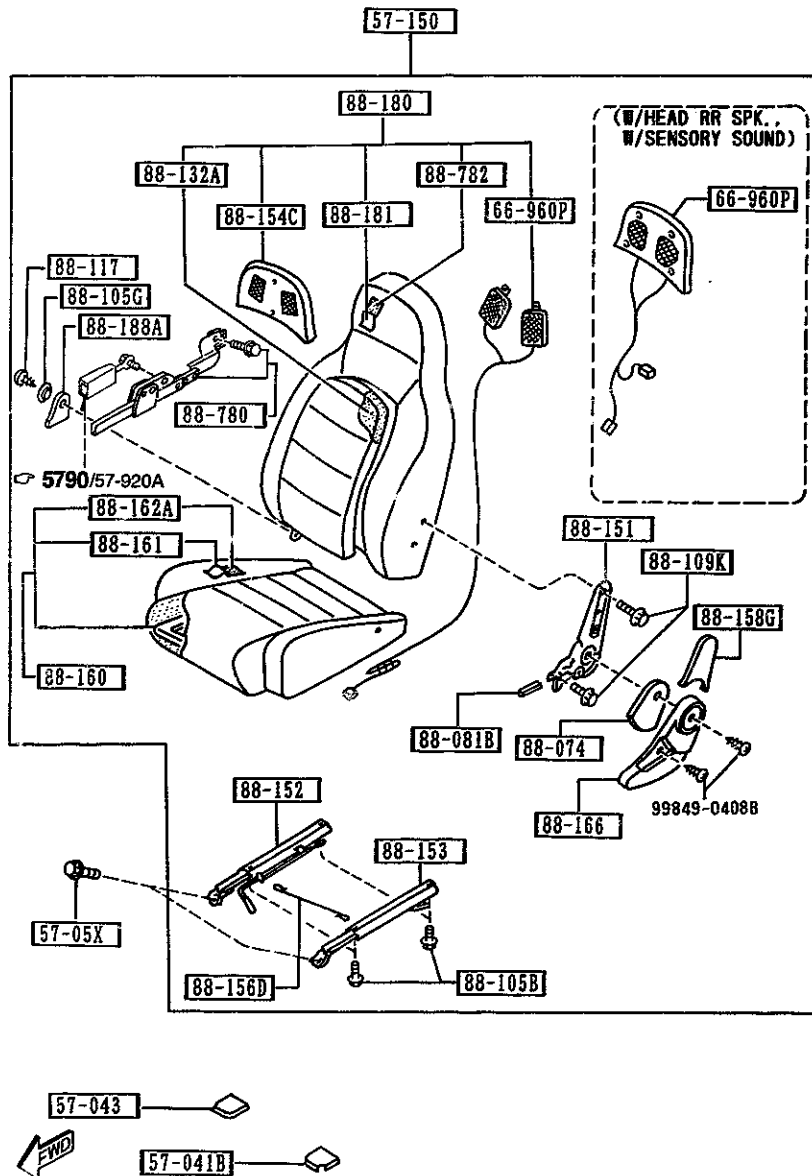

PART NO.	QTY	MODEL/RESTRICTION	MODEL/RESTRICTION	MODEL/RESTRICTION	FROM-TO
CONT'D					
NA75-88-112	1	BASE, PKG-A, PKG-B, PKG-R, (STA TYPE)			4201-
NA81-88-112	1	PKG-C, (STB TYPE)			4201-
88-113A		FRAME(R), CUSHION-FRT			
NA75-88-113	1				
88-116		COVER(R), KNUCKLE			
NA01-88-051	1				
00	INT-	NA3 BLACK			
88	INT-	NA5 NA4 TAN			
88-117		SCREW, KNUCKLE			
H260-88-107	2				
88-130		BACK(R), FRONT SEAT			
NA75-88-130	1	BASE, PKG-R, (STA TYPE, W/O HEAD S PEAKER)			
00	INT-	NA3 BLACK			
NA79-88-130	1	PKG-A, PKG-B, (STA TYPE, W/HEAD SPE AKER, W/O SENSORY SO UND)			
00	INT-	NA3 BLACK			
NA80-88-130	1	PKG-B-OPT, (STA TYPE, W/HEAD SPE AKER, W/SENSORY SOUN D)			
00	INT-	NA3 BLACK			
NA82-88-130	1	PKG-C-OPT, (STB TYPE, W/HEAD SPE AKER, W/SENSORY SOUN D)			
88	INT-	NA5 NA4 TAN			
NA23-88-130B	1	PKG-C, (STB TYPE, W/HEAD SPE AKER, W/O SENSORY SO UND)			-4201
88	INT-	NA5 NA4 TAN			
NA81-88-130	1	PKG-C, (STB TYPE, W/HEAD SPE AKER, W/O SENSORY SO UND)			4201-
4201 NA3***-511601					

AUNA04

CAT. AUNA04-03

1995-06

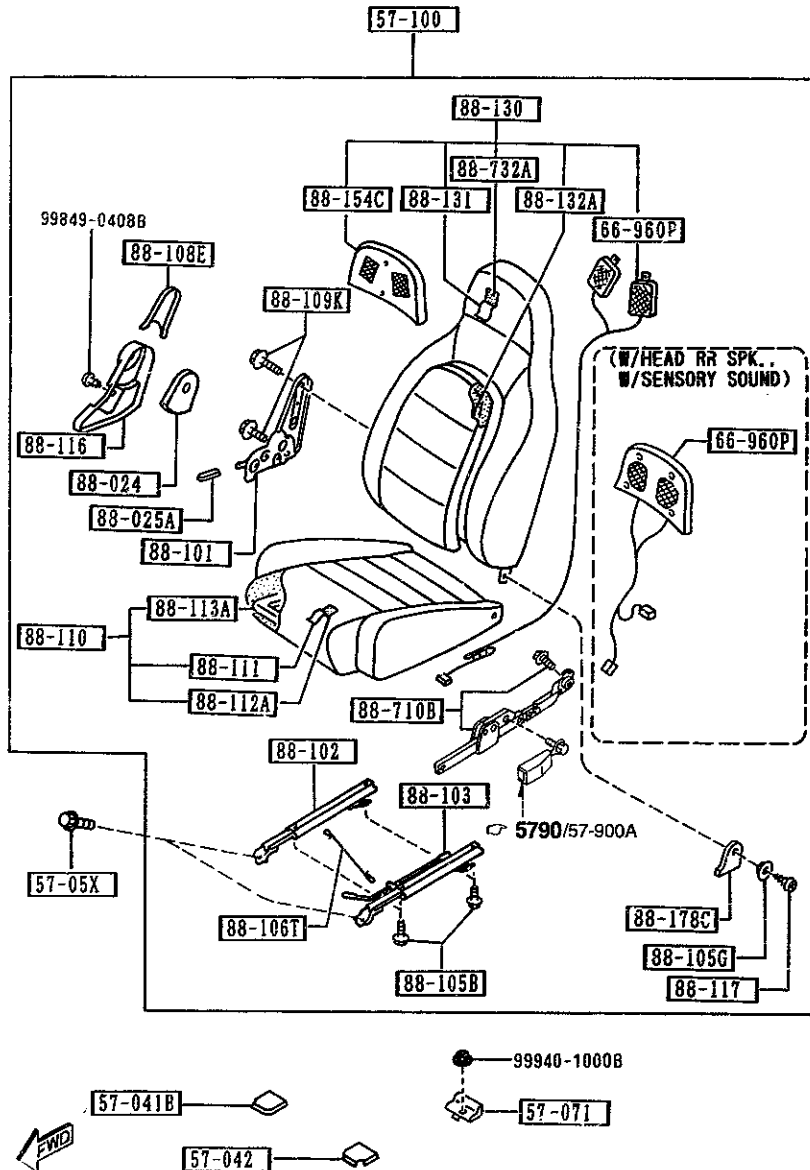

PART NO.	QTY	MODEL/RESTRICTION	MODEL/RESTRICTION	MODEL/RESTRICTION	FROM TO
CONT'D					
88	INT-	NA4 NA5 TAN			
88-131		TRIM(R),SEAT BACK			
NA75-88-131	1	BASE, PKG-A, PKG-B, PKG-R, (STA TYPE,W/O SENSOR Y SOUND)			
00	INT-	NA3 BLACK			
NA80-88-131	1	PKG-B-OPT, (STA TYPE,W/SENSORY SOUND)			
00	INT-	NA3 BLACK			
NA82-88-131	1	PKG-C,OPT, (STB TYPE,W/SENSORY SOUND)			
88	INT-	NA5 NA4 TAN			-4201
NA23-88-131	1	PKG-C, (STB TYPE,W/O SENSOR Y SOUND)			
88	INT-	NA5 NA4 TAN			4201-
NA81-88-131	1	PKG-C, (STB TYPE,W/O SENSOR Y SOUND)			
88	INT-	NA4 NA5 TAN			
88-132A		PAD(R),BACK-FRT			
NA01-88-132A	2	(IN SPITE OF (R),THIS PART IS APPLICABLE TO BOTH RH&LH SIDE) (W/O SENSORY SOUND)			
88-151		KNUCKLE(L),RECLINING			
NA01-88-151A	1				
88-152		ADJUSTER NO.3			
NA01-88-152A	1				
88-153		ADJUSTER NO.4			
NA01-88-153A	1				
88-154C		COVER,HEAD REST			
NA01-88-137	2	(W/O SENSORY SOUND)			
88-156D		WIRE,CONNECT			
4201 NA3***-511601					

AUNA04

CAT. AUNA04-03

1995-04

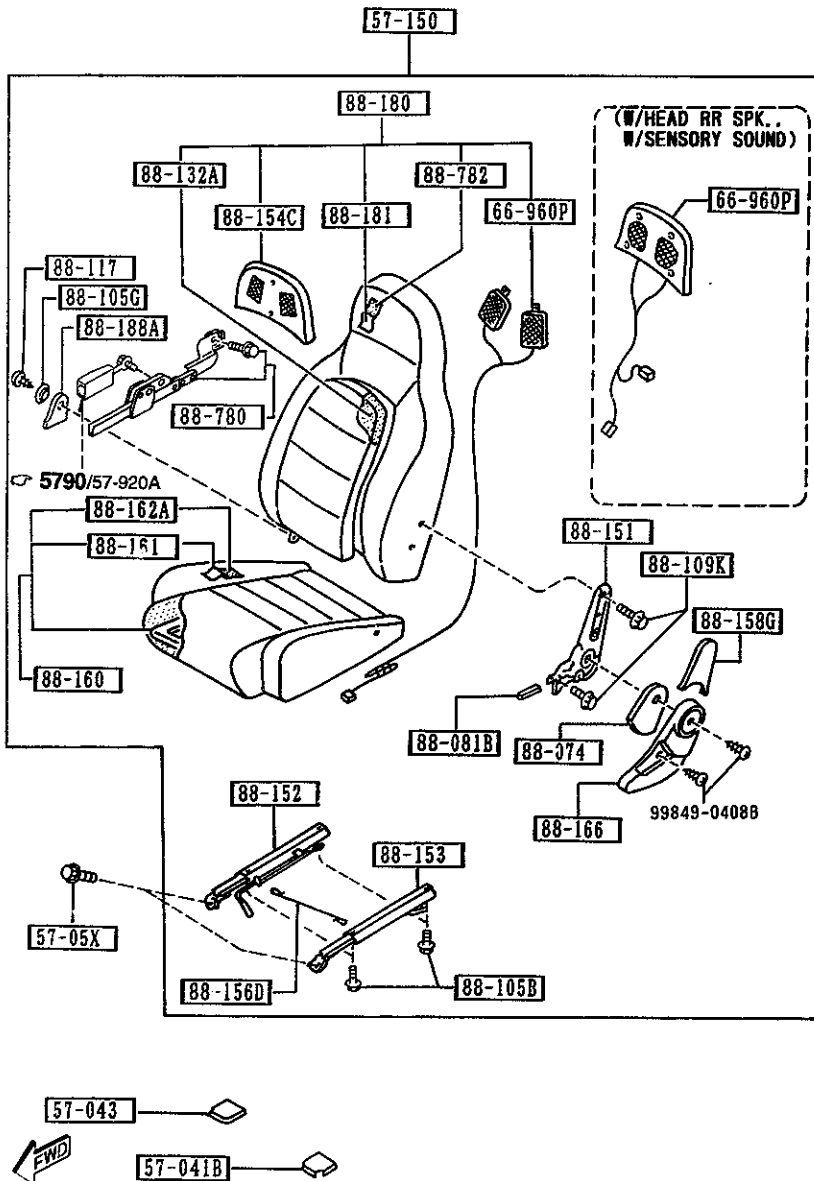

PART NO.	QTY	MODEL/RESTRICTION	MODEL/RESTRICTION	MODEL/RESTRICTION	FROM-TO
CONT'D					
NA01-88-156	1				
88-158G		COVER(L),SEAT BACK			
NA01-88-086	1				
00	INT-	NA3 BLACK			
88	INT-	NA5 NA4 TAN			
88-160		CUSHION(L),FRT SEAT			
NA75-88-160	1	BASE, PKG-A, PKG-B, PKG-R, (STA TYPE)			
00	INT-	NA3 BLACK			
NA81-88-160	1	PKG-C, (STB TYPE)			
88	INT-	NA5 NA4 TAN			
88-161		TRIM(L),SEAT CUSHION			
NA75-88-161	1	BASE, PKG-A, PKG-B, PKG-R, (STA TYPE)			
00	INT-	NA3 BLACK			
NA81-88-161	1	PKG-C, (STB TYPE)			
88	INT-	NA5 NA4 TAN			
88-162A		PAD(L),CUSHION-FRT			
NA01-88-162	1	BASE, PKG-A, PKG-B, PKG-R, (STA TYPE)			-4201
N805-88-162	1	PKG-C, (STB TYPE)			-4201
88-166		COVER(L),KNUCKLE			
NA01-88-081	1				
00	INT-	NA3 BLACK			
88	INT-	NA5 NA4 TAN			
88-178C		COVER(R),HINGE			
NA75-88-035	1				-4201
00	INT-	NA3 BLACK			
88	INT-	NA5 NA4 TAN			
NA01-88-035	1				4201-
4201 NA3***-511601					

AUNA04

CAT. AUNA04-03

1995-04

2-N 8

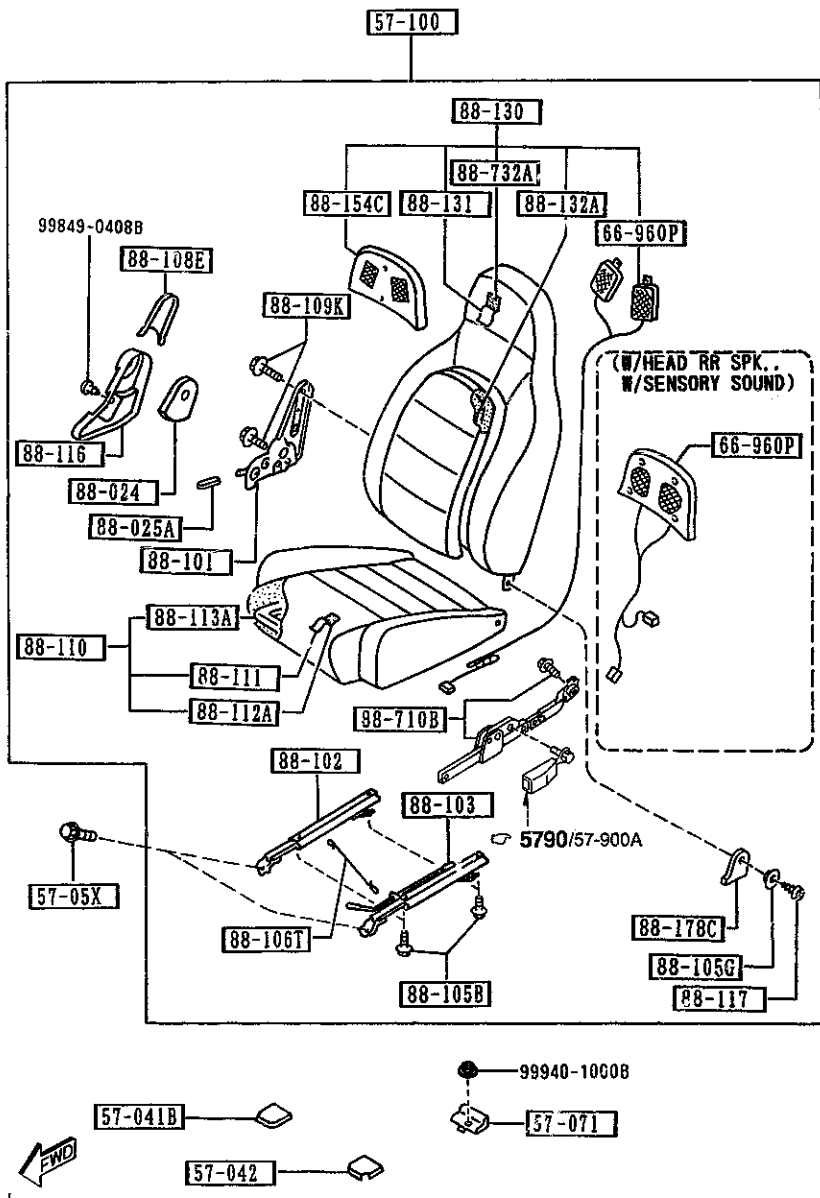

PART NO.	QTY	MODEL/RESTRICTION	MODEL/RESTRICTION	MODEL/RESTRICTION	FROM-TO
CONT'D					
00	INT-	NA3 BLACK			
88	INT-	NA4 NA5 TAN			
88-180		BACK(L),FRONT SEAT			
NA75-88-180	1	BASE, PKG-R, (STA TYPE,W/O HEAD S PEAKER)			
00	INT-	NA3 BLACK			
NA79-88-180	1	PKG-A, PKG-B, (STA TYPE,W/HEAD SPE AKER, W/O SENSORY SO UND)			
00	INT-	NA3 BLACK			
NA80-88-180	1	PKG-B-OPT, (STA TYPE,W/HEAD SPE AKER, W/SENSORY SOUN D)			
00	INT-	NA3 BLACK			
NA82-88-180	1	PKG-C-OPT, (STB TYPE,W/HEAD SPE AKER, W/SENSORY SOUN D)			
88	INT-	NA5 NA4 TAN			-4201
NA23-88-180B	1	PKG-C, (STB TYPE,W/HEAD SPE AKER, W/O SENSORY SO UND)			
88	INT-	NA5 NA4 TAN			4201-
NA81-88-180	1	PKG-C, (STB TYPE,W/HEAD SPE AKER, W/O SENSORY SO UND)			
88	INT-	NA4 NA5 TAN			
88-181		TRIM(L),SEAT BACK			
NA75-88-181	1	BASE, PKG-A, PKG-B, PKG-R, (STA TYPE,W/O SENSOR Y SOUND)			
00	INT-	NA3 BLACK			
NA80-88-181	1	PKG-B-OPT, (STA TYPE,W/SENSORY SOUND)			
00	INT-	NA3 BLACK			
NA82-88-181	1	PKG-C,OPT, (STB TYPE,W/SENSORY SOUND)			
4201 NA3***-511601					

AUNA04

CAT. AUNA04-03

1995-04

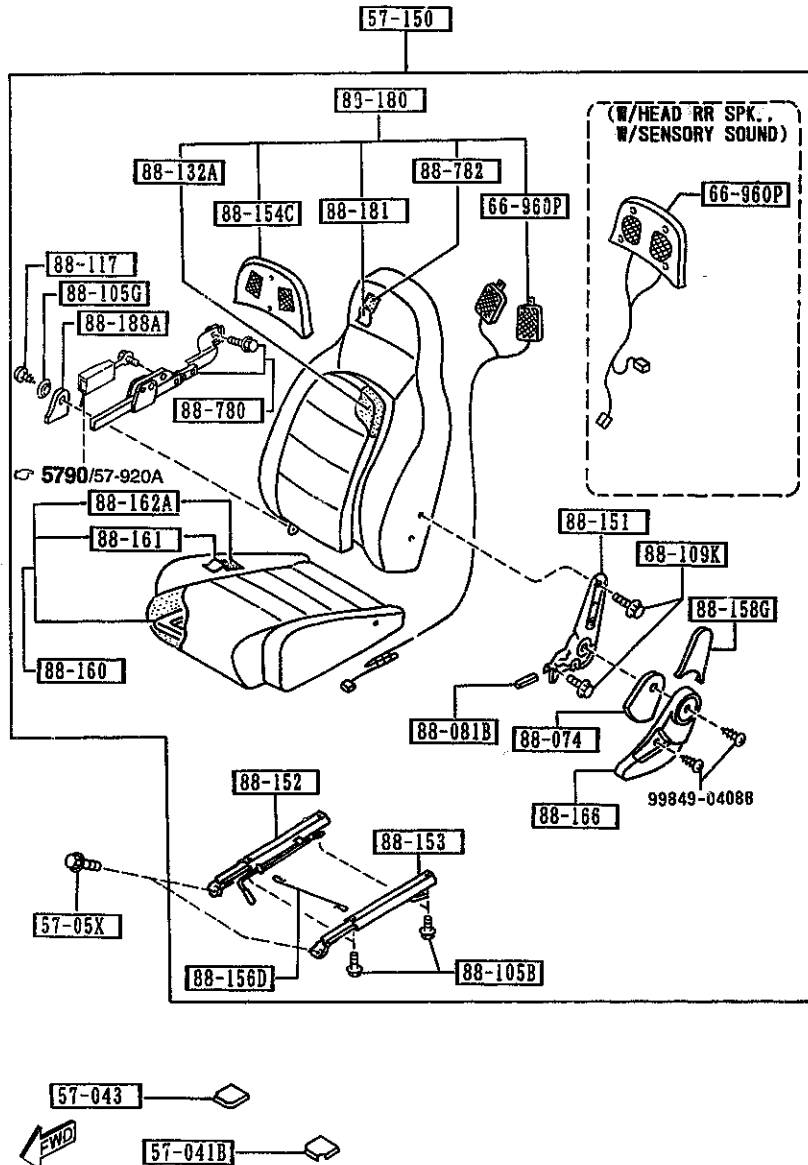

PART NO.	QTY	MODEL/RESTRICTION	MODEL/RESTRICTION	MODEL/RESTRICTION	FRGM-TO
CONT'D					
88	INT-	NA5 NA4 TAN			
NA23-88-181	1	PKG-C, (STB TYPE,W/O SENSOR Y SOUND)			-4201
88	INT-	NA5 NA4 TAN			
NA81-88-181	1	PKG-C, (STB TYPE,W/O SENSOR Y SOUND)			4201-
88	INT-	NA4 NA5 TAN			
+-----+		88-188A	COVER(L),HINGE		
NA75-88-085	1				-4201
00	INT-	NA3 BLACK			
88	INT-	NA5 NA4 TAN			
NA01-88-085	1				4201-
00	INT-	NA3 BLACK			
88	INT-	NA4 NA5 TAN			
+-----+		88-710B	ANCHOR UNIT(R),BELT		
*NA75-88-710	1				
+-----+		88-732A	PAD'B'(R),BACK-FRT		
NA01-88-732A	1		(W/O SENSORY SOUND)		
+-----+		88-789	ANCHOR UNIT(L),BELT		
*NA75-88-760	1				
+-----+		88-782	PAD'B'(L),BACK-FRT		
NA01-88-782A	1		(W/O SENSORY SOUND)		

4201 NA3***-511601

AUNA04

CAT. AUNA04-03

1995-04

5790 SEAT BELTS

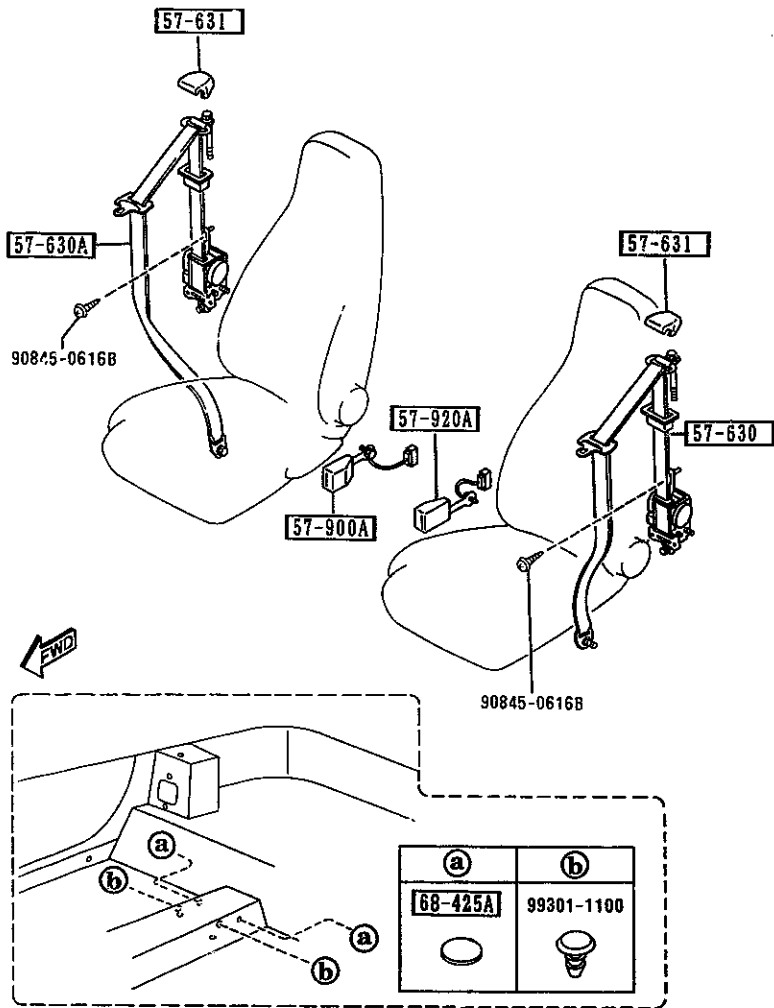

AUNA04

5790 -1 SEAT BELTS

PART NO.	QTY	MODEL/RESTRICTION	MODEL/RESTRICTION	MODEL/RESTRICTION	FROM-TO
57-630		BELT*B*,FRT SEAT			
NA82-57-630D	1	NON USA,			
00	INT-	NA3 BLACK			
88	INT-	NA4 NA5 TAN/BLACK			
NA76-57-630	1	(W/AIR BAG-DRIV.&PAS S.SIDE)			-3901
00	INT-	NA3 BLACK			
88	INT-	NA4 NA5 TAN/BLACK			
NA76-57-630B	1	(W/AIR BAG-DRIV.&PAS S.SIDE)			3901-3801
00	INT-	NA3 BLACK			
88	INT-	NA4 NA5 TAN/BLACK			
NA76-57-630C	1	(W/AIR BAG-DRIV.&PAS S.SIDE)			3801-3824
00	INT-	NA3 BLACK			
88	INT-	NA4 NA5 TAN/BLACK			
NA76-57-630D	1	(W/AIR BAG-DRIV.&PAS S.SIDE)			3824-
00	INT-	NA3 BLACK			
88	INT-	NA4 NA5 TAN/BLACK			
57-630A		BELT*B*(R),FRT SEAT			
NA75-57-630D	1				-3801
00	INT-	NA3 BLACK			
88	INT-	NA4 NA5 TAN			
NA75-57-630E	1				3801-3824
00	INT-	NA3 BLACK			
88	INT-	NA4 NA5 TAN			
NA75-57-630F	1				3824-
00	INT-	NA3 BLACK			
88	INT-	NA4 NA5 TAN			
57-631		COVER,ANCHOR			
N026-57-631	2				
00	INT-	NA3 NA5 NA4 NA6 BLACK			
57-900A		BELT*A*(R),FRT SEAT			
3901	NA3***	502360			
3801	NA3***	505807			
3824	NA3***	507313			

CAT. AUNA04-03

1995-04

5790 SEAT BELTS

5790 -2 * SEAT BELTS

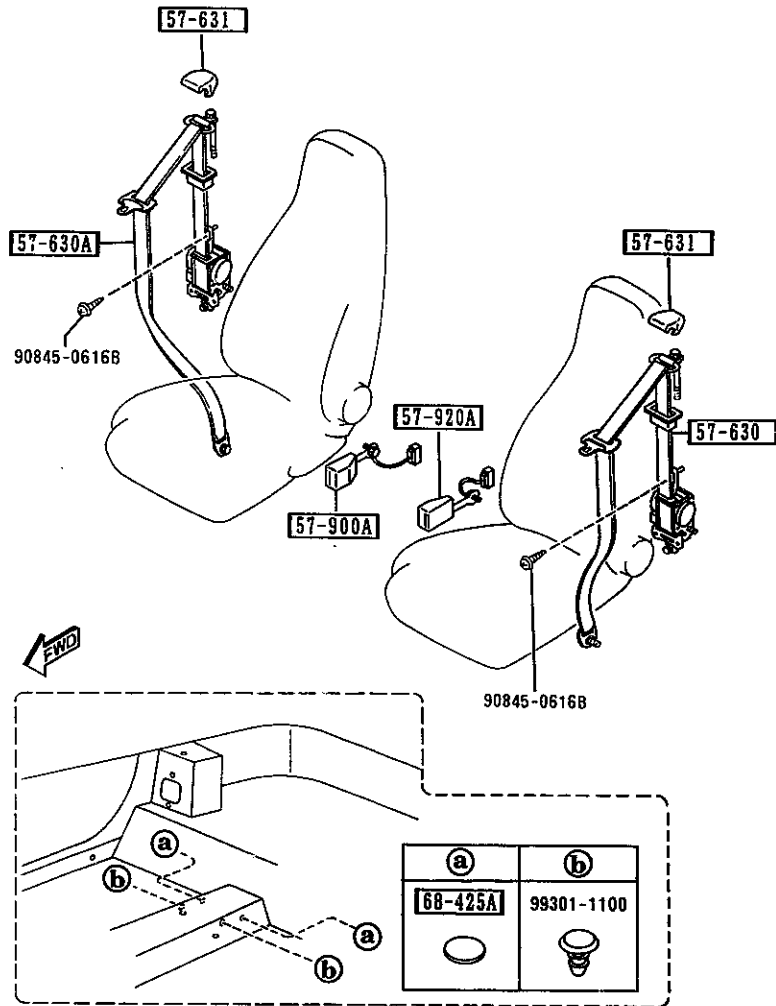

PART NO.	QTY	MODEL/RESTRICTION	MODEL/RESTRICTION	MODEL/RESTRICTION	FROM-TO
CONT'D					
NA75-57-620	1				
00	INT-	NA3 NA5 NA4 BLACK			
↑-----↑					
57-920A		BELT'A'(L),FRT SEAT			
↑-----↑					
NA75-57-680A	1				
00	INT-	NA3 NA5 NA4 BLACK			
↑-----↑					
68-425A		COVER,HOLE			
↑-----↑					
LA01-57-425A	2				

AUNA04

CAT. AUNA04-03

1995-04

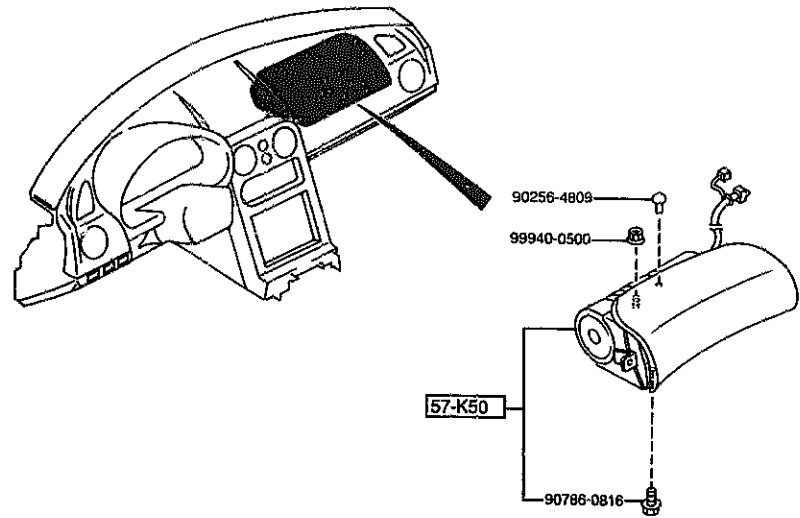
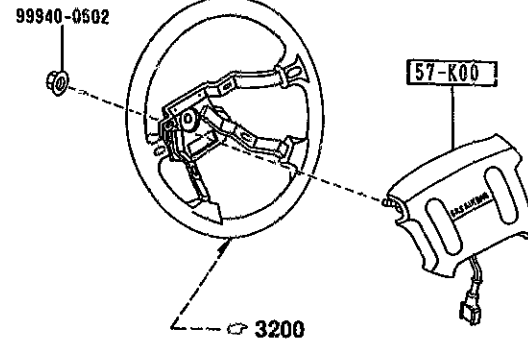
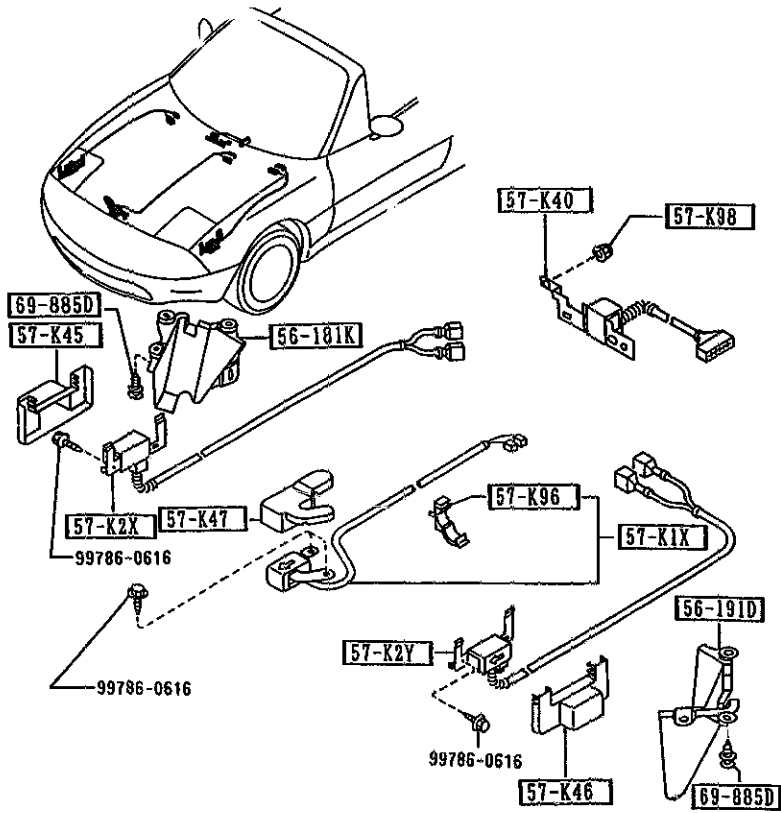

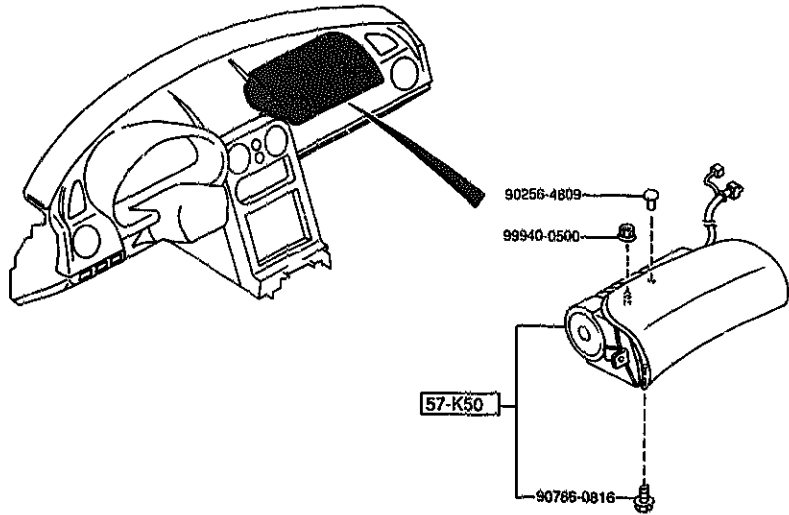
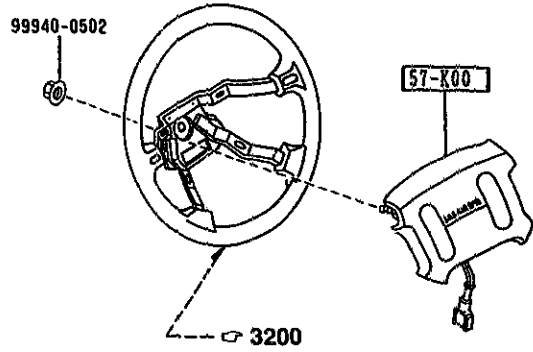

PART NO.	QTY	MODEL/RESTRICTION	MODEL/RESTRICTION	MODEL/RESTRICTION	FROM-TO
57-K96		CLIP			
FD01-57-K96	1				
57-K98		NUT			
FC66-57-K98	2				
69-885D		FASTENER			
NAD1-56-145	4	(A.LOCK BRAKE)			
NAD1-56-145	8	(W/O A.LOCK BRAKE)			

5800 -1 FRONT DOORS

5800 FRONT DOORS

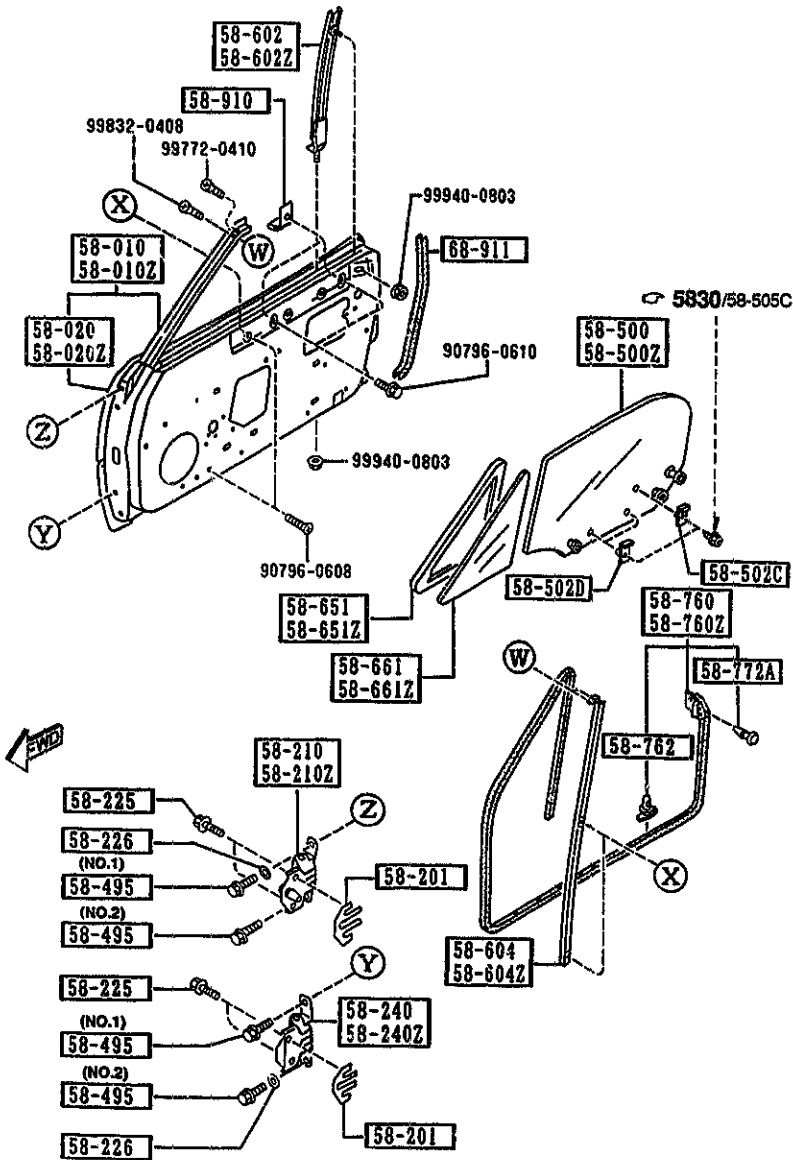

PART NO.	QTY	MODEL/RESTRICTION	MODEL/RESTRICTION	MODEL/RESTRICTION	FROM-TO
58-010		BODY(R), FRONT DOOR			
NAY3-58-02X	1				
58-010Z		BODY(L), FRONT DOOR			
NAY3-59-02X	1				
58-020		PANEL(R), OUT.-FRT DOOR			
NA52-58-030A	1				
58-020Z		PANEL(L), OUT.-FRT DOOR			
NA52-59-030A	1				
58-201		SHIM, HINGE-DOOR			
B092-58-201A	4				
58-210		HINGE(R), DOOR-UPPER			
FB01-58-210	1				
58-210Z		HINGE(L), DOOR-UPPER			
FB01-59-210	1				
58-225		BOLT, SETTING-HINGE LOWER			
B455-58-225	8				
58-226		WASHER, SETTING			
GJ21-58-226	4				
58-240		HINGE(R), DOOR-LOWER			
B156-58-240	1				
58-240Z		HINGE(L), DOOR-LOWER			
B156-59-240	1				
58-495		BOLT, SET			
BA54-58-225	4 (ILLUST. NO.1)				
S085-58-225	4 (ILLUST. NO.2)				
58-500		GLASS(R), DOOR-FRT			
NA01-58-510	1				

AUNA04

CAT. AUNA04-03

1995-04

5800 -2 FRONT DOORS

5800 FRONT DOORS

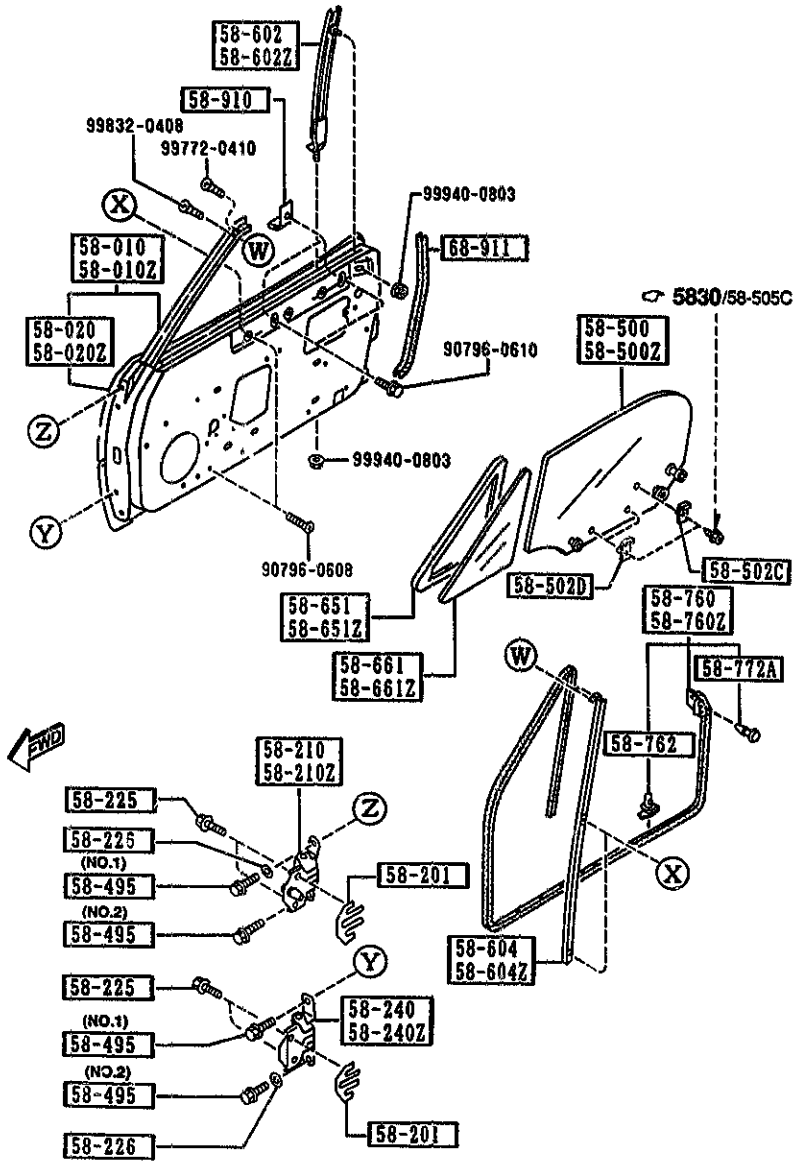

PART NO.	QTY	MODEL/RESTRICTION	MODEL/RESTRICTION	MODEL/RESTRICTION	FROM TO
58-500Z		GLASS(L), DOOR-FRT			
NA01-59-510	1				
58-502C		GRONMET, SCREW			
B235-58-502	2				
58-502D		GRONMET, SCREW-DOOR GLASS			
UB39-58-502A	4				
58-602		GUIDE*B*(R), GLASS			
NA01-58-603D	1				
58-602Z		GUIDE*B*(L), GLASS			
NA01-59-603D	1				
58-604		CHANNEL(R), DIVISION-DOOR			
NA01-58-604B	1				
58-604Z		CHANNEL(L), DIVISION-DOOR			
NA01-59-604B	1				
58-651		WEATHERSTRIP(R)			
NA01-58-651A	1				
58-651Z		WEATHERSTRIP(L)			
NA01-59-651A	1				
58-661		GLASS(R), VENTILATOR			
NA01-58-661	1				
58-661Z		GLASS(L), VENTILATOR			
NA01-59-661	1				
58-760		WEATHERSTRIP(R), DOOR			
NA01-58-760D A (NA01-58-760E)	1				-4701
*NA01-58-760E	1				4701-
58-760Z		WEATHERSTRIP(L), DOOR			
NA01-59-760D A (NA01-59-760E)	1				-4701
4701 NA3***-521312					

AUNA04

CAT. AUNA04-03

1995-04

2-K 9

5800 -3 * FRONT DOORS

5800 FRONT DOORS

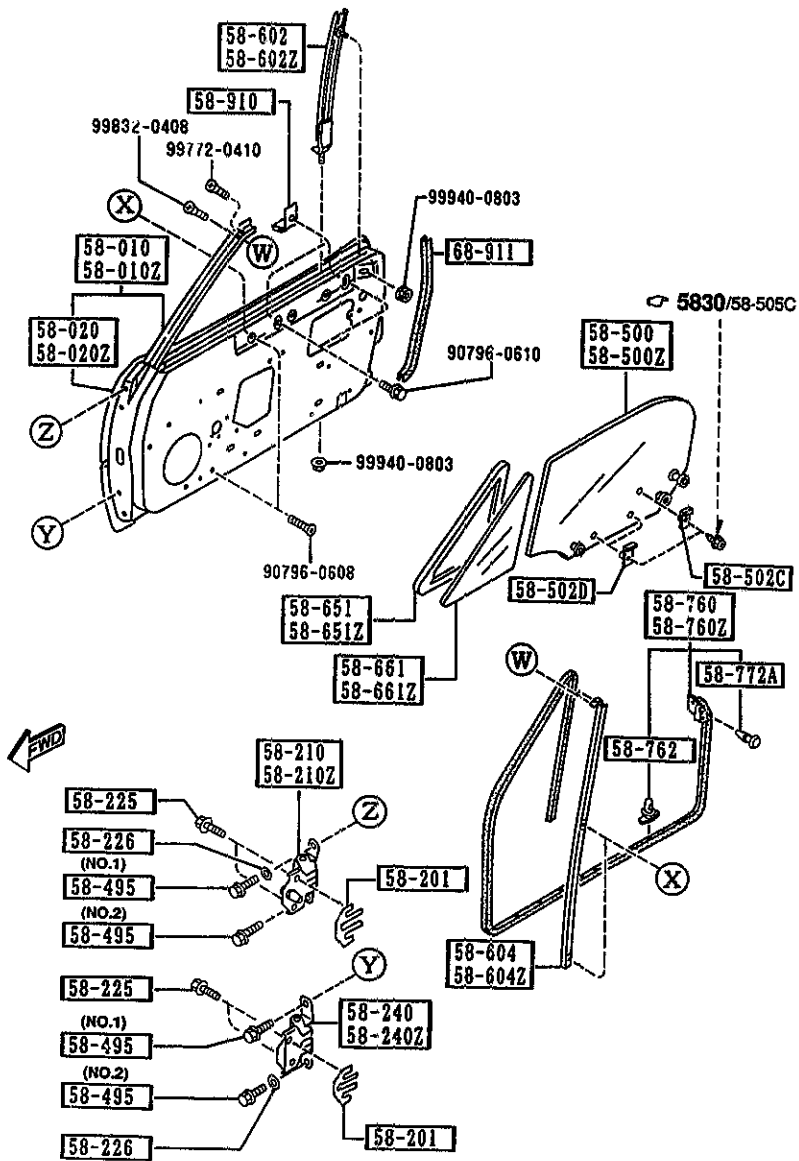

PART NO.	QTY	MODEL/RESTRICTION	MODEL/RESTRICTION	MODEL/RESTRICTION	FROM-TO
CONT'D NA01-59-760E	1				4701-
58-762		FASTENER			
6031-58-762	42				
58-772A		FASTENER			
1011-58-772	4				
58-910		STOPPER, GLASS			
H272-58-911	4				
68-911		WELT, SEAMING			
NA01-68-911	2				
00	INT-	NA3 NA5 NA4 NA6 BLACK			
4701 NA3***-521312					

AUNA04

CAT. AUNA04-03

1995-04

5830 FRONT DOOR MECHANISMS

5830 -1 FRONT DOOR MECHANISMS

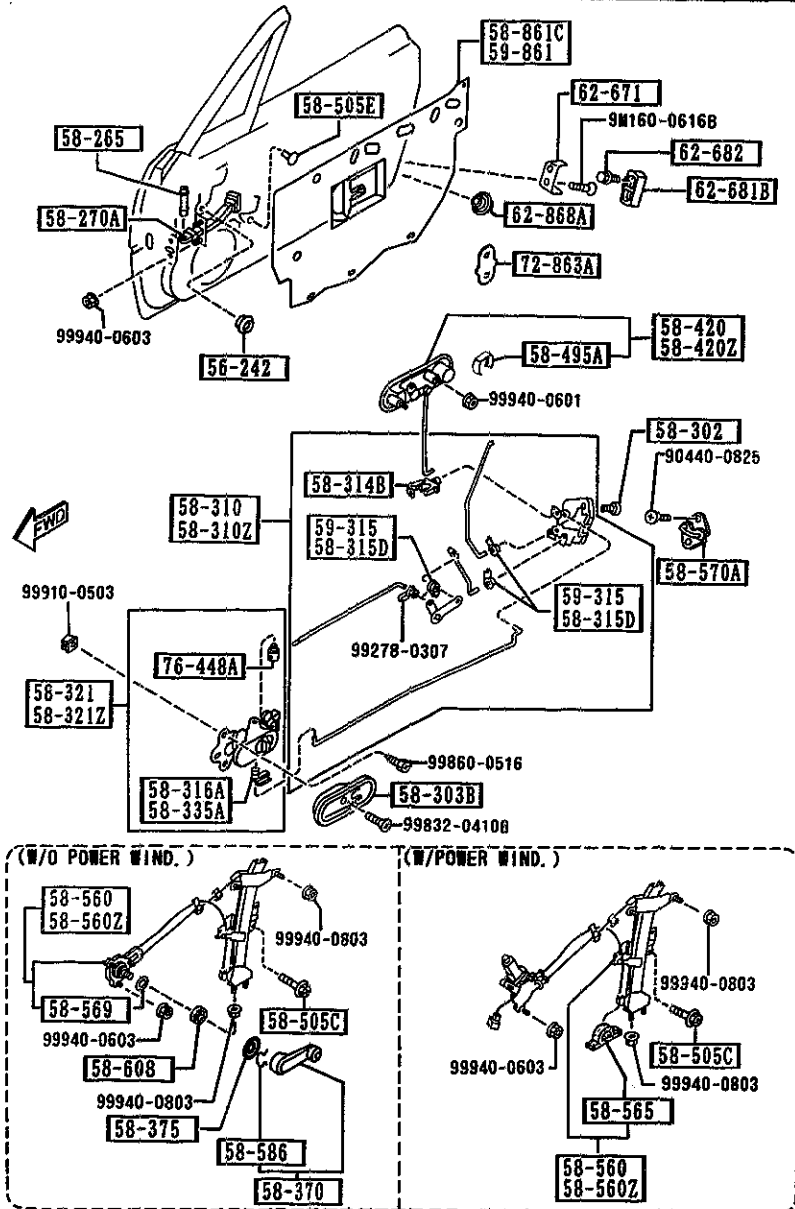

PART NO.	QTY	MODEL/RESTRICTION	MODEL/RESTRICTION	MODEL/RESTRICTION	FROM-TO
56-242		PLUG, DRAIN			
0118-56-242B	2				
58-265		PIN, CHECKER			
BC1D-58-265	2				
58-270A		CHECKER, DOOR			
NA01-58-270A	2				
58-302		SCREW, TAPPING-DOOR LOCK			
HG30-58-302A	6				
58-303B		COVER, INNER HANDLE			
NA01-58-303	2				
00	INT-	NA3 NA5 NA4 NA6 BLACK			
58-310		LOCK(R), DOOR			
NA01-58-310B	1				
58-310Z		LOCK(L), DOOR			
NA01-59-310B	1				
58-314B		JOINT			
H043-72-411	2				
58-315D		CLIP (R)			
G030-58-315	3	(IN SPITE OF (R), THIS PART IS APPLICABLE TO LH SIDE)			
58-316A		CLIP			
B001-59-335	1	(FOR RIGHT)			
58-321		HANDLE(R), INNER			
NA01-58-330A	1				
00	INT-	NA3 NA5 NA4 NA6 BLACK			
58-321Z		HANDLE(L), INNER			
NA01-59-330A	1				
00	INT-	NA3 NA5 NA4 NA6			

AUNA04

CAT. AUNA04-03

1995-04

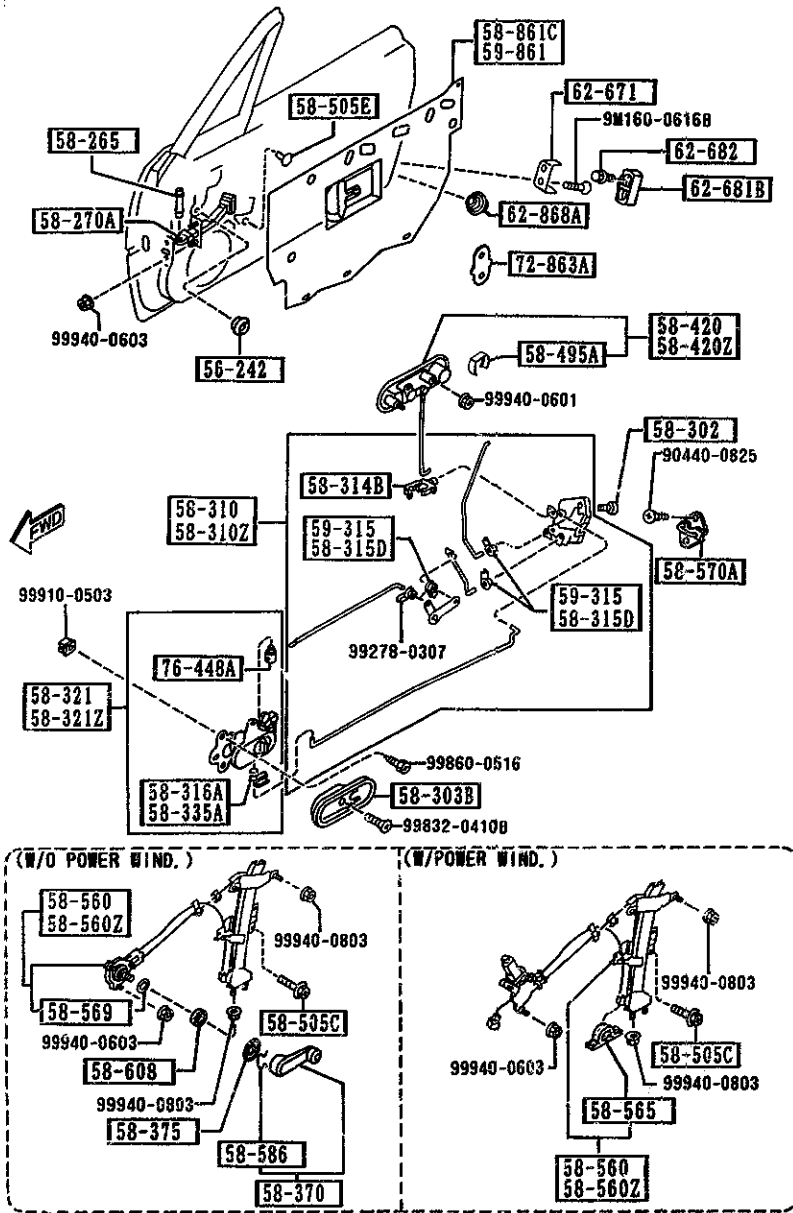

AUNA04

PART NO.	QTY	MODEL/RESTRICTION	MODEL/RESTRICTION	MODEL/RESTRICTION	FROM-TO
CONT'D					
		BLACK			
58-335A		CLIP			
FB01-58-335	1	(FOR LEFT)			
58-370		HANDLE,REGULATOR			
S084-58-580A	2	BASE, PKG-A, PKG-R, (W/O POWER WIND.)			
00	INT-	NA3 NA5 NA4 NA6 BLACK			
58-375		ESCUTCHEON			
B001-58-582A	2	BASE, PKG-A, PKG-R, (W/O POWER WIND.)			
00	INT-	NA3 NA5 NA4 NA6 BLACK			
58-420		HANDLE(R),OUT.			
NA01-58-410D	1				
58-420Z		HANDLE(L),OUT.			
NA01-59-410D	1				
58-495A		RETAINER,LOCK CYL.			
G211-58-495	2				
58-505C		SCREW,WINDOW REGULAT OR			
B092-58-505	6				
58-505E		CAP			
B092-58-355	2	BASE, PKG-A, PKG-R, (W/O POWER WIND.)			
58-560		REGULATOR(R),WINDOW			
NA02-58-560D AN(NA02-58-560E)	1				-3C01
NA01-58-560D A (NA01-58-560E)	1				-4419
NA02-58-560E A (NA02-58-560F)	1				3C01-4419
*NA02-58-560F A (NA02-58-560G)	1				4419-4608
*NA01-58-560E A (NA01-58-560F)	1				4419-4701
3C01 NA3***-507607 4419 NA3***-517950 4608 NA3***-519829 4701 NA3***-521312					

CAT. AUNA04-03

1995-04

5830 FRONT DOOR MECHANISMS

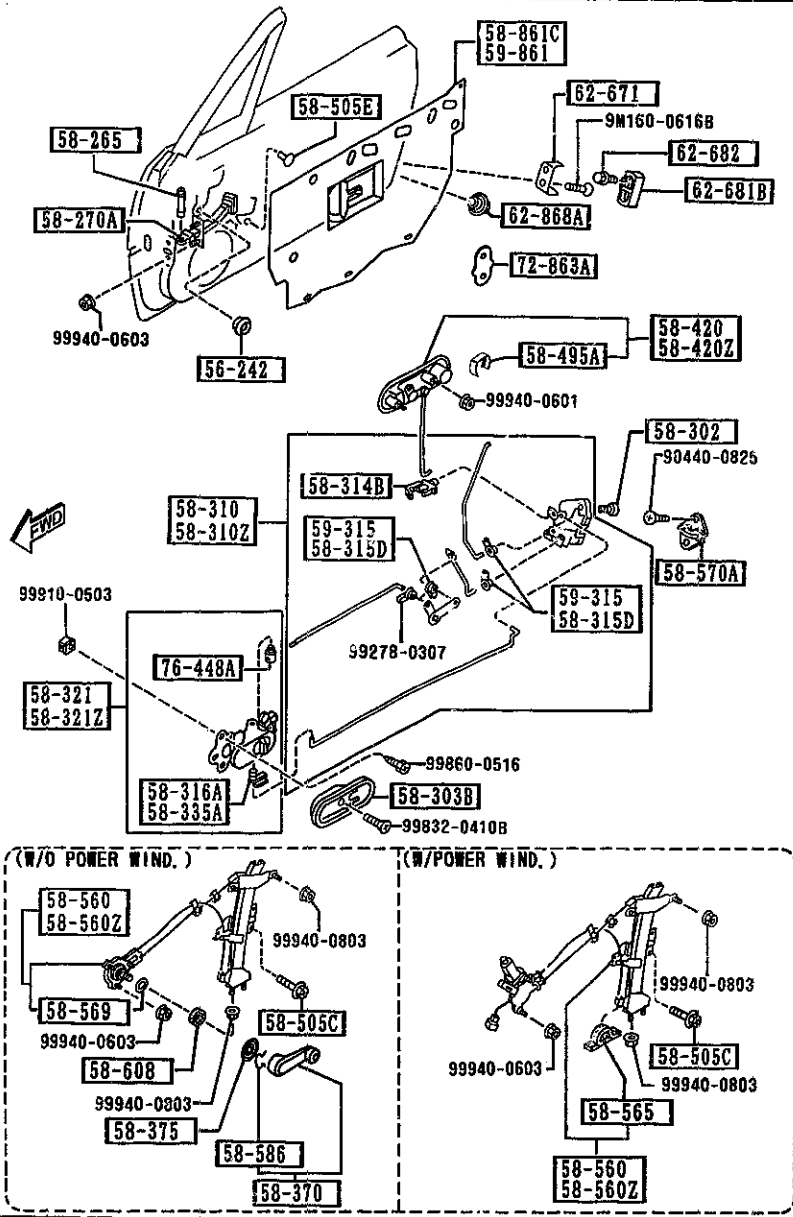

PART NO.	QTY	MODEL/RESTRICTION	MODEL/RESTRICTION	MODEL/RESTRICTION	FROM-TO
58-861C 59-861		SCREEN(R),FRONT DOOR			
NA01-58-861A	1	BASE, PKG-A, PKG-R, (W/O POWER WIND.)			
NA02-58-861A	1	PKG-B, PKG-C, RICO-O PT-PKG, (W/POWER WIND.)			
59-315		CLIP			
G030-59-315	3	(FOR RIGHT)			
59-861		SCREEN(L),FRONT DOOR			
NA01-59-861A	1	BASE, PKG-A, PKG-R, (W/O POWER WIND.)			
NA02-59-861A	1	PKG-B, PKG-C, RICO-O PT-PKG, (W/POWER WIND.)			
62-671		DOVETAIL,LIFT GATE			
S084-62-671	2				
62-681B		WEDGE,DOOR-FRONT			
NA01-62-681	2				
62-682		SCREW,WEDGE-LIFT GATE			
B216-62-682	4				
62-868A		COVER,HOLE-LIFT GATE			
B499-62-868	2				
72-863A		PAD			
H260-72-864B	2				
76-448A		CLIP			
G030-76-448	2				
3C01 NA3***-507607					

-3C01

AUNA04

CAT. AUNA04-03

1995-04

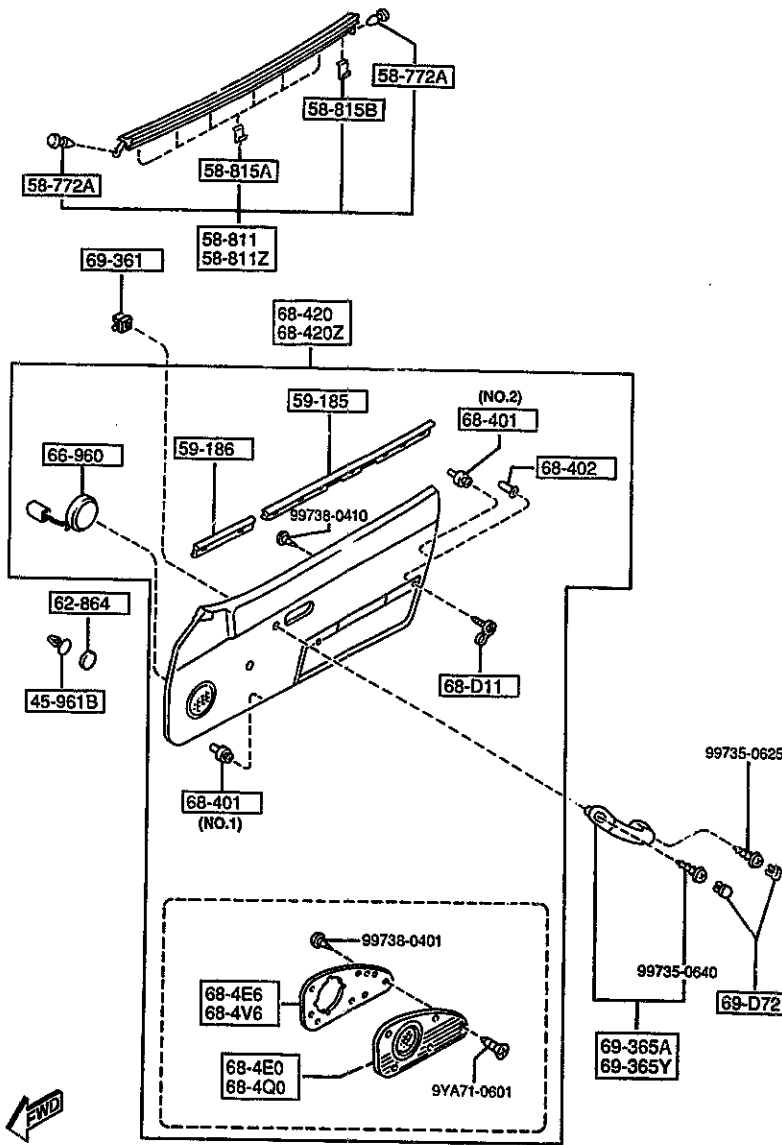

PART NO.	QTY	MODEL/RESTRICTION	MODEL/RESTRICTION	MODEL/RESTRICTION	FROM-TO
45-961B		CAP			
H002-45-961	2	BASE, (TDA-PLASTIC KICKPLATE)			
H002-45-961	2	OPT, (TDB-STAINLESS KICKPLATE)			-3A01
H002-45-961	4	OPT, (TDB-STAINLESS KICKPLATE)			3A01-
58-772A		FASTENER			
1011-58-772	4				
58-811		WEATHERSTRIP(R), OUT.			
NA01-58-810D	1				
58-811Z		WEATHERSTRIP(L), OUT.			
NA01-59-810D	1				
58-815A		CLIP, WEATHERSTRIP-OUTER			
NA01-58-815	12				
58-815B		CLIP 'A', WEATHERSTRIP-OUT			
B157-58-815	2				
59-185		WEATHERSTRIP NO.1			
NA01-58-821	2				
59-186		WEATHERSTRIP NO.2			
NA02-58-821	2				
62-864		TAPE, PROTECTOR-STOPPER			
G043-62-864A	2				
66-960		SPEAKER, LOUD-FRONT			
N019-66-960A	2	PKG-B-OPT, PKG-C-OPT (AM/FM, W/C.D., W/HEAD RR SPK. W/SENSORY SOUND)			
68-D11		CAP, SCREW			
B501-68-D11B	2				

3A01 NA3***-505179

AUNA04

CAT. AUNA04-03

1995-04

5840 -2 FRONT DOOR TRIMS & RELATED PARTS

5840 FRONT DOOR TRIMS & RELATED PARTS

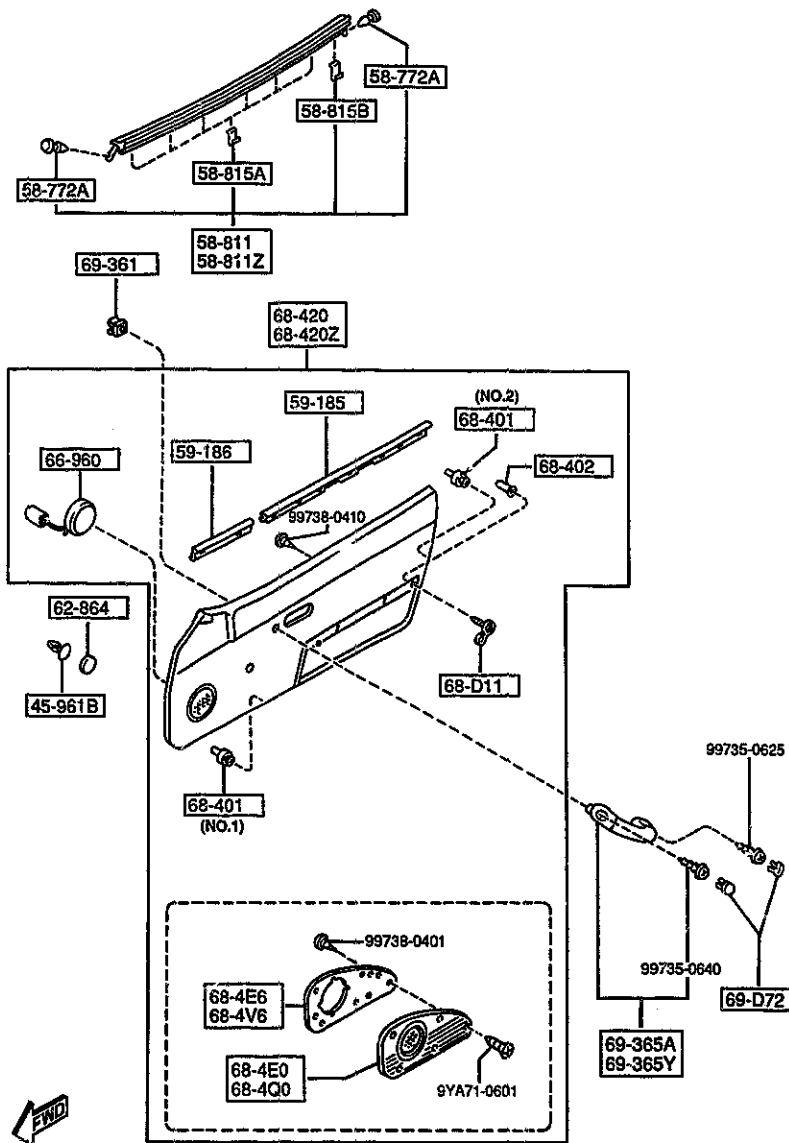

PART NO.	QTY	MODEL/RESTRICTION	MODEL/RESTRICTION	MODEL/RESTRICTION	FROM-TO
CONT'D					
00	INT-	NA3 BLACK			
67	INT-	NA4 NA5 TAN			
		PLATE(R),KICK-D.TRIM			
		68-4E0			
N020-68-4E1A	1	OPT, (TDB-STAINLESS KICKP LATE,W/ P.WIND.)			
		PLATE(R)			
		68-4E6			
N020-68-4E6	1	OPT, (TDB-STAINLESS KICKP LATE,W/ P.WIND.)			
		PLATE(L),KICK-D.TRIM			
		68-4Q0			
N020-68-4V1A	1	OPT, (TDB-STAINLESS KICKP LATE,W/ P.WIND.)			
		PLATE(L)			
		68-4V6			
N020-68-4V6	1	OPT, (TDB-STAINLESS KICKP LATE,W/ P.WIND.)			
		FASTENER,DOOR TRIM			
		68-401			
B100-68-401	16	(ILLUST. NO.1)			
W201-68-401	12	(ILLUST. NO.2)			
		GROMMET,SCREW			
		68-402			
B110-68-429	2				
		TRIM(R),DOOR			
		68-420			
N026-68-420B	1	OPT, (TDB-STAINLESS KICKP LATE,W/P. WIND,W/O S ENSORY SOUND.)			
00	INT-	NA3 BLACK			
80	INT-	NA5 BLACK/TAN			
N027-68-420B	1	OPT, (TDB-STAINLESS KICKP LATE,W/P. WIND,W/SEN SORY SOUND.)			
00	INT-	NA3 BLACK			
80	INT-	NA5 BLACK/TAN			
N028-68-420B	1	BASE, PKG-A, PKG-R, (TDA-PLASTIC KICKPLA TE,W/O P. WIND,W/O S			

AUNA04

CAT. AUNA04-83

1995-04

5840 FRONT DOOR TRIMS & RELATED PARTS

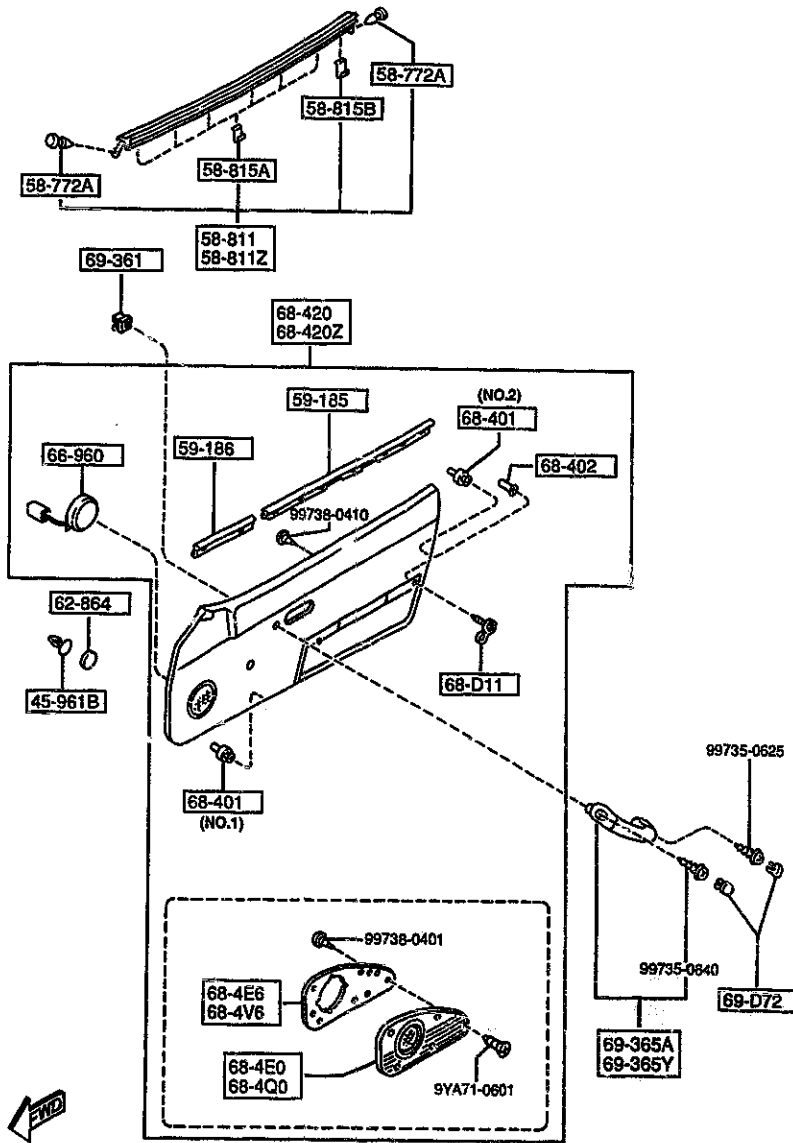

AUNA04

5840 -4 * FRONT DOOR TRIMS & RELATED PARTS

PART NO.	QTY	MODEL/RESTRICTION	MODEL/RESTRICTION	MODEL/RESTRICTION	FROM-TO
CONT'D					
00	INT-	NA3 BLACK			
80	INT-	NA5 BLACK/TAN			
N030-68-450B	1	PKG-B, PKG-C, RICO-0 PT-PKG, (TDA-PLASTIC KICKPLA TE,W/P. WIND,W/O SEN SDRY SOUND.)			
00	INT-	NA3 BLACK			
80	INT-	NA5 BLACK/TAN			
N031-68-450B	1	PKG-B-OPT, PKG-C-OPT (TDA-PLASTIC KICKPLA TE,W/P. WIND,W/SENSO RY SOUND.)			
00	INT-	NA3 BLACK			
80	INT-	NA5 BLACK/TAN			
69-D72		CAP,ASSIST GRIP			
N026-69-D72	2				
00	INT-	NA3 NA5 NA4 NA6 BLACK			
69-361		GROMMET,SCREW			
8316-69-361	4				
69-365A		GRIP(R),ASSIST			
N026-69-D70	1				
00	INT-	NA3 NA5 NA4 NA6 BLACK			
69-365Y		GRIP(L),ASSIST			
N026-69-D90	1				
00	INT-	NA3 NA5 NA4 NA6 BLACK			

CAT. AUNA -03

1995-04

6100 HEATER

6100 -1 * HEATER

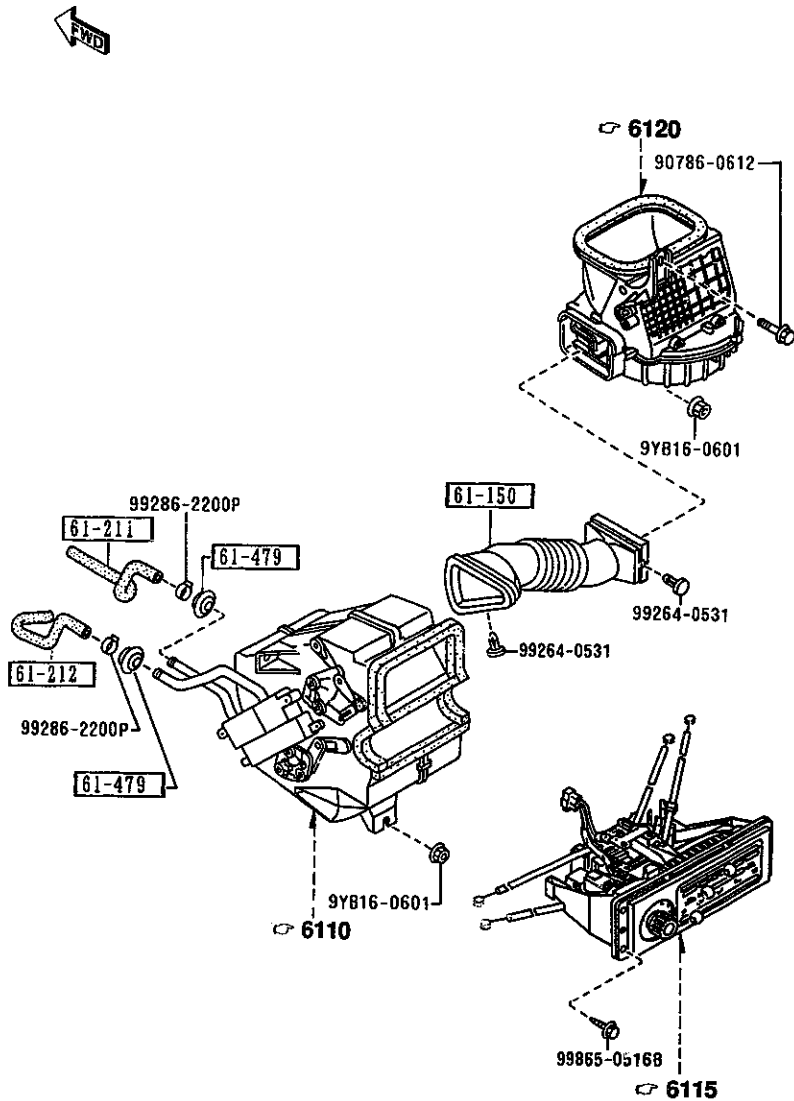

PART NO.	QTY	MODEL/RESTRICTION	MODEL/RESTRICTION	MODEL/RESTRICTION	FROM-TO
61-150 NA01-61-150A	1	DUCT,AIR			
61-211 NA75-61-211	1	HOSE NO.1,WATER			
61-212 NA75-61-212	1	HOSE NO.2,WATER			
61-479 8871-61-219A	2	GROMMET			

AUNA04

CAT. AUNA04-03

1995-04

6110 HEATER UNIT COMPONENTS

6110 -1 * HEATER UNIT COMPONENTS

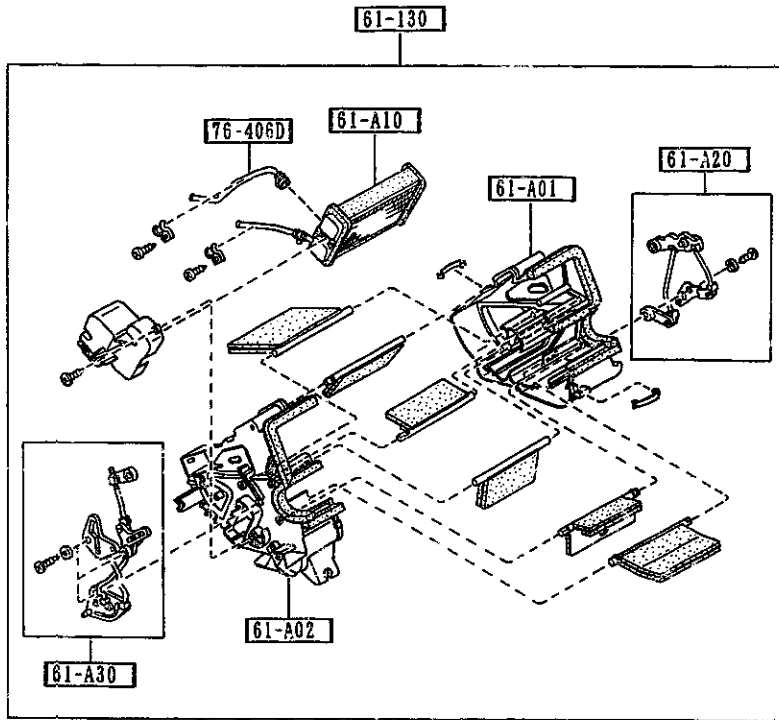

PART NO.	QTY	MODEL/RESTRICTION	MODEL/RESTRICTION	MODEL/RESTRICTION	FROM-TO
61-A01		CASE'A',HEATER UNIT			
NA01-61-A01	1				
61-A02		CASE'B',HEATER UNIT			
NA01-61-A02	1				
61-A10		CORE,HEATER UNIT			
NA75-61-A10	1				
61-A20		LINK SET,TEMP			
NA01-61-A20	1				
61-A30		LINK SET,MODE			
NA01-61-A30	1				
61-130		HEATER UNIT			
NA75-61-130	1				
76-406D		PIPE,HEATER UNIT			
NA75-61-A15	1				

AUNA04

CAT. AUNA04-03

1995-04

6115 HEATER CONTROLS COMPONENTS

6115 -1 * HEATER CONTROLS COMPONENTS

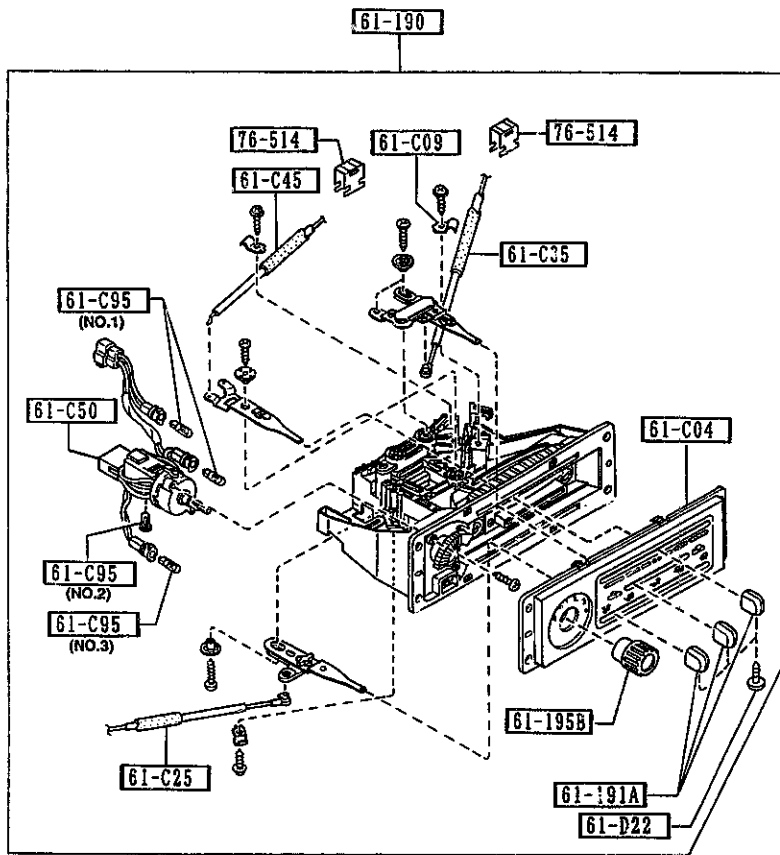

PART NO.	QTY	MODEL/RESTRICTION	MODEL/RESTRICTION	MODEL/RESTRICTION	FRONT TO
61-C04		PANEL, PLATE-MODE CONTROL			
NA01-61-C04A	1				
61-C09		CLIP, HEATER CONTROL			
H260-61-C09	1				
61-C25		WIRE, TEMP. CONTROL			
NA01-61-C25	1				
61-C35		WIRE, MODE CONTROL			
NA01-61-C35	1				
61-C45		WIRE, RECYCLE & FRESH			
NA75-61-C45	1				
61-C50		SWITCH, FAN-HEATER CONTROL			
NA01-61-C50	1				
61-C95		BULB, MODE CONTROL			
NA01-61-C95	2 (ILLUST. NO.1)				
NA02-61-C95	1 (ILLUST. NO.2)				
NA03-61-C95	1 (ILLUST. NO.3)				
61-D22		SCREW, RR HEATER UNIT			
NA01-61-D22	3				
61-190		CONTROL, HEATER			
NA75-61-190B	1				
61-191A		KNOB NO.1			
NA01-61-191	5				
61-195B		KNOB, FAN SWITCH			
NA01-61-195	1				
76-514		CLIP			
B001-76-526	2				

AUNA04

CAT. AUNA04-03

1995-04

6120 HEATER BLOWER COMPONENTS

6120 -1 * HEATER BLOWER COMPONENTS

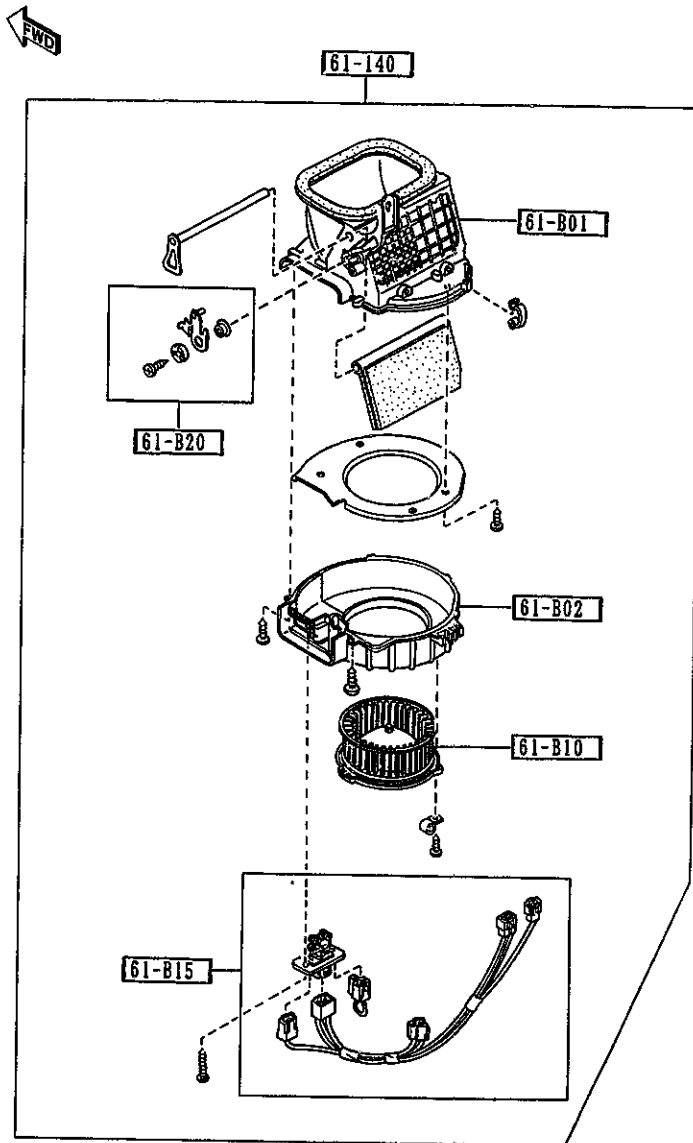

PART NO.	QTY	MODEL/RESTRICTION	MODEL/RESTRICTION	MODEL/RESTRICTION	FROM-TO
61-B01		CASE 'A', BLOWER UNIT			
NA75-61-B01	1				
61-B02		CASE 'B', BLOWER UNIT			
NA01-61-B02	1				
61-B10		MOTOR, FAN-BLOWER UNIT			
NA01-61-B10	1				
61-B15		RESISTOR, BLOWER UNIT			
NA01-61-B15	1				
61-B20		LINK, RECYCLE & FRESH			
NA01-61-B20	1				
61-140		BLOWER UNIT			
NA75-61-140	1				

AUNA04

CAT. AUNA04-03

1995-04

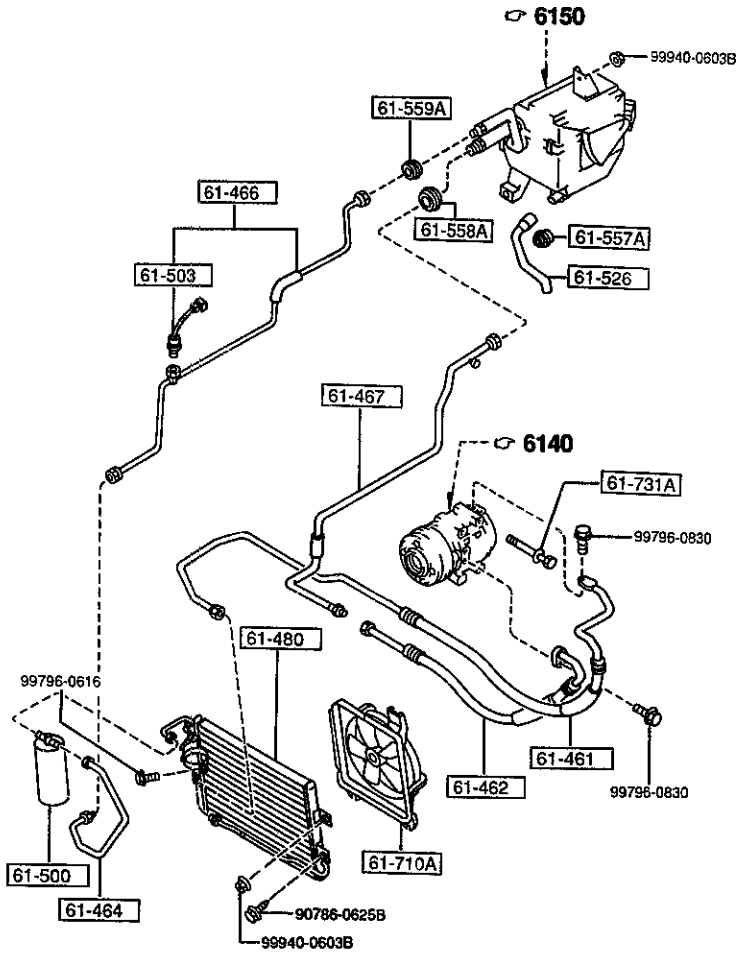

AUNA04

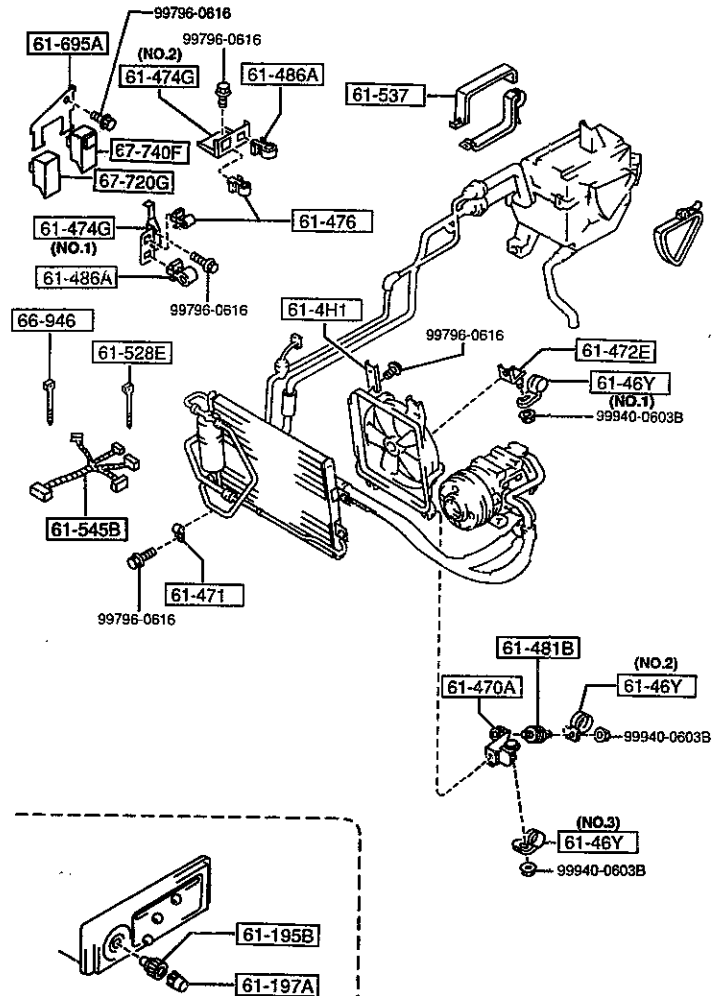

AUNA04

6130 AIR CONDITIONER
(HOSE & CONDENSER)

(1/2)

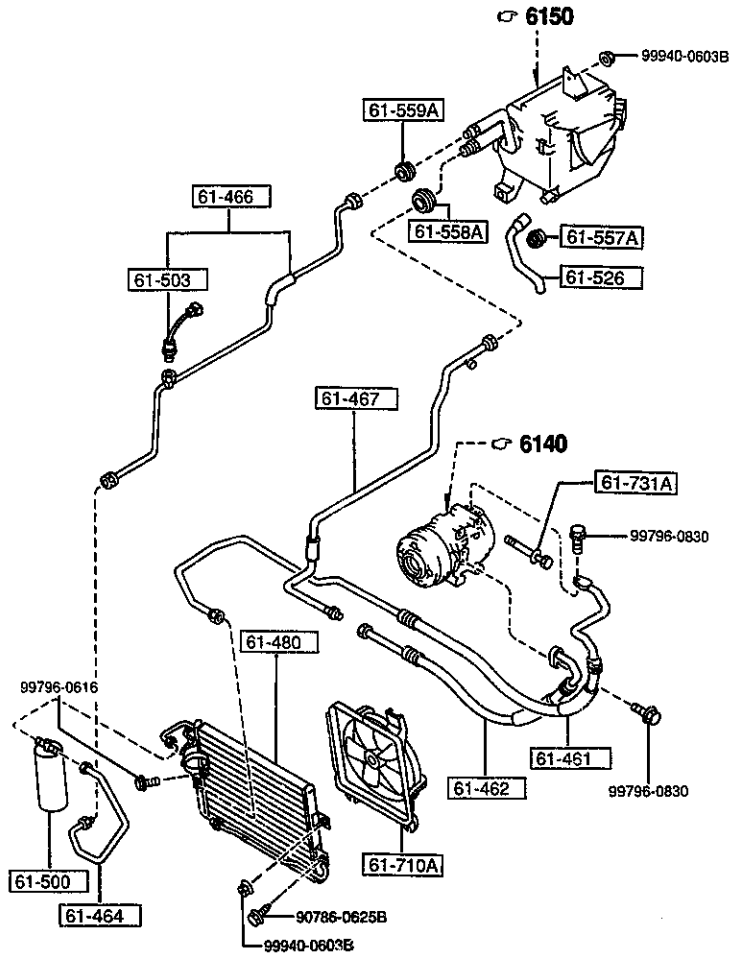

6130 -1 AIR CONDITIONER

PART NO.	QTY	MODEL/RESTRICTION	MODEL/RESTRICTION	MODEL/RESTRICTION	FROM-TO
61-195B		KNOB,FAN SWITCH			
NA01-61-193	1				
61-197A		KNOB,AIR CON.			
NA01-61-197	1				
61-4H1		BRACKET,HOSE			
NA01-61-4H1	1	(A)			
61-46Y		CLIP,PIPE			
BR71-61-46Y	1	(A)			
BR76-61-46Y	1	(ILLUST. NO.1)			
NA01-61-46YC	1	(A)			
61-461		HOSE,FLEXIBLE-HIGH			
NA75-61-461	1	(A)			
61-462		HOSE,FLEXIBLE-LOW			
NA75-61-462	1	(A)			
61-464		PIPE NO.2,COOLER			
NA75-61-467	1	(A)			
61-466		PIPE NO.4,COOLER			
NA75-61-46XA	1	(A)			
61-467		PIPE NO.5,COOLER			
NA75-61-46B	1	(A)			
61-470A		BRACKET,HOSE			
NA02-61-471A	1	(A)			
61-471		CLIP,PIPE			
BF67-61-471	1	(A)			

AUNA04

CAT. AUNA04-03

1995-04

2-H11

6130 AIR CONDITIONER
(BRACKET & CLIP)

(2/2)

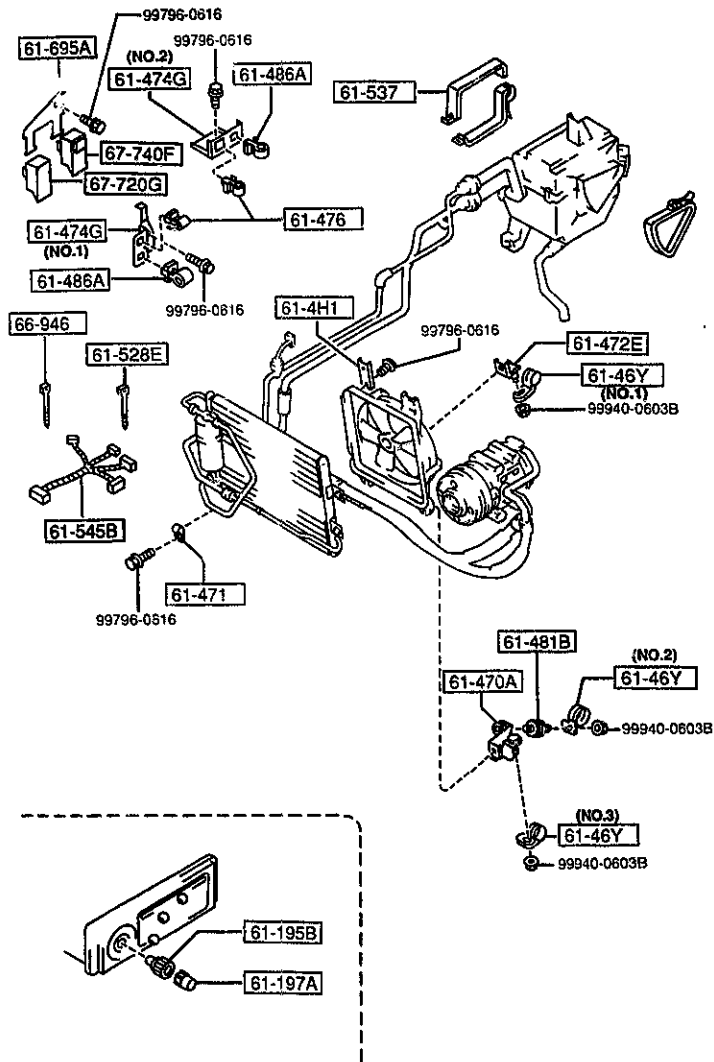

PART NO.	QTY	MODEL/RESTRICTION	MODEL/RESTRICTION	MODEL/RESTRICTION	FROM-TO
61-472E	1	BRACKET,CLAMP			
NA01-61-472		(A)			
61-474G	1	BRACKET,PIPE			
NA01-61-474		(A)			
NA02-61-474A	1	(A)			
61-476	2	CLIP			
NA02-61-476		(A)			
61-480	1	CONDENSER			
NA75-61-480		(A)			
61-481B	1	RUBBER,INSULATOR			
FC20-61-481		(A)			
61-486A	2	CLIP			
UB39-61-486A					
61-500	1	TANK,LIQUID			
NA75-61-500		(A)			
61-503	1	SW.,PRESSURE-LIQUID TANK			
GB6H-61-503		(G)			
61-526	1	HOSE,DRAIN			
NA01-61-526		(A)			
61-528E	1	BAND			
NA01-61-435		(G)			
61-537	1	PLATE NO.3,SEAL			
NA01-61-529		(A)			

(HOSE & CONDENSER)

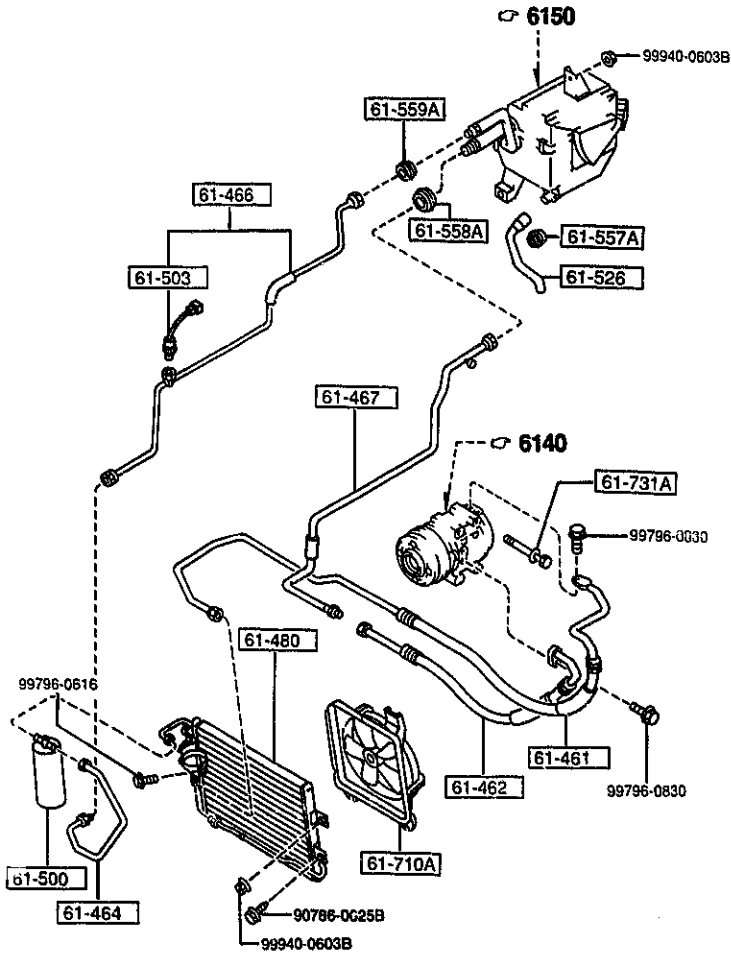

PART NO.	QTY	MODEL/RESTRICTION	MODEL/RESTRICTION	MODEL/RESTRICTION	FROM-TO
61-545B NA75-61-545A	1	HARNES, WIRE (A)			
61-557A FB04-61-557	1	GROMMET (A)			
61-558A BF67-61-558	1	GROMMET (A)			
61-559A BF67-61-559	1	GROMMET (A)			
61-695A NA75-61-695	1	BRACKET, RELAY (A)			
61-710A NA01-61-710	1	FAN, CONDENSER (A)			
61-731A B111-61-731	4	BOLT, AIR CON.			
66-946 NA02-61-435	1	BAND (A)			
67-720G EE12-67-720	1	RELAY, TRANSFER			
67-740F H450-67-740	1	CONTROL, COOLANT FAN			

6140 COMPRESSOR COMPONENTS (AIR CONDITIONER)

6140 -1 COMPRESSOR COMPONENTS (AIR CONDITIONER)

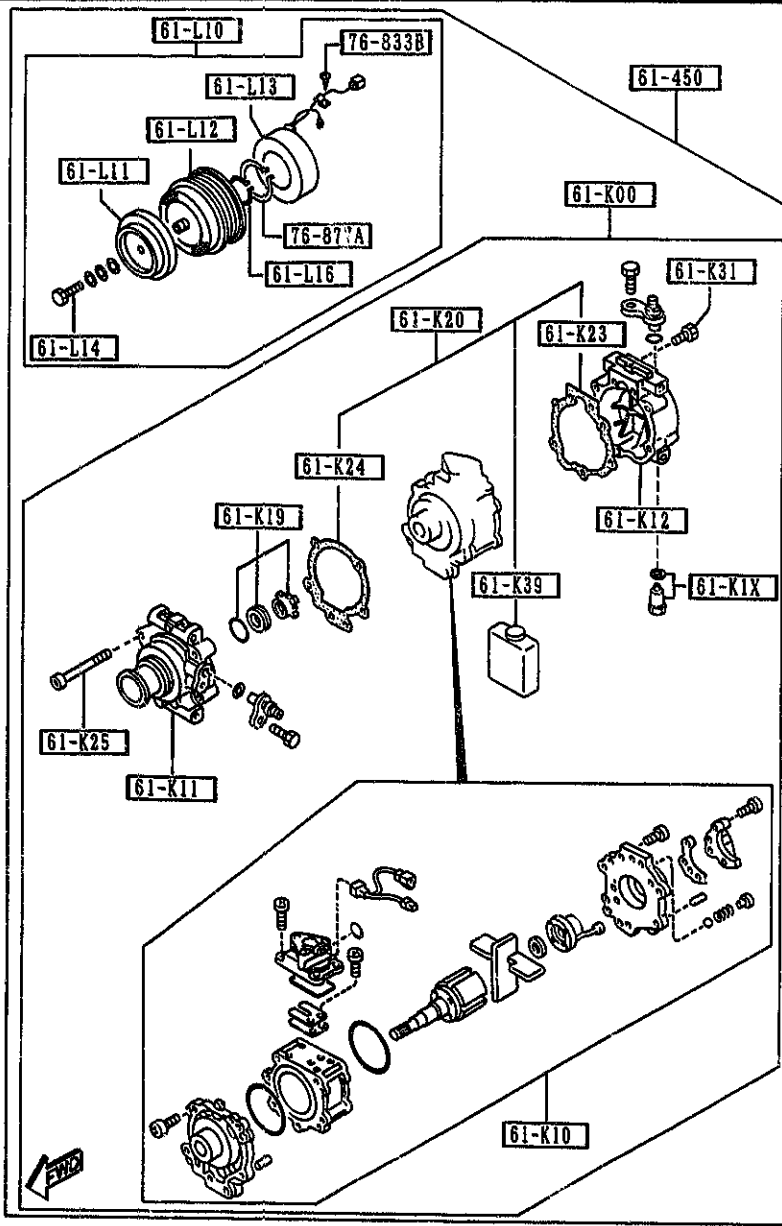

PART NO.	QTY	MODEL/RESTRICTION	MODEL/RESTRICTION	MODEL/RESTRICTION	FROM-TO
61-K00 NA75-61-K00	1	COMPRESSOR,AIR CON. (A)			
61-K1X NA75-61-K1X	1	VALVE,RELIEF (A)			
61-K10 NA75-61-K10	1	SHAFT,CYL -COMPRESSOR (A)			
61-K11 NA75-61-K11	1	HEAD,CYL.-COMPRESSOR (A)			
61-K12 NA75-61-K12	1	HEAD,CYL.-COMPRESSOR (A)			
61-K19 NA75-61-K19	1	SEAL,SHAFT-COMPR. (A)			
61-K20 NA75-61-K2X	1	GASKET KIT,COMPRESSOR (A)			
61-K23 NA75-61-X23	1	PLUG,COMPRESSOR			
61-K24 NA02-61-K24	1	GASKET,COMPRESSOR (A)			
61-K25 F065-61-K25	5	BOLT,COMPRESSOR-AIR CON.			
61-K31 F065-61-K31	2	BOLT,COMPRESSOR			
61-K39 NA75-71-K39	1	OIL,COMPRESSOR			

AUNA04

CAT. AUNA04-03

1995-04

2-K11

6140 COMPRESSOR COMPONENTS (AIR CONDITIONER)

6140 -2 X COMPRESSOR COMPONENTS (AIR CONDITIONER)

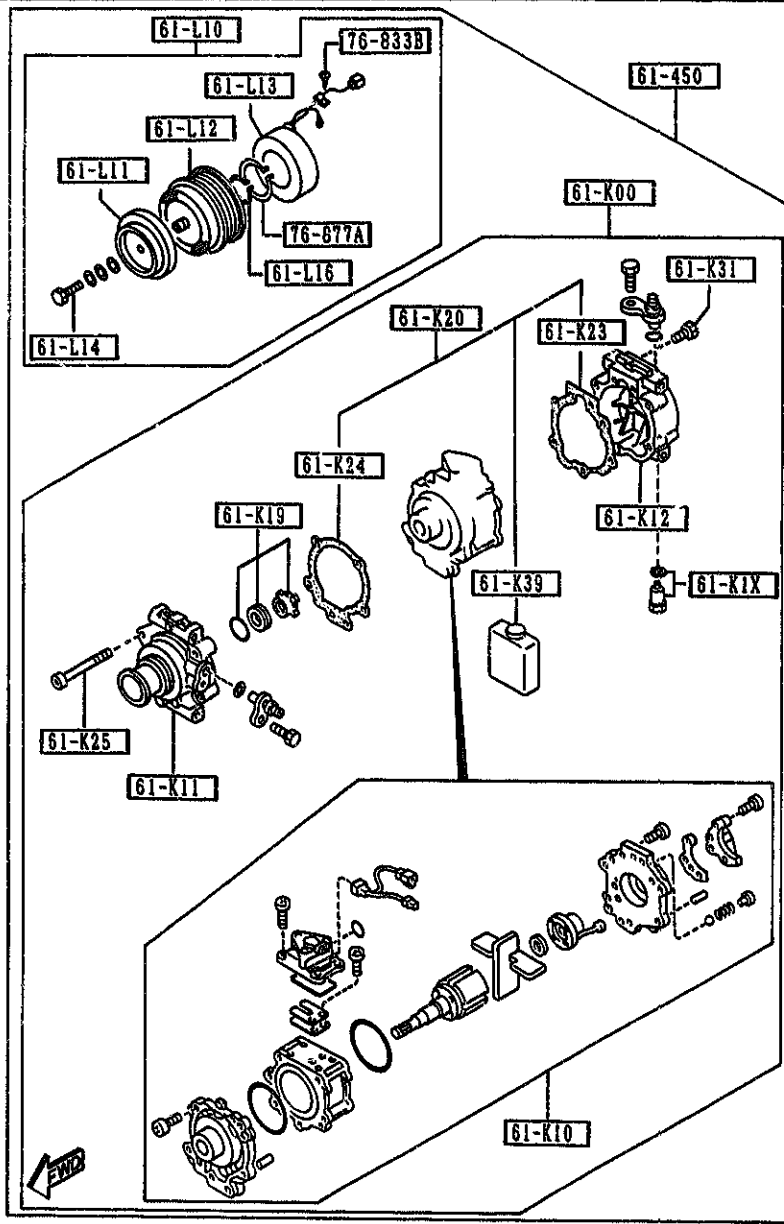

PART NO.	QTY	MODEL/RESTRICTION	MODEL/RESTRICTION	MODEL/RESTRICTION	FROM-TO
61-L10	1	CLUTCH,MAGNET			
NA75-61-L10		(A)			
61-L11	1	ARMATURE,MAGNETIC CL			
NA75-61-L11		UTCH			
(A)					
61-L12	1	PULLEY,MAGNET CLUTCH			
NA75-61-L12		(A)			
61-L13	1	COIL,FIELD-MAGNET CL			
NA75-61-L13		UTCH			
(A)					
61-L14	1	BOLT,MAGNET CLUTCH			
F065-61-L14					
61-L16	1	RING,SNAP-MAGNET CL			
F065-61-L16		TCH			
61-450	1	COMPRESSOR			
NA75-61-450		(A)			
76-833B	1	WASHER			
B001-76-734					
76-877A	1	RING,SNAP			
B001-76-725					

AUNA04

CAT. AUNA04-03

1995-04

6150 COOLING UNIT (AIR CONDITIONER)

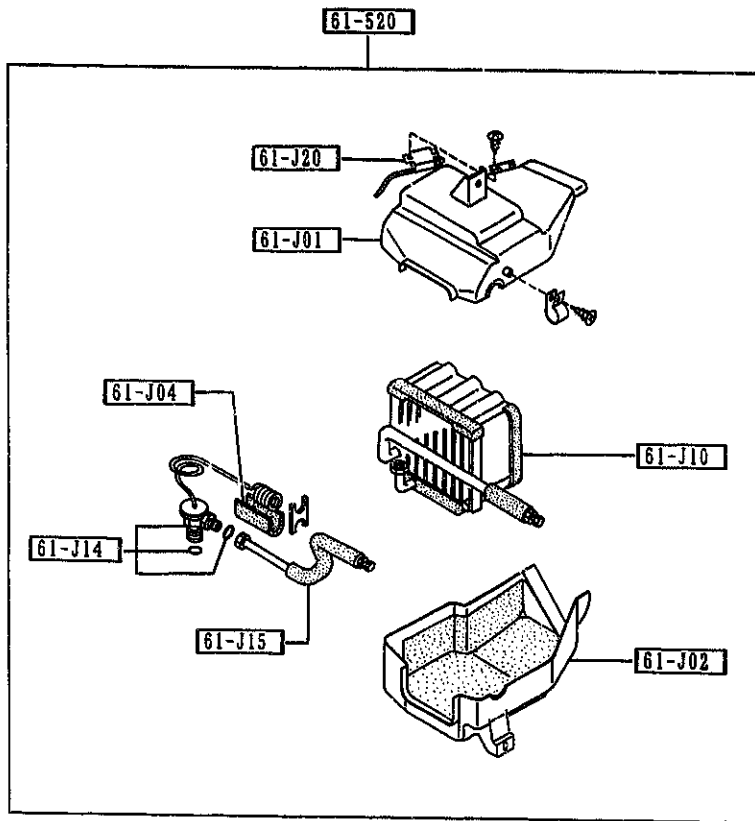

6150 -1 * COOLING UNIT (AIR CONDITIONER)

PART NO.	QTY	MODEL/RESTRICTION	MODEL/RESTRICTION	MODEL/RESTRICTION	FROM-TO
61-J01 NA01-61-J01A	1	CASE 'A', COOLING UNIT (A)			
61-J02 NA01-61-J02A	1	CASE 'B', COOLING UNIT (A)			
61-J04 NA01-61-J04	1	SEAL, COOLING UNIT (A)			
61-J10 NA01-61-J10A	1	EVAPORATOR (A)			
61-J14 NA75-61-J14	1	VALVE, EXPANSION (A)			
61-J15 NA01-61-J15	1	PIPE, COOLING UNIT (A)			
61-J20 NA01-61-J20	1	THERMOSTAT, COOLING UNIT (A)			
61-520 NA75-61-520B	1	UNIT, COOLING (A)			



6300 WINDOW GLASSES

6300 -1 * WINDOW GLASSES

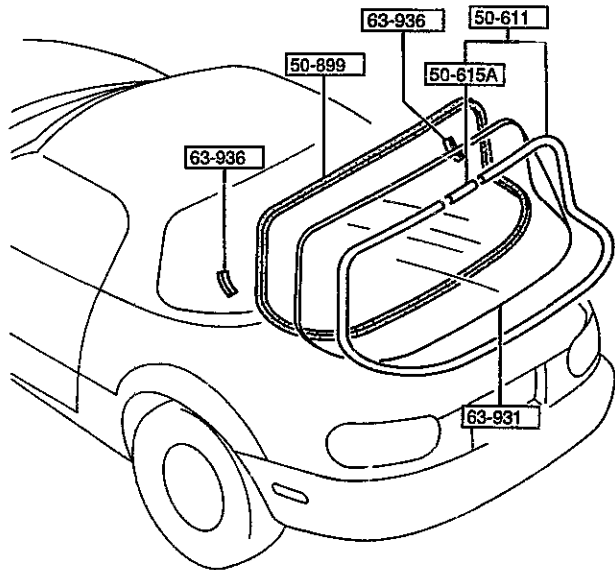
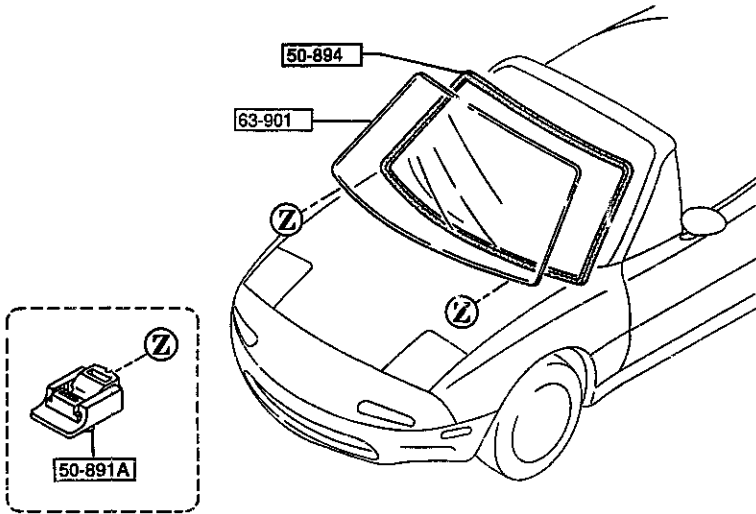

PART NO.	QTY	MODEL/RESTRICTION	MODEL/RESTRICTION	MODEL/RESTRICTION	FROM-TO
50-611 MAY1-63-930	1	MOULD,RR.WINDOW (W/DETACHABLE HARD TOP)			
50-615A MAY1-63-934	1	JOINT,BACK WINDOW MOLD (W/DETACHABLE HARD TOP)			
50-891A EA01-50-891 AN(EA01-50-891A)	2	SPACER,WINDOW WHITE			-4401
EA01-50-891A	2	WHITE			4401-
50-894 MAY1-50-894A	1	DAM,FRONT-WIND.			
50-899 MAY1-63-895	1	DAM,REAR-WIND. (W/DETACHABLE HARD TOP)			
63-901 MAY1-63-901	1	GLASS,WINDSHIELD			
63-931 MAY1-63-931	1	GLASS,BACK WINDOW (W/DETACHABLE HARD TOP)			
63-936 MAY1-63-936A	2	PRTR,BACK WINDOW-UP PER (W/DETACHABLE HARD TOP)			-4301

4301 NA3***-514672
4401 NA3***-517818

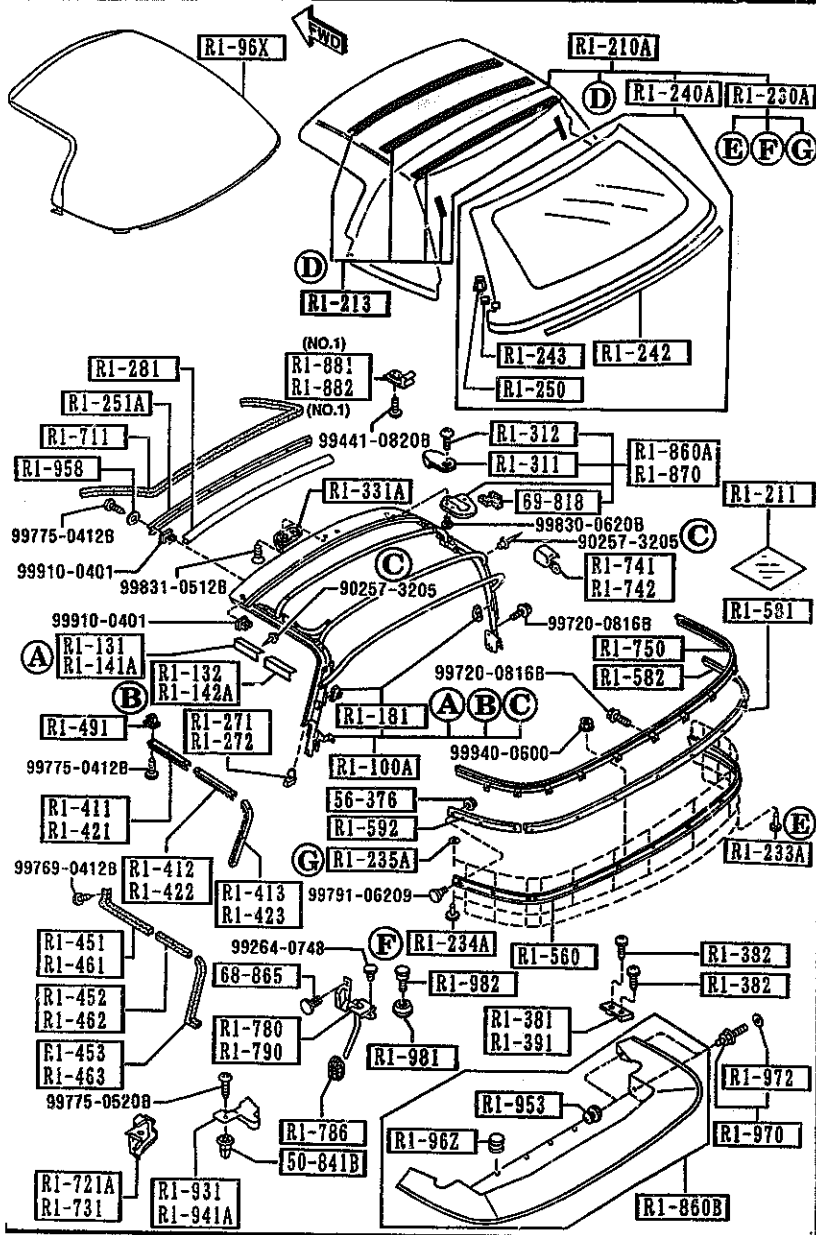

PART NO.	QTY	MODEL/RESTRICTION	MODEL/RESTRICTION	MODEL/RESTRICTION	FROM-TO
RI-100A		LINK,SOFT TOP			
NA01-RI-100E	1				
RI-131		PROTECTOR'A'(R),LINK			
NA01-RI-131	1				
RI-132		PROTECTOR'B'(R),LINK			
NA01-RI-132	1				
RI-141A		PROTECTOR'A'(L),LINK			
NA01-RI-141	1				
RI-142A		PROTECTOR'B'(L),LINK			
NA01-RI-142	1				
RI-181		STOPPER,LINK-HOOD			
NA01-RI-181	2				
RI-210A		FABRIC, TOP-SOFT TOP			
NA01-RI-210H	1				-3A01
AN(NA01-RI-210J)					
NA02-RI-210B	1				-3A01
AN(NA02-RI-210C)					
NA01-RI-210J	1	BASE, PKG-A, PKG-B, PKG-R, (BLACK)			3A01-
NA02-RI-210C	1	PKG-C, (TAN)			3A01-
RI-211		CLOTH,REPAIR-TOP			
NAV1-RI-211	1	BASE, PKG-A, PKG-P, PKG-R, (BLACK)			
NAV2-RI-211	1	PKG-C, (TAN)			
RI-213		CLOTH'C',TOP			
NA02-RI-213	1	PKG-C, (TAN)			
RI-230A		FASTENER SET,TOP CLOTH			
NA01-RI-230	1				

3A01 NA3***-505179

(W/DETACHABLE HARDTOP)

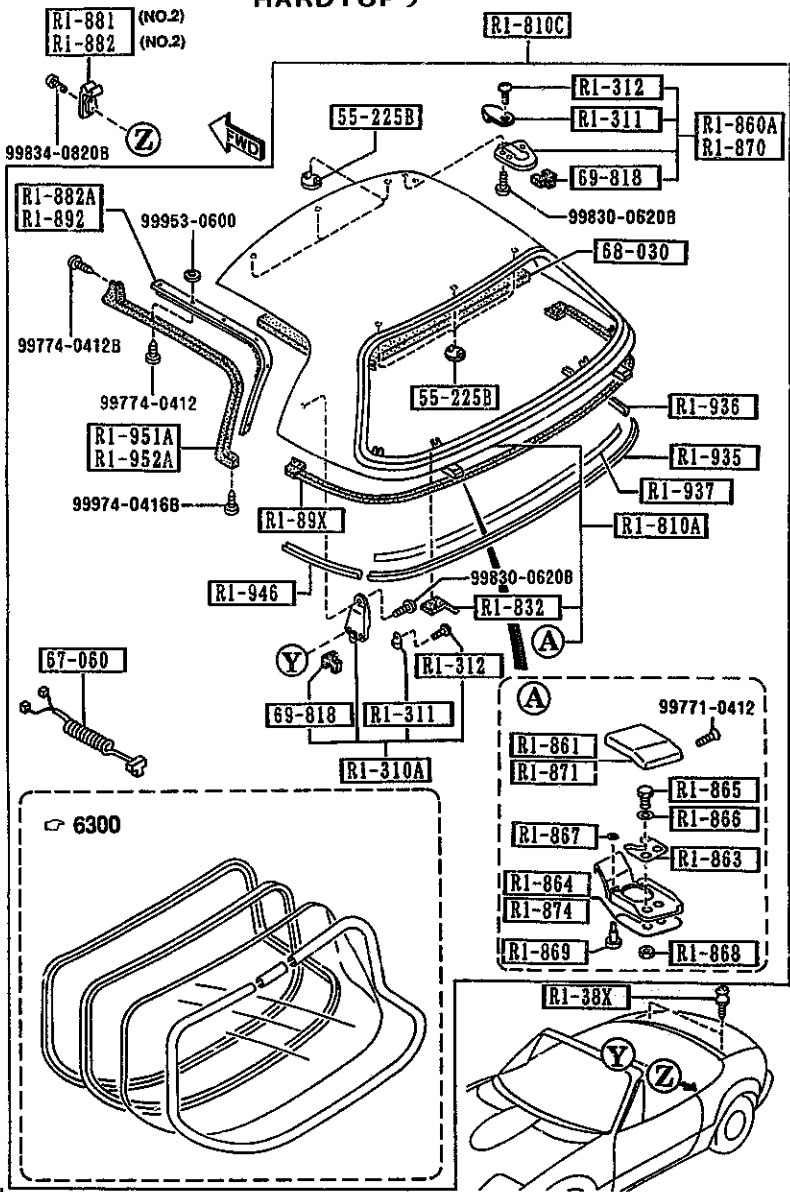

PART NO.	QTY	MODEL/RESTRICTION	MODEL/RESTRICTION	MODEL/RESTRICTION	FROM-TO
RI-233A		FASTENER,RAIN RAIL-SIDE			
NA01-RI-233	8				
RI-234A		FASTENER,RAIN RAIL-REAR			
NA01-RI-234	7				
RI-235A		WASHER,FASTENER-RAIN RAIL			
NA01-RI-235	15				
RI-240A		WINDOW,BACK-D. TOP			
NAV1-RI-240E		BLACK			-3C15
AN(NAV1-RI-240F)	1				
NAV2-RI-240B		TAN			-3C15
AN(NAV2-RI-240C)	1				
NAV1-RI-240F	1	BASE, PKG-A, PKG-B, PKG-R, (BLACK)			3C15-
NAV2-RI-240C	1	PKG-C, (TAN)			3C15-
RI-242		TAPE,SEAL-RAIN RAIL			
NAV1-RI-242	1				
RI-243		STOPPER,ZIPPER-BACK WINDOW			
NAV1-RI-243	2				
RI-250		HEAD,ZIPPER-BACK WINDOW			
NA01-RI-250B	1				
RI-251A		PLATE(FRT),SET-ROOF PANEL			
NA01-RI-291	1				
RI-271		CLIP(R),FORM PLATE			
NA01-RI-271	1				
RI-272		CLIP(L),FORM PLATE			
NA01-RI-272	1				
RI-281		WELT,SEAMING-SOFT TOP			
NA01-RI-281	1				
RI-310A		LOCK,DETACHABLE TOP			

3C15 NA3***-508712

6330 SUNROOF
(W/DETACHABLE HARDTOP)

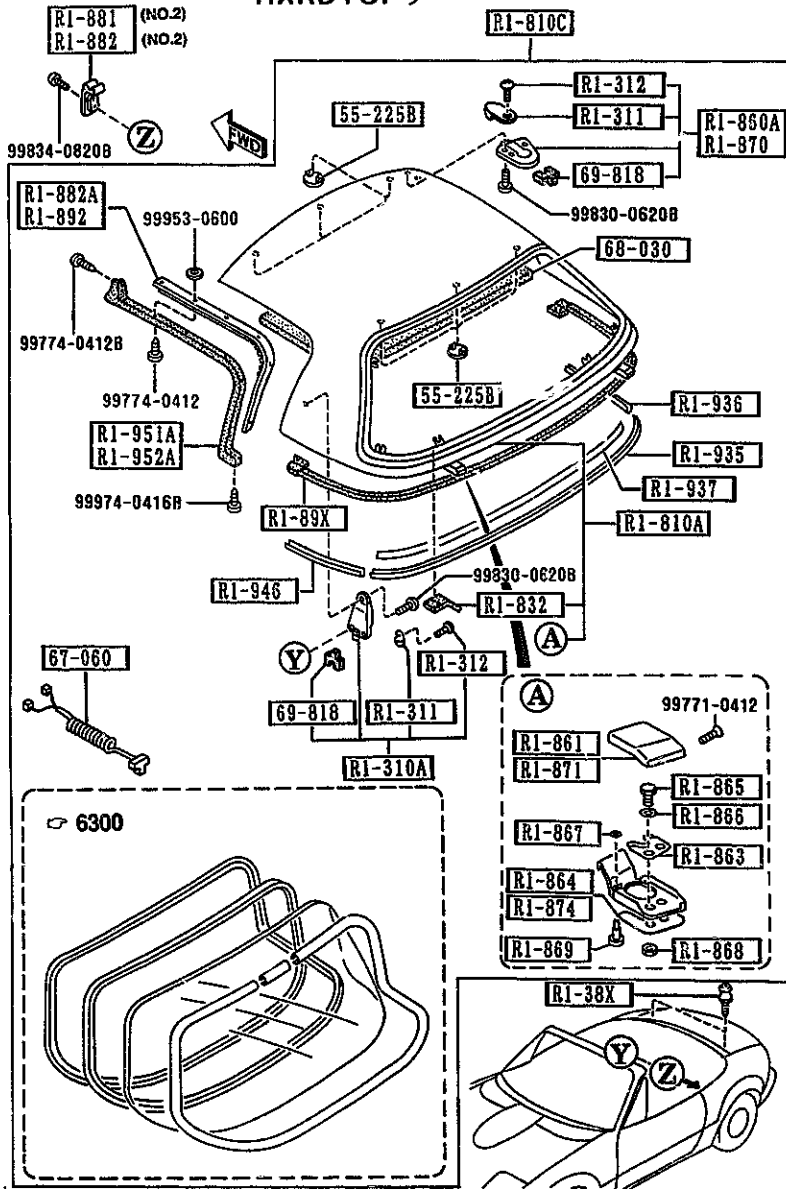

PART NO.	QTY	MODEL/RESTRICTION	MODEL/RESTRICTION	MODEL/RESTRICTION	FROM-TO
R1-422		RETAINER'B'(L),WTHST P			
NA01-R1-472	1				
R1-423		RETAINER'C'(L),WTHST P			
NA01-R1-473	1				
R1-451		WTHSTP NO.1(R),LINK			
NA01-R1-411B	1				
R1-452		WTHSTP NO.2(R),LINK			
NA01-R1-412B	1				
R1-453		WTHSTP NO.3(R),LINK			
NA01-R1-413B	1				
R1-461		WTHSTP NO.1(L),LINK			
NA01-R1-421B	1				
R1-462		WTHSTP NO.2(L),LINK			
NA01-R1-422B	1				
R1-463		WTHSTP NO.3(L),LINK			
NA01-R1-423B	1				
R1-491		GROMMET,SCREW-RETAINER			
NA01-R1-491	16				
R1-560		RAIL,RAIN-SOFT TOP REAR			
NA01-R1-560C	1				
R1-581		PLATE(C),SET-TOP FABRIC			
NA01-R1-581B	1				
R1-582		PLATE(R),SET-TOP FABRIC			
NA01-R1-582A	1				
R1-592		PLATE(L),SET-TOP FABRIC			
NA01-R1-592A	1				
R1-711		WTHSTP,FRONT HEADER			
NA01-R1-711B	1				

AUNA04

CAT. AUNA04-03

1995-04

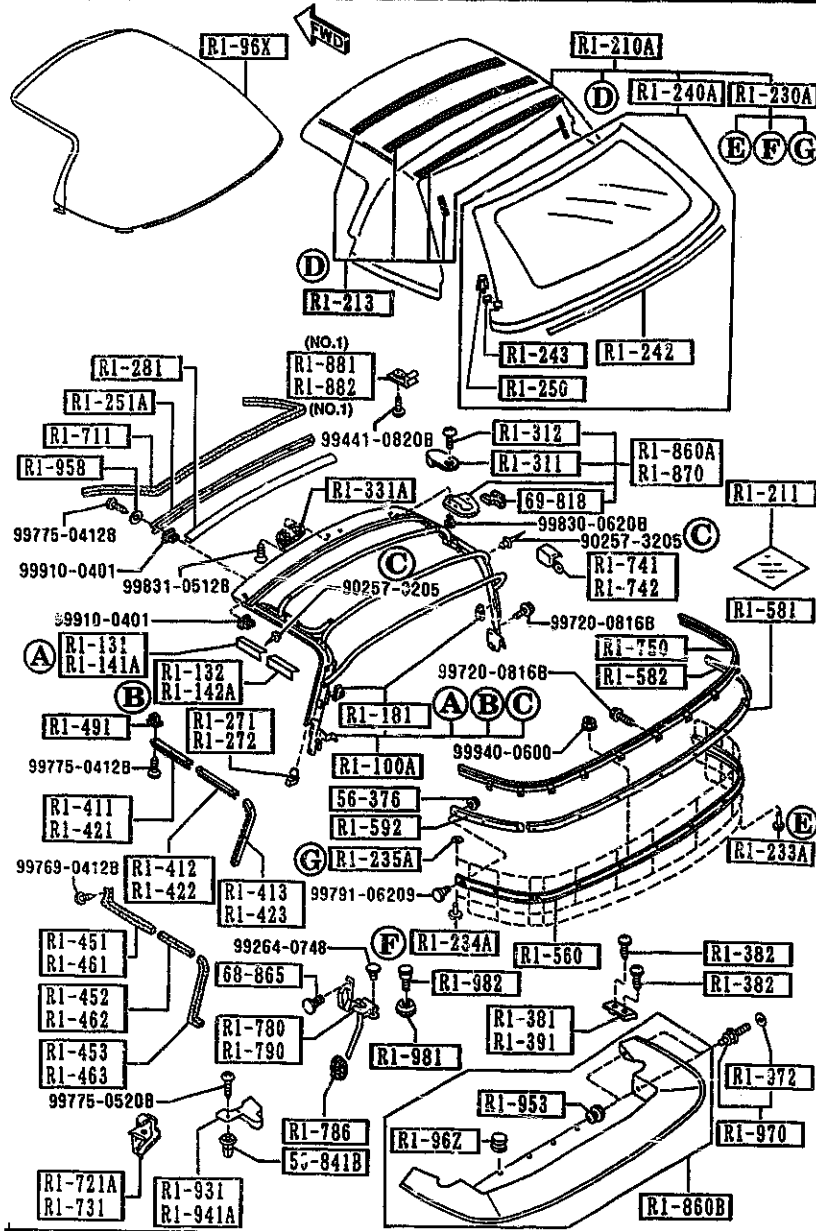

PART NO.	QTY	MODEL/RESTRICTION	MODEL/RESTRICTION	MODEL/RESTRICTION	FROM-TO
RI-721A		WTHSTP(R),CAB SIDE			
NA01-RI-721B	1				
RI-751		WTHSTP(L),CAB SIDE			
NA01-RI-751B	1				
RI-741		PROTR(R),MOULD-BELT LINE			
NA01-RI-741B	1				
RI-742		PROTR(L),MOULD-BELT LINE			
NA01-RI-742B	1				
RI-750		MOULD,BELTLINE-REAR			
NA01-RI-750D	1				
AN(NA01-RI-750E)					
*NA01-RI-750E	1				
RI-780		COVER(R),DRAIN-SOFT TOP			
NA01-RI-780C	1				
RI-786		GROMMET,DRAIN HOSE-TOP			
NA01-RI-786A	2				
RI-790		COVER(L),DRAIN-SOFT TOP			
NA01-RI-790C	1				
RI-810A		PANEL,ROOF			
NA06-RI-82X	1	(W/DETACHABLE HARD TOP)			
MB	EXT	MB MONTEGO BLUE M			
PT	EXT	PT CHAST WHITE			
PZ	EXT	PZ BRILLIANT BLACK			
SU	EXT	SU CLASSIC RED			
6W	EXT	6W LAGUNA BLUE M.			
RI-810C		ROOF,DETACHABLE TOP			
NA07-RI-810A	1	(W/DETACHABLE HARD TOP)			
MB	EXT	MB MONTEGO BLUE M			
PT	EXT	PT CHAST WHITE			
4703 NA3***-521342					

-4703
4703-

AUNA04

CAT. AUNA04-03

1995-04

2-H12

6330 SUNROOF
(W/DETACHABLE HARDTOP)

(2/2)

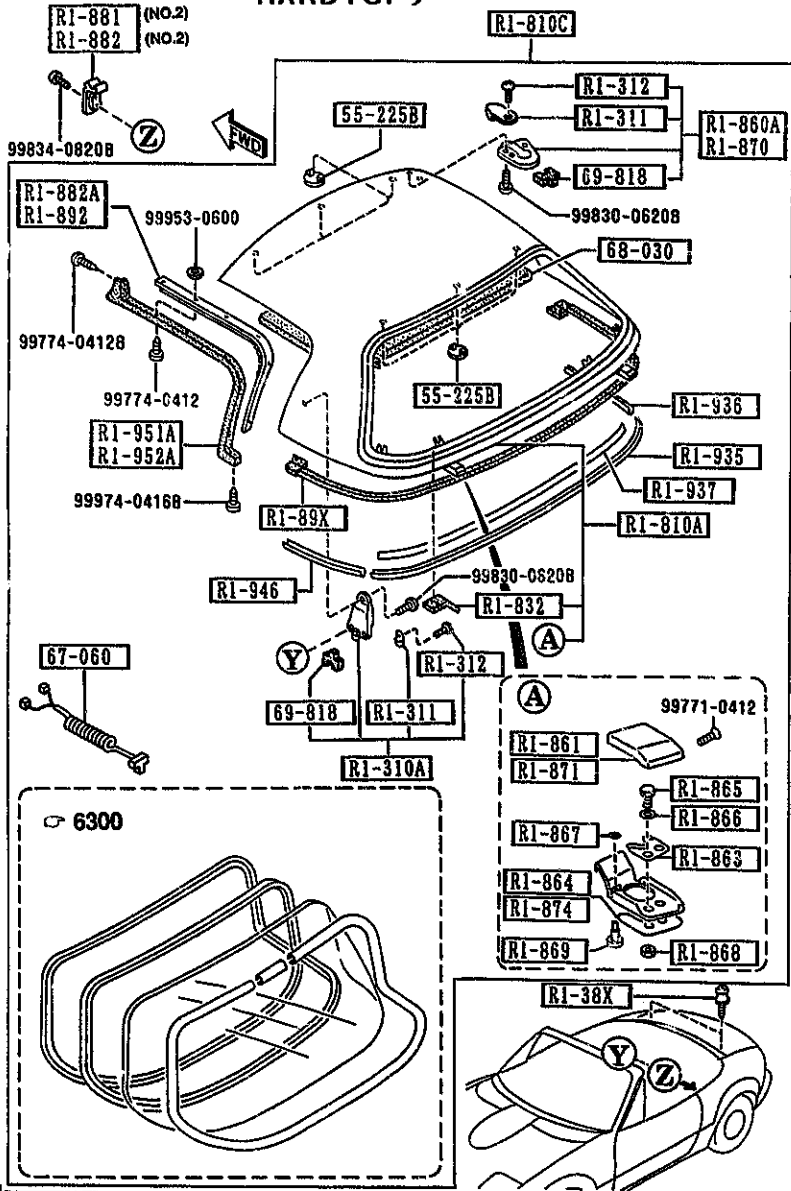

PART NO.	QTY	MODEL/RESTRICTION	MODEL/RESTRICTION	MODEL/RESTRICTION	FROM-TO
CONT'D					
PZ	EXT-	PZ BRILLIANT BLACK			
SU	EXT-	SU CLASSIC RED			
6W	EXT-	6W LAGUNA BLUE M.			
RI-832		PLATE,CUSHION-D. TOP			
NA01-RI-832A	2	(W/DETACHABLE HARD TOP)			
RI-860A		LOCK(R),TOP			
NA01-RI-310B AN(NA01-RI-310C)	1				-4201
NA01-RI-310B AN(NA01-RI-310C)	2				-4201
NA01-RI-310C	1	(W/O DETACHABLE HARD TOP)			4201-
NA01-RI-310C	2	(W/DETACHABLE HARD TOP)			4201-
RI-860B		BOOT, TOP			
NA01-RI-960E	1				
66	INT-	NA3 BLACK			
88	INT-	NA4 NA5 TAN			
RI-861		COVER(R),DECK LOCK			
NA01-RI-861	1	(W/DETACHABLE HARD TOP)			
RI-863		PLATE,DECK LOCK			
NA01-RI-863	2	(W/DETACHABLE HARD TOP)			
RI-864		SHEET(R),DECK LOCK			
NA01-RI-864	1	(W/DETACHABLE HARD TOP)			
RI-865		BOLT,DECK LOCK			
NA01-RI-865	4	(W/DETACHABLE HARD TOP)			
RI-866		WASHER'A',DECK LOCK			
NA01-RI-866	4	(W/DETACHABLE HARD TOP)			
4201 NA3***-511601					

AUNA04

CAT. AUNA04-03

1995-04

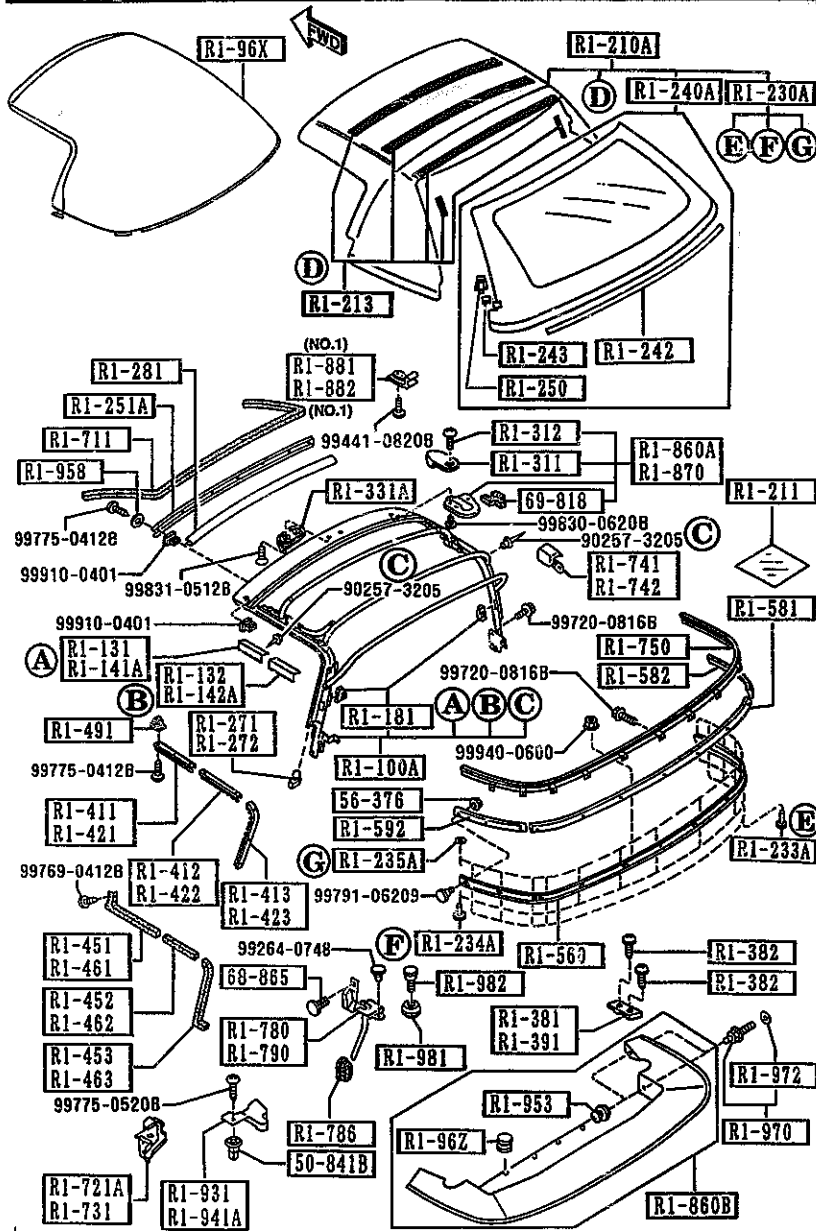

PART NO.	QTY	MODEL/RESTRICTION	MODEL/RESTRICTION	MODEL/RESTRICTION	FROM-TO
RI-867	2	WASHER*B',DECK LOCK			
NA01-RI-867	2	(W/DETACHABLE HARD TOP)			
RI-868	4	NUT,DECK LOCK			
NA01-RI-868	4	(W/DETACHABLE HARD TOP)			
RI-869	2	PIN,DECK LOCK			
NA01-RI-869	2	(W/DETACHABLE HARD TOP)			
RI-870	1	LOCK(L),TOP			
NA01-RI-320B	1				-6201
AN(NA01-RI-320C)	1				
NA01-RI-320B	2				-4201
AN(NA01-RI-320C)	2				
NA01-RI-320C	1	(W/O DETACHABLE HARD TOP)			4201-
NA01-RI-320C	2	(W/DETACHABLE HARD TOP)			4201-
RI-871	1	COVER(L),DECK LOCK			
NA01-RI-871	1	(W/DETACHABLE HARD TOP)			
RI-874	1	SHEET(L),DECK LOCK			
NA01-RI-874	1	(W/DETACHABLE HARD TOP)			
RI-881	1	STRIKER(R),LOCK-TOP			
NA01-RI-361B	1	(ILLUST. NO.1)			
NA02-RI-361B	1	(ILLUST. NO.2) (W/DETACHABLE HARD TOP)			
RI-882	1	STRIKER(L),LOCK-TOP			
NA01-RI-371B	1	(ILLUST. NO.1)			
NA02-RI-371B	1	(ILLUST. NO.2) (W/DETACHABLE HARD TOP)			
RI-882A	1	RETAINER(R),WTHSTP-D TOP			
NA01-RI-882	1	(W/DETACHABLE HARD TOP)			
4201 NA3***-511601					

6330 SUNROOF
(W/DETACHABLE HARDTOP)

(2/2)

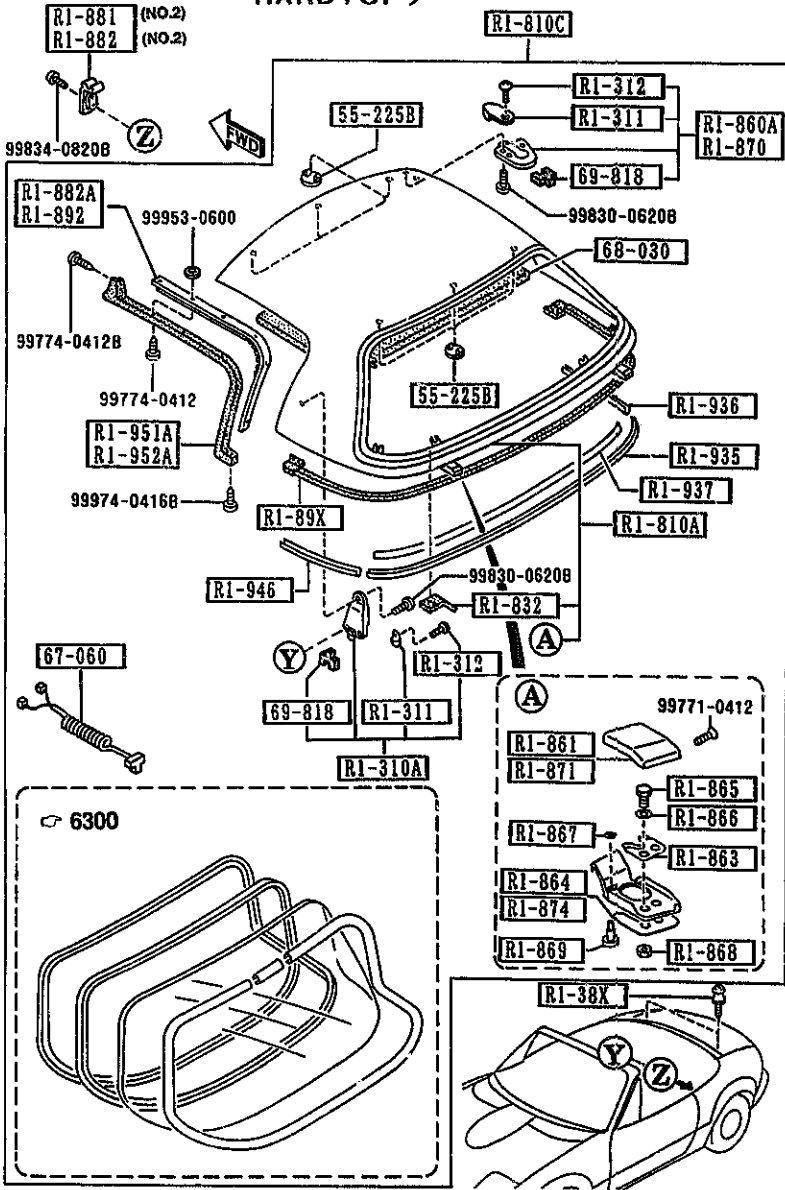

PART NO.	QTY	MODEL/RESTRICTION	MODEL/RESTRICTION	MODEL/RESTRICTION	FROM-TO
RI-89X NA01-R1-89XA	1	WEATHERSTRIP,D.TOP-R EAR (W/DETACHABLE HARD T OP)			
RI-892 NA01-R1-892	1	RETAINER(L),WTHSTP-D TOP (W/DETACHABLE HARD T OP)			
RI-931 NA01-R1-931A	1	COVER(R),BELT LINE			
RI-935 NA01-R1-935B	1	PROTECTOR(C),EDGE-D. TOP (W/DETACHABLE HARD T OP)			
RI-936 NA01-R1-936A	1	PROTECTOR(R),EDGE-D. TOP (W/DETACHABLE HARD T OP)			
RI-937 NAV1-R1-937	1	TAPE,EDGE PROTECTOR- CTR			
RI-941A NA01-R1-941A	1	COVER(L),BELT LINE			
RI-946 NA01-R1-946A	1	PROTECTOR(L),EDGE-D. TOP (W/DETACHABLE HARD T OP)			
RI-951A NA01-R1-881B	1	WTHSTP(R),ROOF PANEL (W/DETACHABLE HARD T OP)			
RI-952A NA01-R1-891B	1	WTHSTP(L),ROOF PANEL (W/DETACHABLE HARD T OP)			
RI-953 B235-R1-953	6	HOOK,HOOD-REAR CORNE R			
RI-958 B235-R1-958A	7	WASHER,HOOK'A'&'B'			

AUNA04

CAT. AUNA04-03

1995-04

6330 SUNROOF
(W/DETACHABLE HARDTOP)

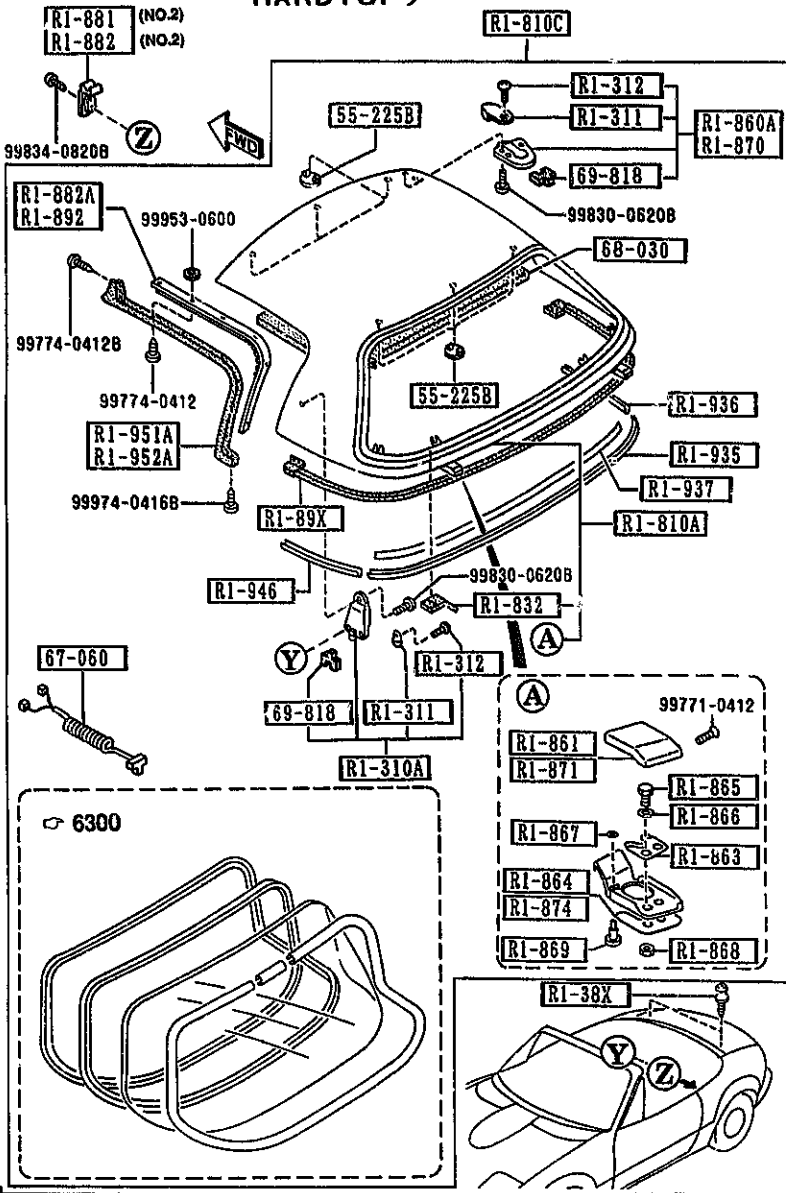

PART NO.	QTY	MODEL/RESTRICTION	MODEL/RESTRICTION	MODEL/RESTRICTION	FROM-TO
68-865		FASTENER			
0032-68-865A	2				
00	INT-	NA3 NA5 NA4 NA6 BLACK			
69-818		PAD			
NA01-RI-313	2	(W/D DETACHABLE HARD TOP)			
NA01-RI-313	6	(W/DETACHABLE HARD T OP)			

AUNA04

CAT. AUNA04-03

1995-04

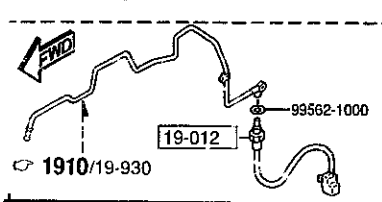
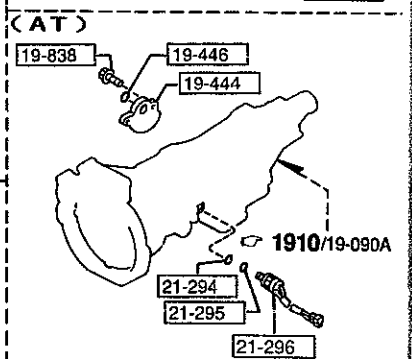
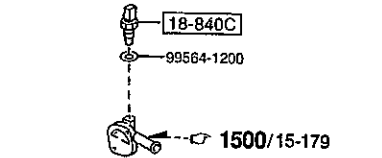
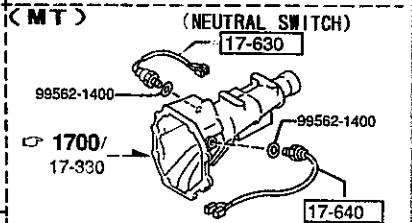
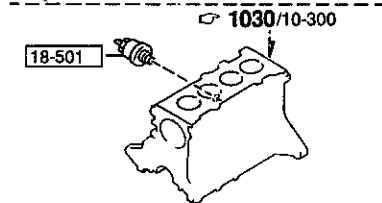
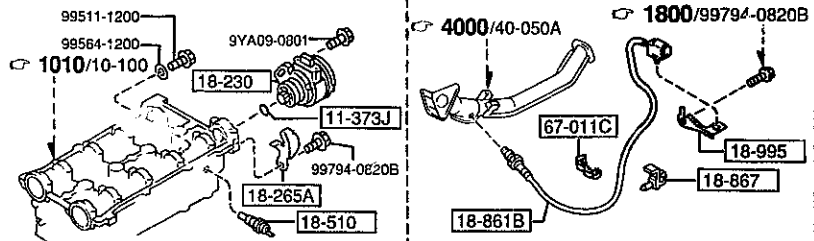
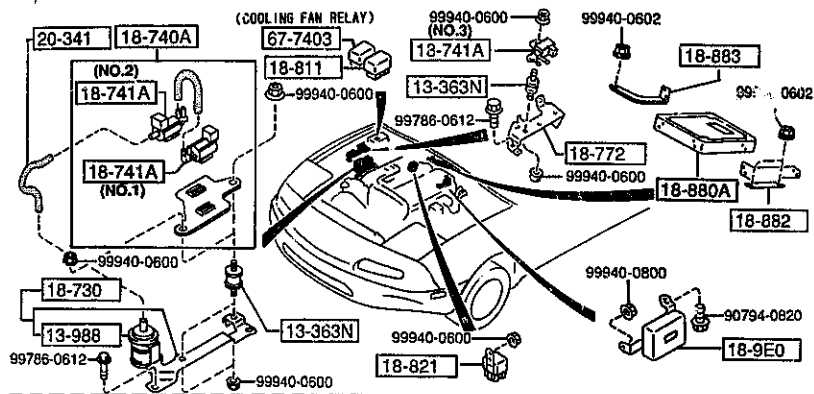

AUNA04

PART NO.	QTY	MODEL/RESTRICTION	MODEL/RESTRICTION	MODEL/RESTRICTION	FROM-TO
11-373J		RING, 'O'			
99541-03801	1				
13-363N		RUBBER, MOUNTING			
0222-13-363	3				
13-988		FILTER, AIR			
RFG1-13-988A	1				
17-630		SWITCH			
8118-17-640B	1				
17-640		SWITCH, BACK UP LAMP			
M506-17-640A	1				
18-230		SENSOR, CRANKSHAFT POSI.			
BPEB-18-230	1				
18-265A		BRACKET, COUPLER-KNOCK SENSOR			
BPEB-18-281A	1				
18-501		SWITCH, OIL PRESSURE			
B61P-18-501	1				
18-510		UNIT, HEAT GAUGE			
B541-18-51X	1	PANASONIC			
KL01-18-51X	1	NIHON THERMOSTAT			
18-730		FILTER, AIR			
BPEB-18-730	1				
18-740A		VALVE, SOLENOID			
BPEB-18-74X	1				
18-741A		VALVE, THREE WAY			
F2L3-18-741	1	(ILLUST. NO. 1)			
F2L4-18-741	1	(ILLUST. NO. 2)			
JE16-18-741	1	NIHON OIL SEAL (ILLUST. NO. 3)			

CAT. AUNA04-03

1985-04

6600 SWITCHES & RELAYS (ENGINE)

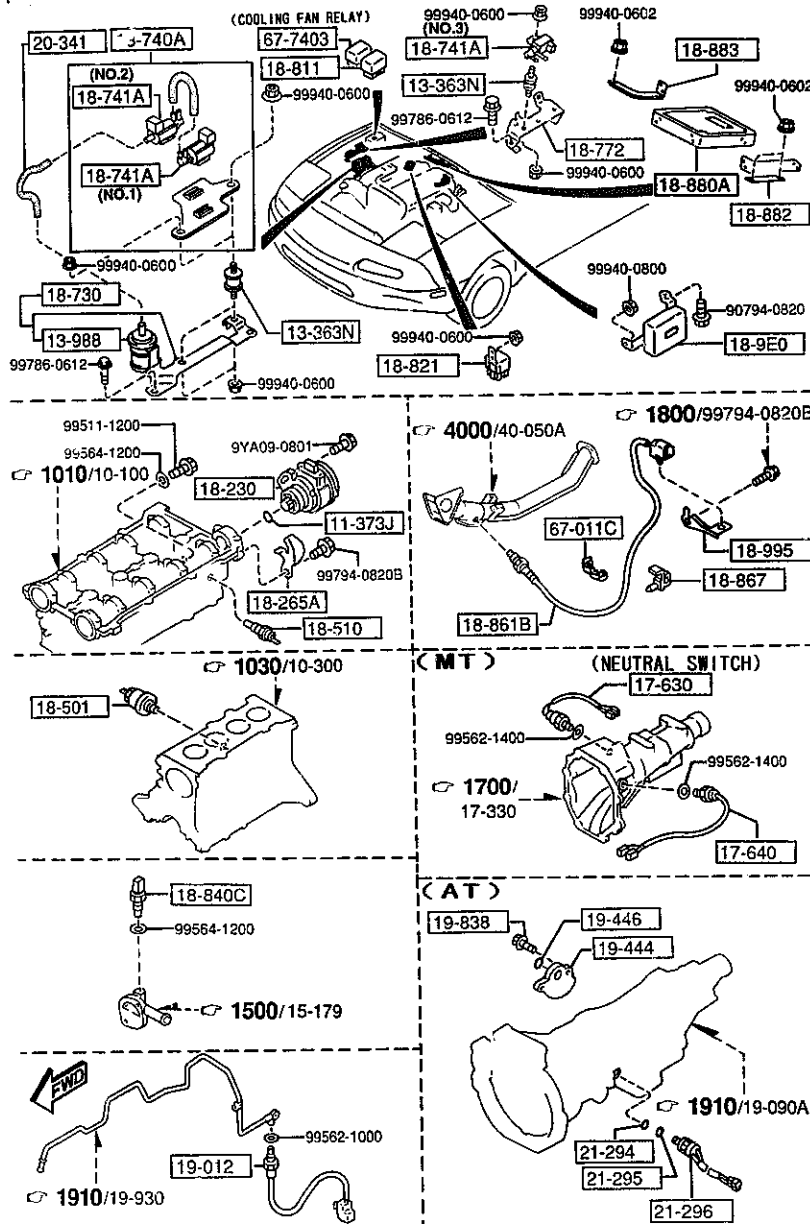

PART NO.	QTY	MODEL/RESTRICTION	MODEL/RESTRICTION	MODEL/RESTRICTION	FROM-TO
18-772		BRACKET,IGNITER			
BPE8-18-2F0	1				
18-811		RELAY,MAIN			
B6S8-18-811	1				
18-821		RELAY,FUEL PUMP			
B577-18-821A	1				
18-840C		SENSOR,TEMP.-ENG.COOLANT			
B593-18-840A	1				
18-861B		SENSOR,OXYGEN			
BPE8-18-861A	1				
18-867		CLIP			
BPE8-18-867A	1				
18-880A		MODULE,POW'RTRAIN CONTROL			
BPE8-18-881	1				
18-882		BRACKET,CONTROL UNIT			
BPE8-18-882	1				
18-883		BRACKET,CONTROL UNIT			
BPE8-18-883A	1				
18-9E0		MODULE,PWT.CONTROL			
BPE9-18-9E1A	1 (AT)				
18-995		CLIP			
BPE8-18-998B	1				
19-012		SENSOR,OIL TEMP			
N451-19-012A	1 (AT)				
19-444		SWITCH,INHIBITOR			
N451-19-444	1 (AT)				
19-446		RING,'O'			
0338-19-446	1 (AT)				

AUNA04

CAT. AUNA04-03

1995-04

6600 SWITCHES & RELAYS (ENGINE)

6600 -3 * SWITCHES & RELAYS (ENGINE)

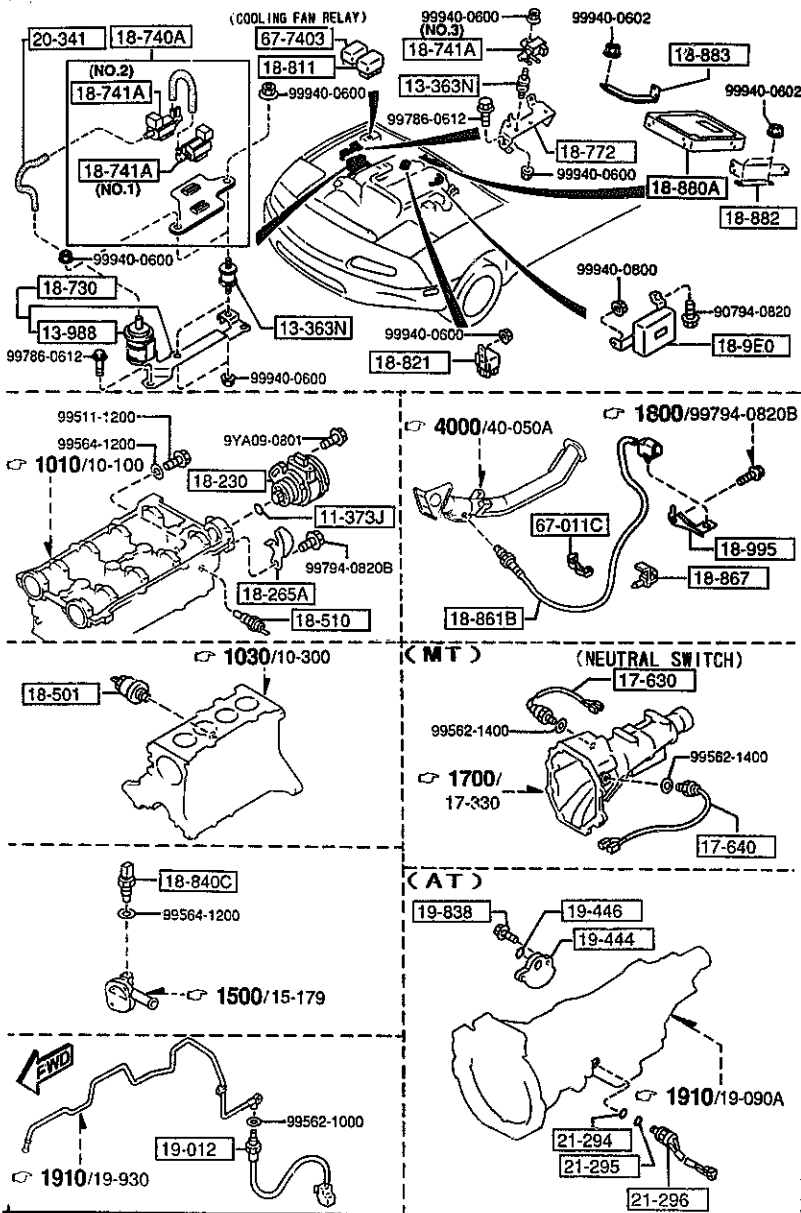

AUNA04

PART NO.	QTY	MODEL/RESTRICTION	MODEL/RESTRICTION	MODEL/RESTRICTION	FROM-TO
19-838		BOLT-HEX,HD WASHER			
1758-19-838A	2	(AT)			
20-341		HOSE,VACUUM			
BPE8-20-341	1				
21-294		RING,'O'			
BU01-21-294	1	(AT)			
21-295		RING,'O'			
BU01-21-295	1	(AT)			
21-296		SOLENOID,LOCK UP CON			
N451-21-3A5	1	TROL (AT)			
67-011C		CLIP			
E356-18-141	1				
67-7403		RELAY,H.O.			
LA18-67-740	1	10A (COOLING FAN RELAY)			

CAT. AUNA04-03

1995-04

6610 DASHBOARD SWITCHES

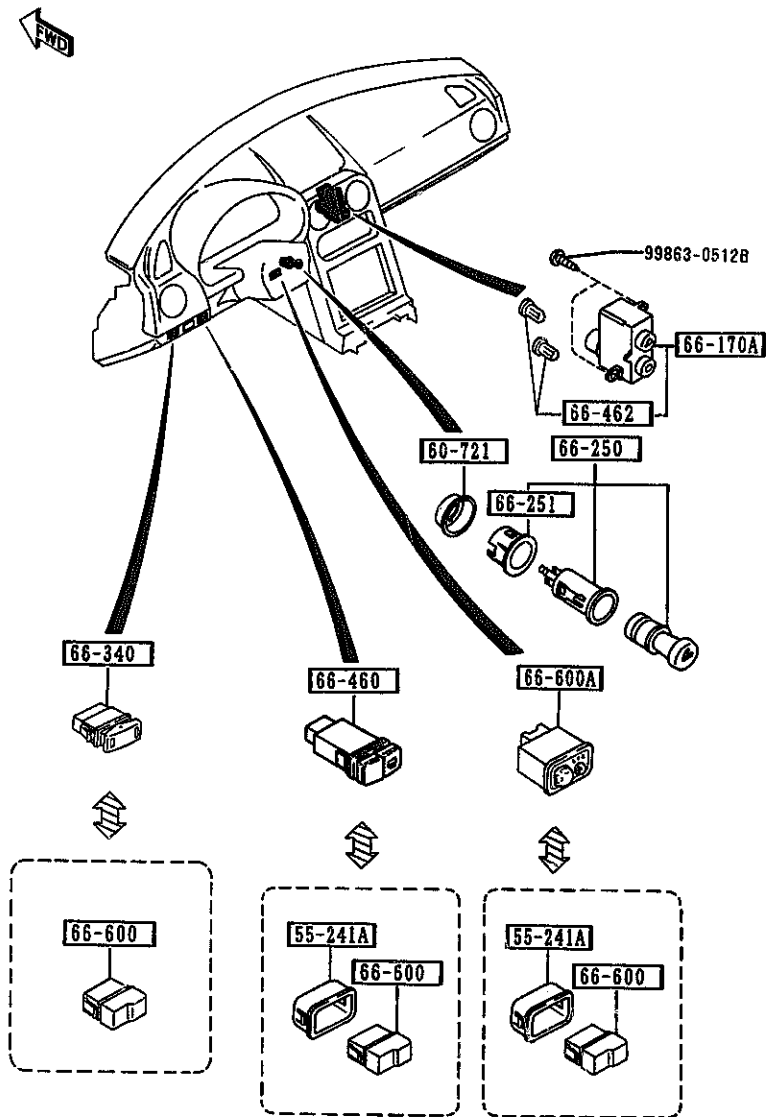

6610 -1 * DASHBOARD SWITCHES

PART NO.	QTY	MODEL/RESTRICTION	MODEL/RESTRICTION	MODEL/RESTRICTION	FROM-TO
55-241A		BOX, INSTRUMENT PANEL			
NA01-55-241A	2				
00	INT-	NA3 NA5 BLACK			
60-721		PROTECTOR			
B092-66-241A	1				
66-170A		SWITCH(R), CLUSTER			
NA01-66-170	1	(PLS CHECK LOCATION W/ILLUST.)			
66-250		LIGHTER, CIGAR			
B150-66-250	1				
66-251		RING, ILLUMINATION			
B001-66-251	1				
66-340		SWITCH, MAIN			
NA01-66-340A	1	PKG-B, PKG-C, (W/AUTO CRUISE. CONT.)			
66-460		SWITCH, RR. DEF.			
NA75-66-460	1	(W/DETACHABLE HARD TOP)			
66-462		BULB*B, SWITCH-RR DEF			
NA01-66-462	2				
66-600		COVER, HOLE			
B481-55-225	3				
66-600A		SWITCH, RMT. MIRROR			
NA52-66-600A	1	PKG-A, PKG-B, PKG-C, (DR MIRROR ELECT.)			

AUNA04

CAT. AUNA04-03

1995-04

6611 -1 * COMBINATION SWITCH

6611 COMBINATION SWITCH

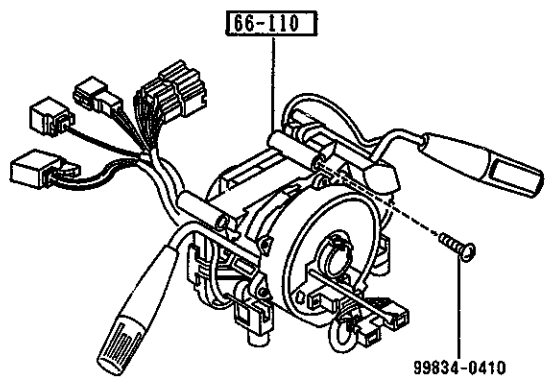

The inner parts of the combination switch with air bag are not serviced separately.

PART NO.	QTY	MODEL/RESTRICTION	MODEL/RESTRICTION	MODEL/RESTRICTION	FROM-TO
+-----+ 66-110 +-----+		SWITCH, COMBINATION			
NA01-66-120B	1	BASE, PKG-A, PKG-R, (W/O AUTO CRUISE.CON T.)			
NA02-66-120B	1	PKG-B, PKG-C, (W/AUTO CRUISE.CON T.)			

6630 RELAYS & UNIT (BODY)

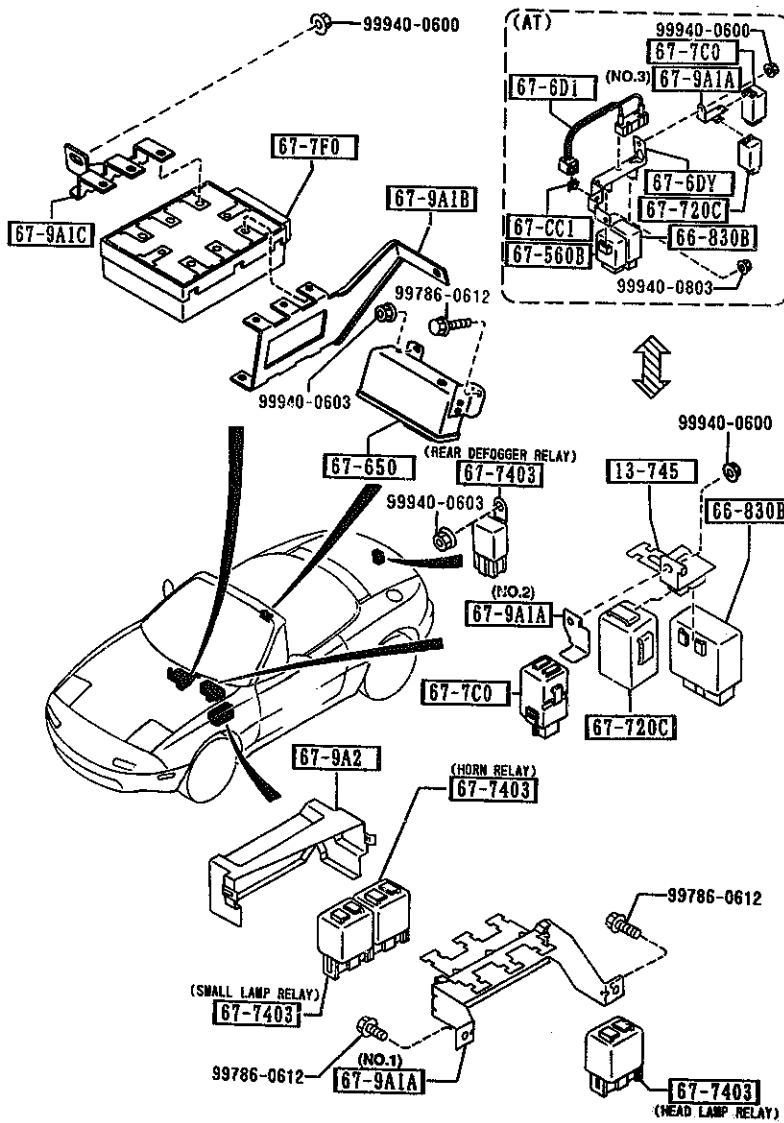

AUNA04

6630 -1 RELAYS & UNIT (BODY)

PART NO.	QTY	MODEL/RESTRICTION	MODEL/RESTRICTION	MODEL/RESTRICTION	FROM-TO
13-745		BRACKET,RELAY			
NA02-67-9A1	1				
66-830B		UNIT,FLASHER			
HE01-66-830	1				
67-CC1		CLIP,HARNES			
LA01-67-C11	1 (AT)				
67-560B		UNIT,CENTRAL PROCESSING			
NA56-67-560	1 (AT)				
67-6DY		BRACKET,RELAY-INTERLOCK			
NA56-67-6DYA	1 (AT)				
67-6D1		RESISTOR,INTERLOCK			
M020-67-6D1	1 (AT)				
67-650		BOX,CONTROL-A.B.S.			
NA80-67-650	1 (A.LOCK BRAKE)				
67-7C0		RELAY,RETRACTOR-COWL PANEL			
B481-67-7C0B	1				
67-7F0		UNIT,DIAGNOSIS-AIR BAG			
GA2A-67-7F0A	1				
67-720C		TIMER & BUZZER			
NA02-67-720	1				
67-7403		RELAY,N.O.			
H300-67-740	1 30A (HEAD LAMP RELAY)				
LA10-67-740	2 10A (HORN RELAY) (SMALL LAMP RELAY)				
LA40-67-740	1 (REAR DEFOGGER RELAY) (W/DETACHABLE HARD TOP)				
67-9A1A		BRACKET,RELAY			
NA01-67-9A1	1 (ILLUST. NO.1)				

CAT. AUNA04-03

1995-04

6630 RELAYS & UNIT (BODY)

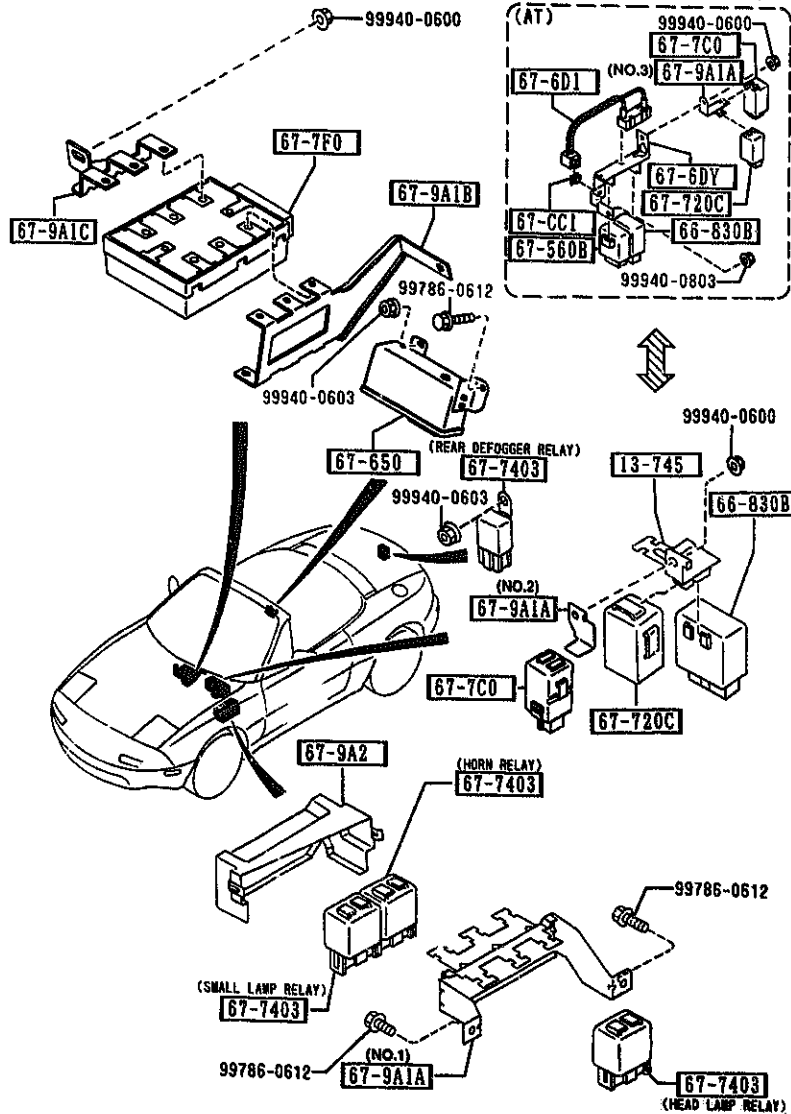

AUNA04

6630 -2 * RELAYS & UNIT (BODY)

PART NO.	QTY	MODEL/RESTRICTION	MODEL/RESTRICTION	MODEL/RESTRICTION	FROM-TO
CONT'D					
NA17-67-9A1	1	(ILLUST. NO.2) (MT)			
NA81-67-9A1	1	(ILLUST. NO.3) (AT)			
67-9A1B		BRKT,DIAGNOSIS UNIT			
NA06-67-9A1B	1				
67-9A1C		BRKT,DIAGNOSIS/POWER UNIT			
NA05-67-9A1B	1				
67-9A2		COVER,RELAY			
NA02-67-9A2	1				

CAT. AUNA04-03

1995-04

6635 DOOR SWITCH & HORNS

6635 -1 * DOOR SWITCH & HORNS

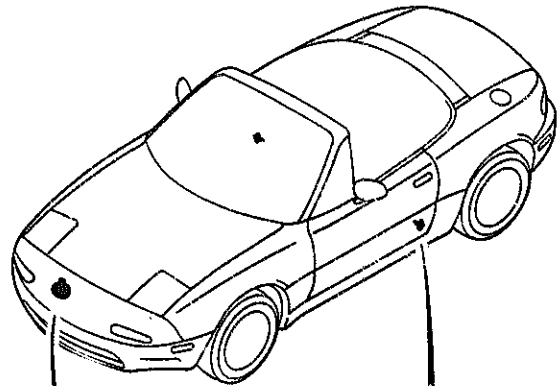

PART NO.	QTY	MODEL/RESTRICTION	MODEL/RESTRICTION	MODEL/RESTRICTION	FROM-TO
66-546 LA01-66-546	2	SCREW, DOOR SWITCH			
66-790 SA59-66-790	1	HORN, LOW TONE			
66-820 B455-66-540	2	SWITCH, DOOR			

AUNA04

CAT. AUNA04-03

1995-04

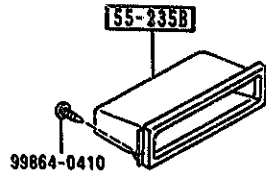
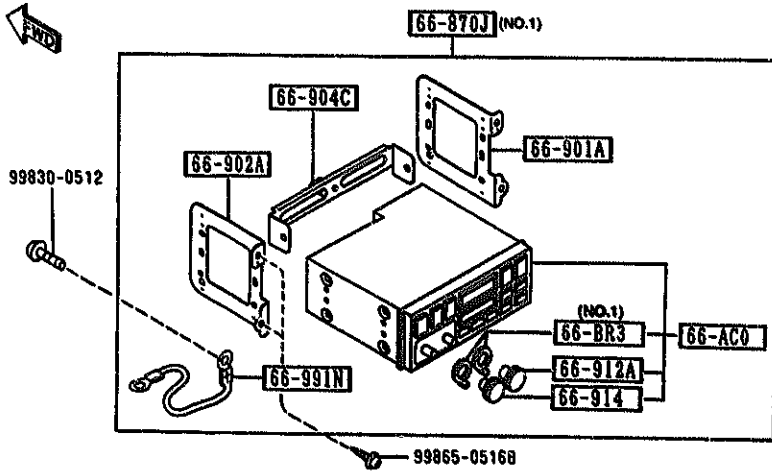

(W/C. D., W/O SENSORY SOUND)

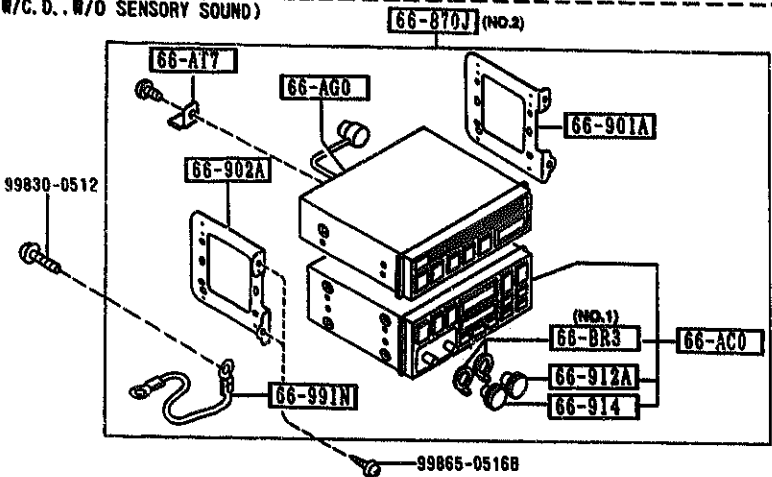

AUNA04

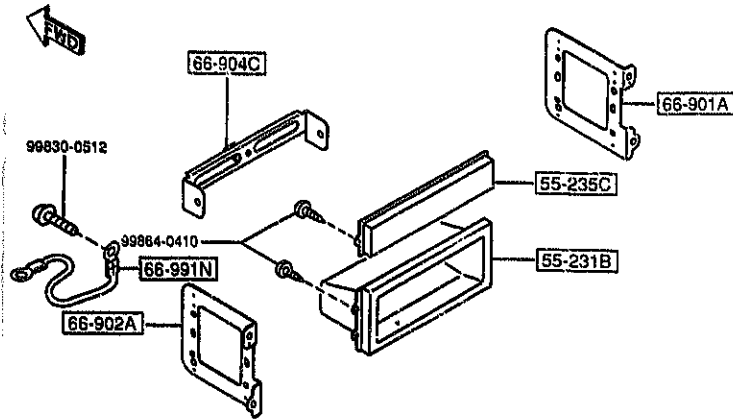

(W/C. D., W/SENSORY SOUND)

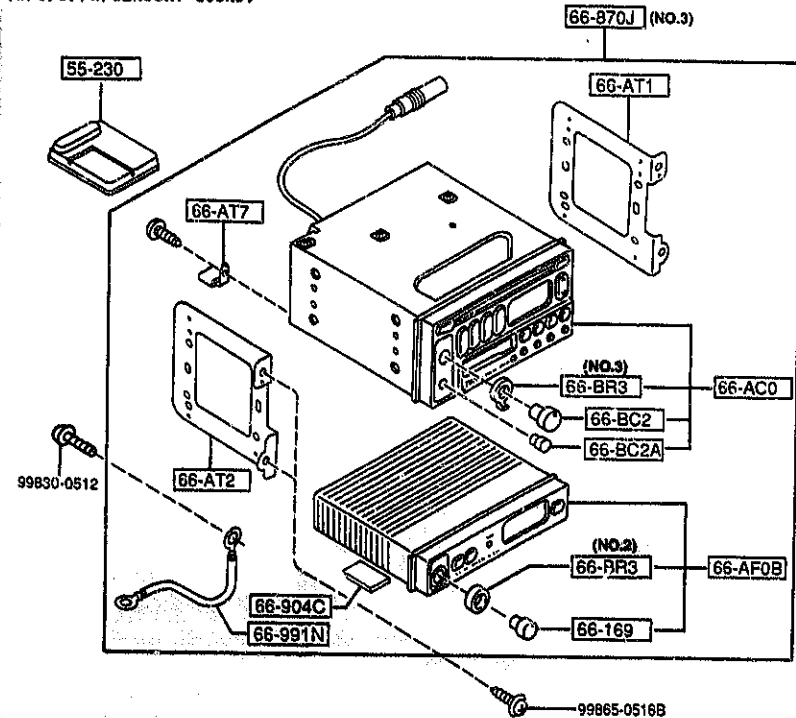

AUNA04

(NO.1)
66-870J

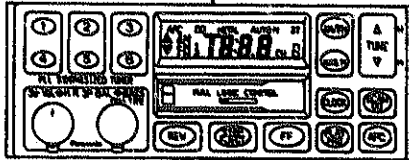

(NO.3)
66-870J

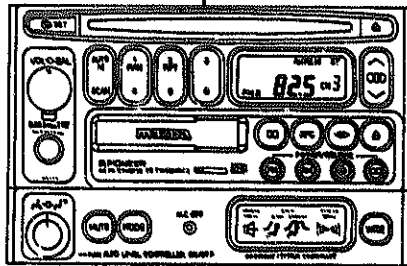

(NO.2)
66-870J

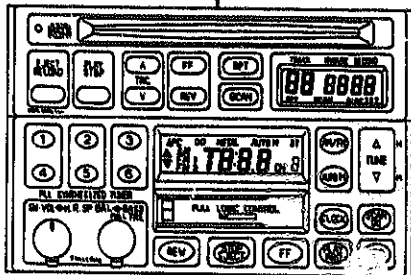

AUNA04

6680 AUDIO SYSTEMS (RADIO & TAPE DECK)

(1/3)

(W/O C. D., W/O SENSORY SOUND)

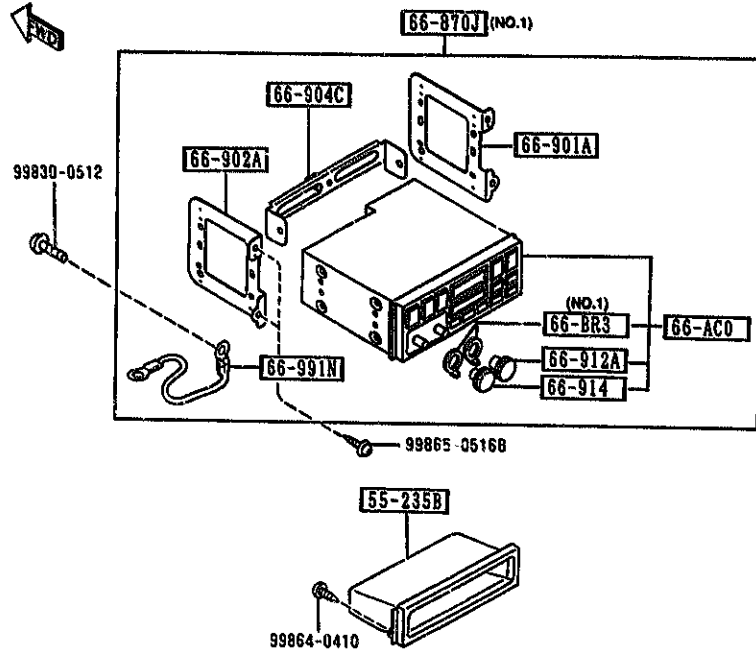

(W/C. D., W/O SENSORY SOUND)

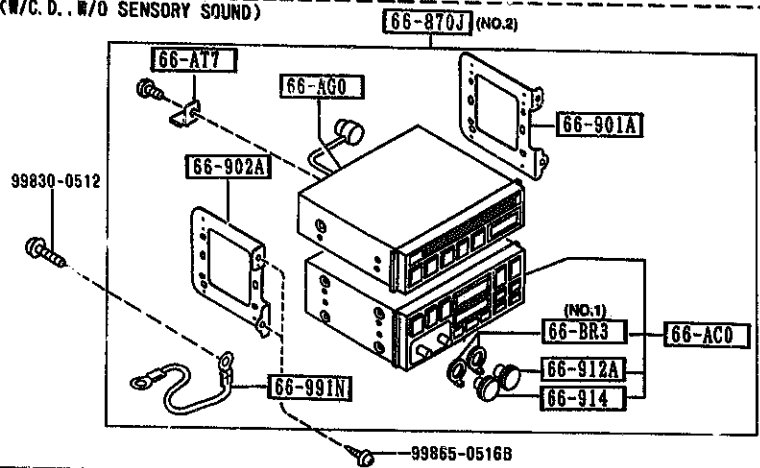

AUNAO4

6680 -1 AUDIO SYSTEMS (RADIO & TAPE DECK)

PART NO.	QTY	MODEL/RESTRICTION	MODEL/RESTRICTION	MODEL/RESTRICTION	FROM-TO
55-230		PANEL,AUDIO			
NA52-66-9H1	1	(W/SENSORY SOUND)			
55-231B		ORNAMENT,STEREO			
FC02-55-235A	1	(W/O AUDIO)			
55-235B		ORNAMENT,STEREO-UPPER			
LA03-55-235A	1	(AM/FM,W/O C.DISC)			
55-235C		ORNAMENT,STEREO-LOWER			
LA02-55-235	1	(W/O AUDIO)			
66-AC0		TUNER & DECK,COMB.			
NA01-66-AC0A	1	(W/O SENSORY SOUND)			
NA52-66-AC0A	1	(W/SENSORY SOUND)			-3901
NA52-66-AC0B	1	(W/SENSORY SOUND)			3901-
66-AF0B		SOUND CONTROLLER			
NA52-66-AF0	1	(W/SENSORY SOUND)			
NA52-66-AF0A	1	(W/SENSORY SOUND)			-3901
66-AG0		PLAYER,COMPACT DISC			
NA01-66-AG0	1	(W/C.D.,W/O SENSORY SOUND)			3901-
66-AT1		BRACKET(R),FRONT-AUDIO			
NO18-66-AS1	1	(W/SENSORY SOUND)			
66-AT2		BRACKET(L),FRONT-AUDIO			
NO18-66-AS2	1	(W/SENSORY SOUND)			
66-AT7		BRACKET(RR),AUDIO			
NO18-66-AS3	1	(W/C.D.,W/SENSORY SOUND)			
NO19-66-AT7	1	(W/C.D.,W/O SENSORY SOUND)			
66-BC2		KNOB,VOLUME-TUNER & DECK			
NO18-66-BC1	1	(W/SENSORY SOUND)			
66-BC2A		KNOB,BASS/TREBLE			

3901 NA3***-502360

CAT. AUNAO4-03

1995-04

(W/O AUDIO)

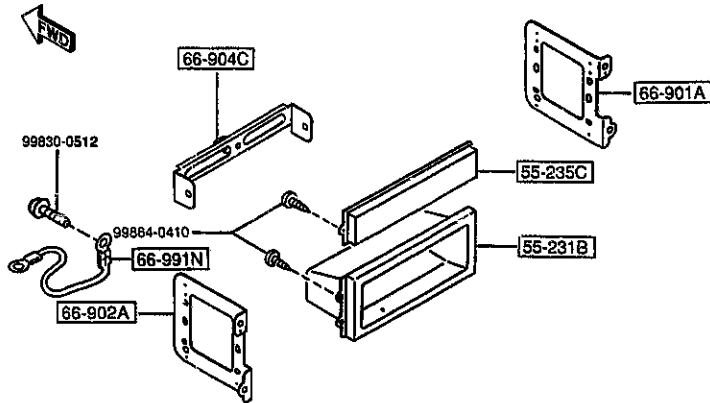

(W/C.D., W/SENSORY SOUND)

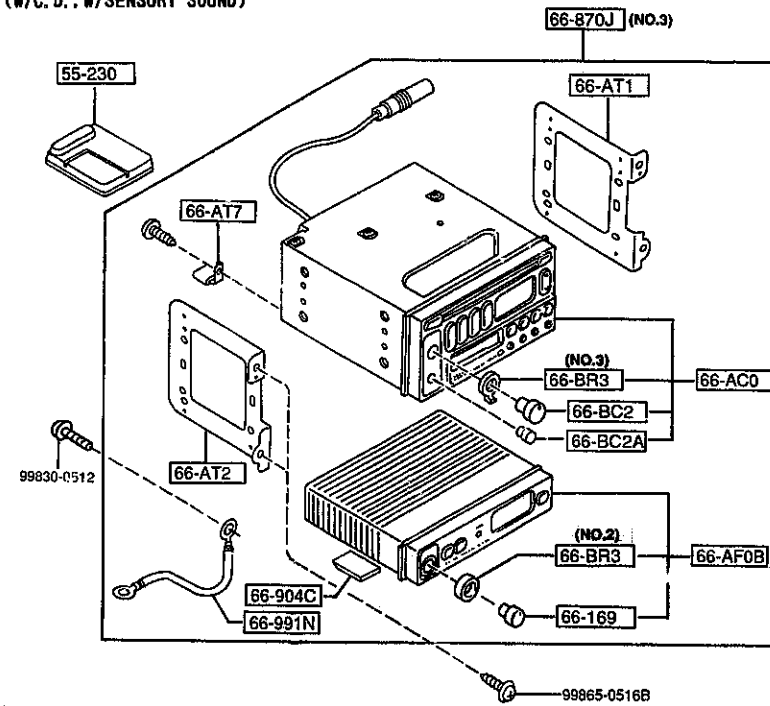

AUNAD4

PART NO.	QTY	MODEL/RESTRICTION	MODEL/RESTRICTION	MODEL/RESTRICTION	FROM-TO
CONT'D					
NA52-66-BC2	1	(W/SENSORY SOUND)			
66-BR3		KNOB, BALANCE-TUNER			
NA01-66-BR3	2	(ILLUST. NO. 1) (W/O SENSORY SOUND)			
NA52-66-BR3	1	(ILLUST. NO. 2) (W/SENSORY SOUND)			
NO18-66-BR3	1	(ILLUST. NO. 3) (W/SENSORY SOUND)			
66-169		KNOB			
NA52-66-BC3	1	(W/SENSORY SOUND)			
66-870J		AUDIO SET			
NA53-66-9C0	1	(ILLUST. NO. 1) (W/O C.D., W/O SENSORY SOUND)			
NA54-66-9W0	1	(ILLUST. NO. 2) (W/C.D., W/C SENSORY SOUND)			
NA52-66-9W0A AN(NA52-66-9W0B)	1				-3901
NA52-66-9W0B	1	(ILLUST. NO. 3) (W/O C.D., W/SENSORY SOUND)			3901-
66-901A		BRACKET(R), TUNER			
NA01-66-AT1	1	(W/O SENSORY SOUND)			
66-902A		BRACKET(L), TUNER			
NA01-66-AT2	1	(W/O SENSORY SOUND)			
66-904C		BRACKET, LOW			
NO19-66-AT6	1	(W/O C.D.)			
NO18-66-AS6	2	(W/C.D., W/SENSORY SOUND)			3C01-
66-912A		KNOB, TONE-TUNER			
NA01-66-BR2	1	(W/O SENSORY SOUND)			
66-914		KNOB, VOLUME-TUNER			
NA01-66-BR1	1	(W/O SENSORY SOUND)			
66-991N		CORD, EARTH			
3901 NA3***-502360					
3C01 NA3***-507607					

CAT. AUNAD4-03

1995-04

2-N13

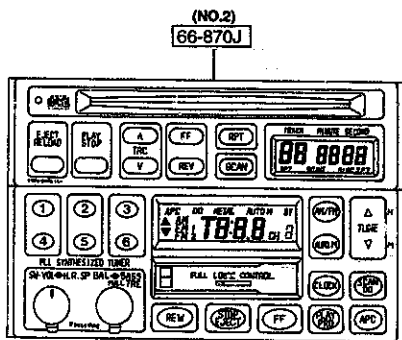
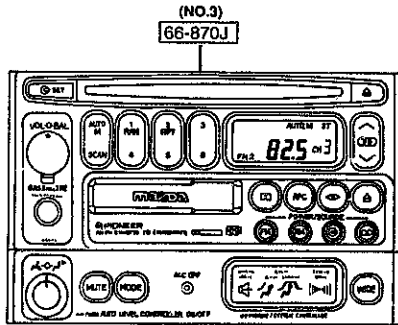
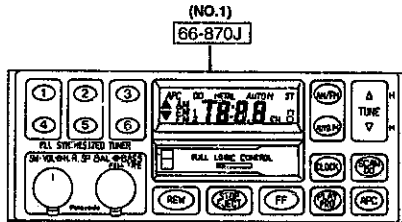

AUNA04

PART NO.	QTY	MODEL/RESTRICTION	MODEL/RESTRICTION	MODEL/RESTRICTION	FROM-TO
CONT'D					
NA01-66-997	1	(W/O SENSORY SOUND)			
NO18-66-997	1	(W/SENSORY SOUND)			

CAT. AUNA04-03

1995-04

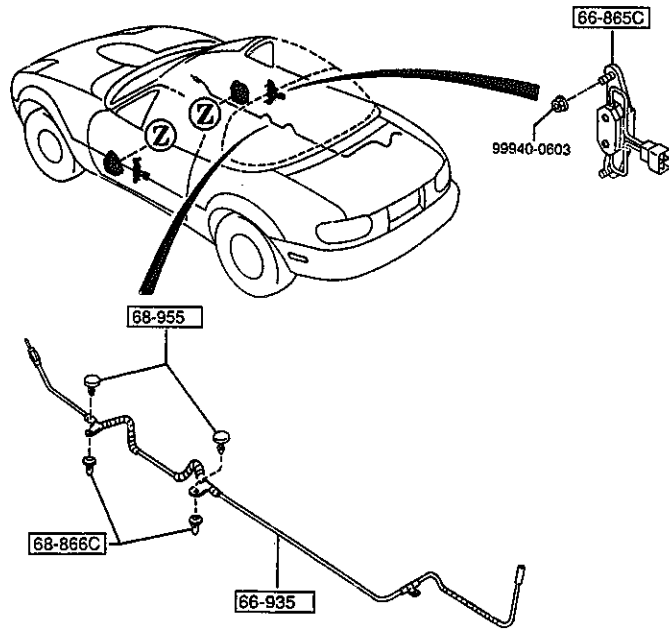
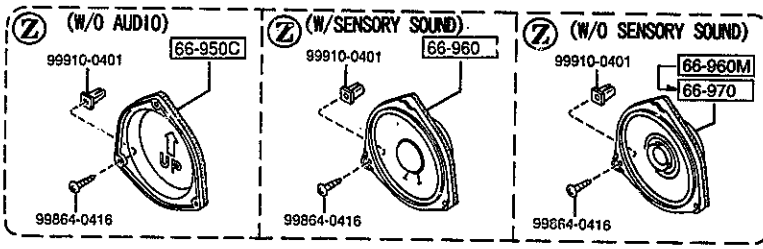

AUNA04

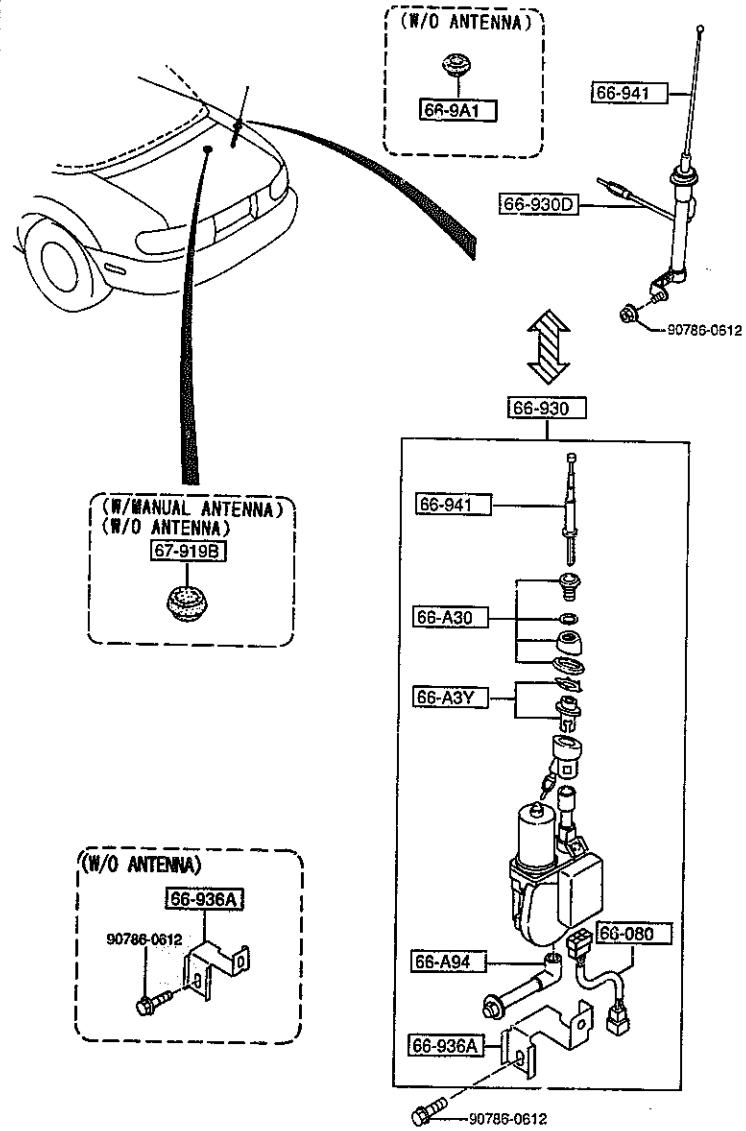

AUNA04

6682 AUDIO SYSTEMS (ANTENNA & SPEAKER)

(1/2)

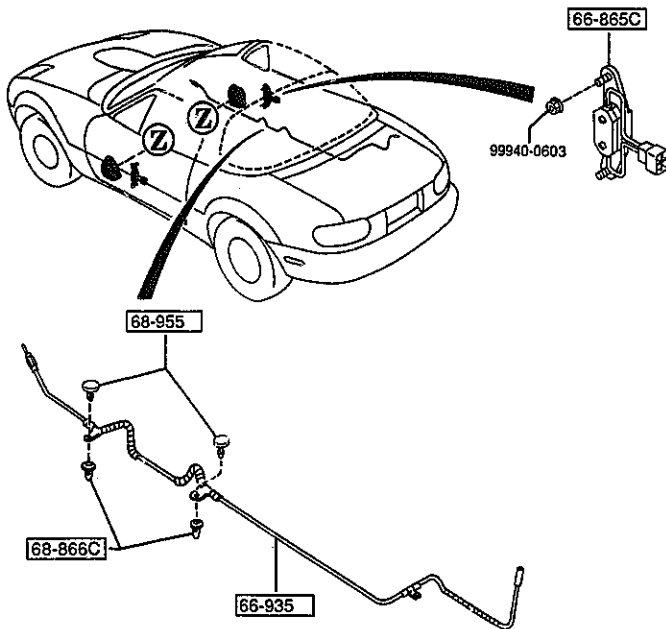
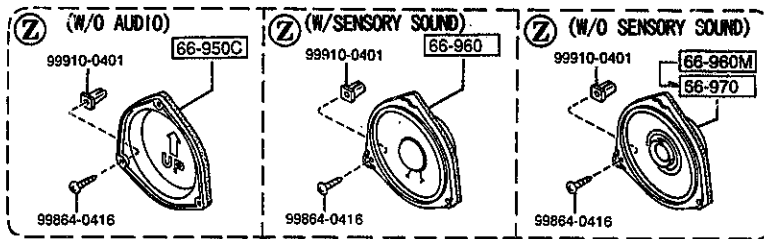

6682 -1 AUDIO SYSTEMS (ANTENNA & SPEAKER)

PART NO.	QTY	MODEL/RESTRICTION	MODEL/RESTRICTION	MODEL/RESTRICTION	FROM-TO
66-A3Y		PLATE, EARTH-MOTOR AN TENNA			
*N007-66-A3Z	1	PKG-B, PKG-C, (W/ELECT. ANTENNA)			4601-
66-A30		NUT, MOUNTING-ANTENNA			
*N007-66-A9Y	1	PKG-B, PKG-C, (W/ELECT. ANTENNA)			4601-
66-A94		PIPE, DRAIN-ANTENNA			
*N007-66-A90	1	PKG-B, PKG-C, (W/ELECT. ANTENNA)			4601-
66-080		CORD			
*N007-66-D10	1	PKG-B, PKG-C, (W/ELECT. ANTENNA)			4601-
66-865C		SUPPRESSOR, IG.			
N018-66-991A	2	(W/SENSORY SOUND)			
66-9A1		COVER, HOLE-ANTENNA			
F001-66-9A1A	1	(W/O ANTENNA)			
66-930		ANTENNA, RADIO			
N007-66-930A	1	PKG-B, PKG-C, (W/ELECT. ANTENNA)			
66-930D		BODY, LOW-RADIO ANTEN NA			
NA01-66-A3XA	1	BASE, PKG-A, PKG-R, (W/MANUAL ANTENNA)			
66-935		FEEDER-ANTENNA			
NA01-66-940C	1				
66-936A		BRKT, MOTOR-ANTENNA			
N007-66-A9X	1	PKG-B, PKG-C, (W/ELECT. ANTENNA) (W/O ANTENNA)			
66-941		POLE, ANTENNA			
N001-66-A30	1	BASE, PKG-A, PKG-R, (W/MANUAL ANTENNA)			
*N007-66-A3X	1	PKG-B, PKG-C, (W/ELECT. ANTENNA)			4601-
4601 NA3***-519089					

AUNA04

CAT. AUNA04-03

1995-04

2-E14

6682 AUDIO SYSTEMS (ANTENNA & SPEAKER)

(2/2)

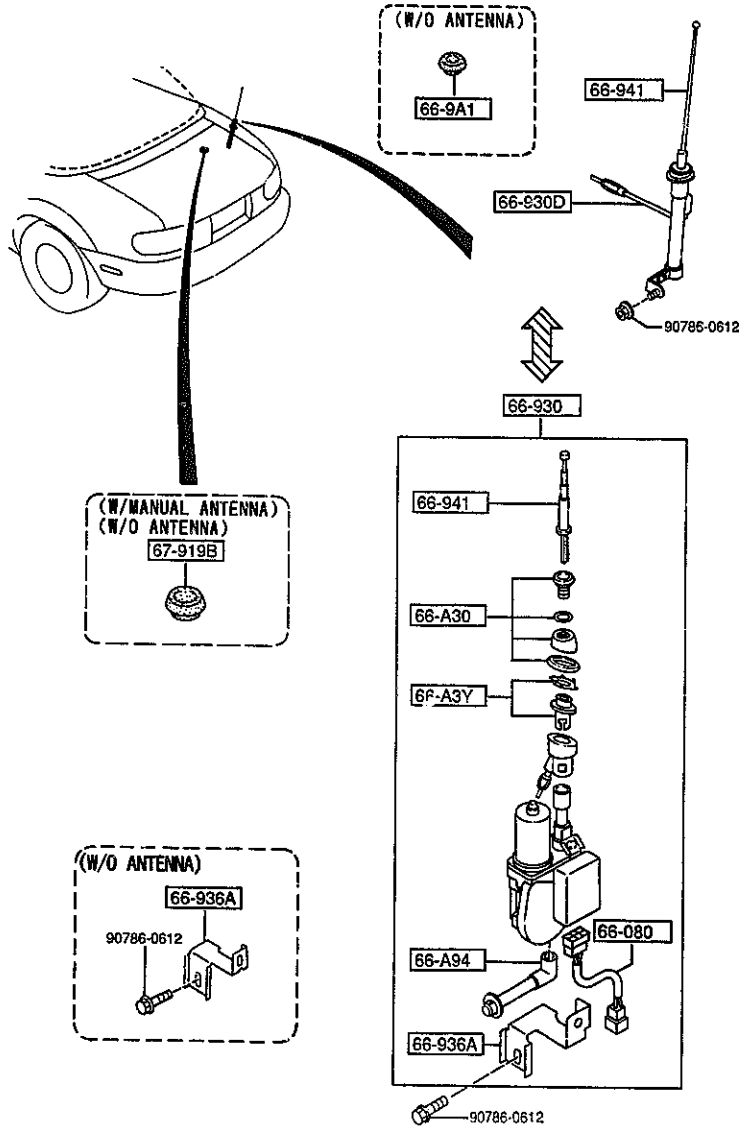

6682 -2 * AUDIO SYSTEMS (ANTENNA & SPEAKER)

PART NO.	QTY	MODEL/RESTRICTION	MODEL/RESTRICTION	MODEL/RESTRICTION	FROM-TO
66-950C		BRACKET, LOUD SPEAKER			
NA01-66-980A	2	(W/O AUDIO)			
66-960		SPEAKER, LOUD-FRONT			
ND18-66-960A	2	(W/SENSORY SOUND)			
66-960M		SPEAKER, LOUD-DOOR			
NA03-66-96X	2	(W/O SENSORY SOUND)			-3B16
66-970		SPEAKER, LOUD-REAR			
B01F-66-960	2	(W/O SENSORY SOUND)			3B16-
67-919B		GROMMET			
N007-67-G11	1	BASE, PKG-A, PKG-R, (W/MANUAL ANTENNA) (W/O ANTENNA)			
68-866C		FASTENER, SEAL			
B235-68-865A	2				
68-955		FASTENER, LIFT GATE T RIM			
GJ37-68-955	2				
00	INT-	NA3 NA5 NA4 NA6 BLACK			

3B16 NA3***-506855

AUNA04

CAT. AUNA04-03

1995-04

6700 WIRING HARNESSES(FRONT & REAR)

6700 -1 WIRING HARNESSES(FRONT & REAR)

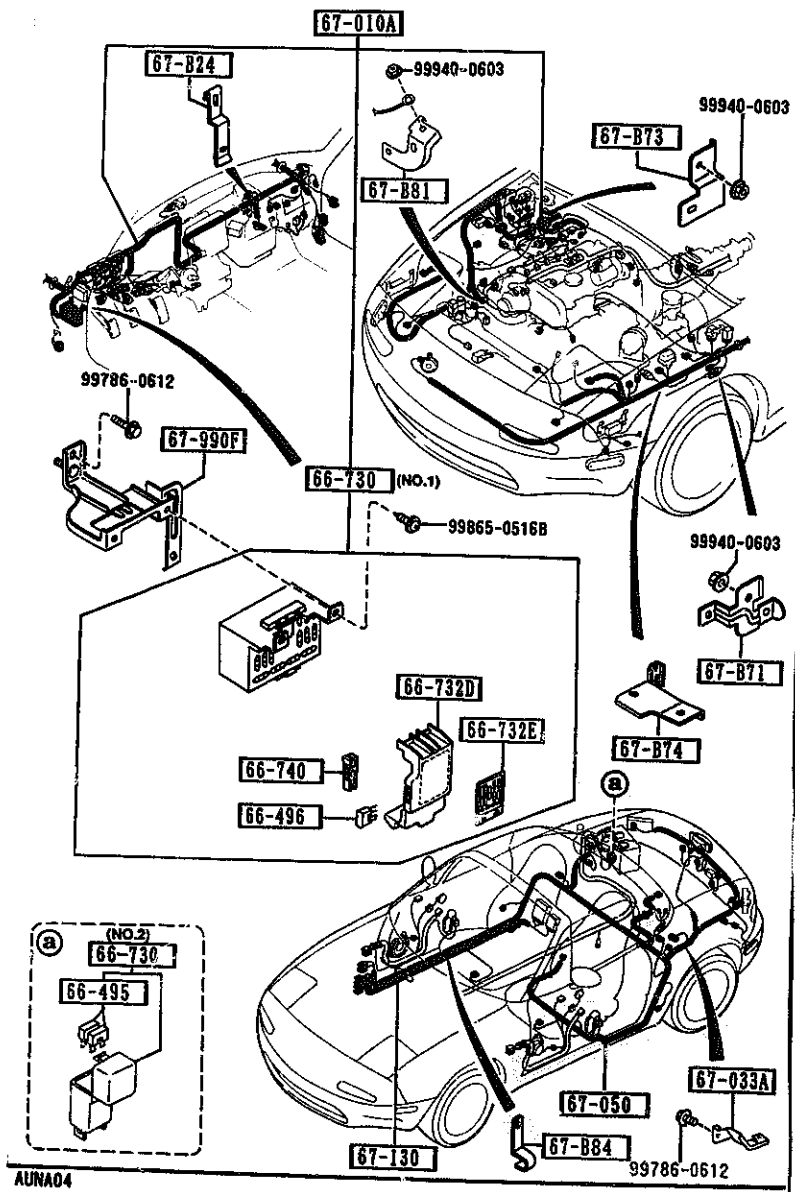

AUNA04

PART NO.	QTY	MODEL/RESTRICTION	MODEL/RESTRICTION	MODEL/RESTRICTION	FROM-TO
66-495		FUSE(10A)			
99705-1110	2				
66-496		FUSE(15A)			
99705-1115	1	(W/AIR BAG-DRIV.&PAS S.SIDE)			
66-730		BLOCK,FUSE			
NA75-66-730	1	(ILLUST. NO.1) (W/AIR BAG-DRIV.&PAS S.SIDE)			
N008-66-730	1	(ILLUST. NO.2)			
66-732D		COVER,FUSE BLOCK			
NA01-66-731A	1	FURUKAWA (W/AIR BAG-DRIV.&PAS S.SIDE)			
66-732E		LABEL,CAUTION-FUSE COVER			
NA75-66-732	1	(W/AIR BAG-DRIV.&PAS S.SIDE)			
66-740		HOLDER,FUSE			
H001-66-739	1	(W/AIR BAG-DRIV.&PAS S.SIDE)			
67-B24		BRACKET			
NA75-67-B11 AN(NA75-67-B11A)	1				-4401
NA75-67-B11A	1				4401-
67-B71		BRACKET,HARNESS			
NA05-67-BW1B	1				
67-B73		BRACKET,HARNESS			
NA05-67-BW2	1				
67-B74		BRACKET,HARNESS			
N018-67-BW0	1				
67-B81		BRACKET,HARNESS-ENGINE			
NA75-67-B81	1				
4401 NA3***-517818					

CAT. AUNA04-03

1995-04

6700 WIRING HARNESSSES(FRONT & REAR)

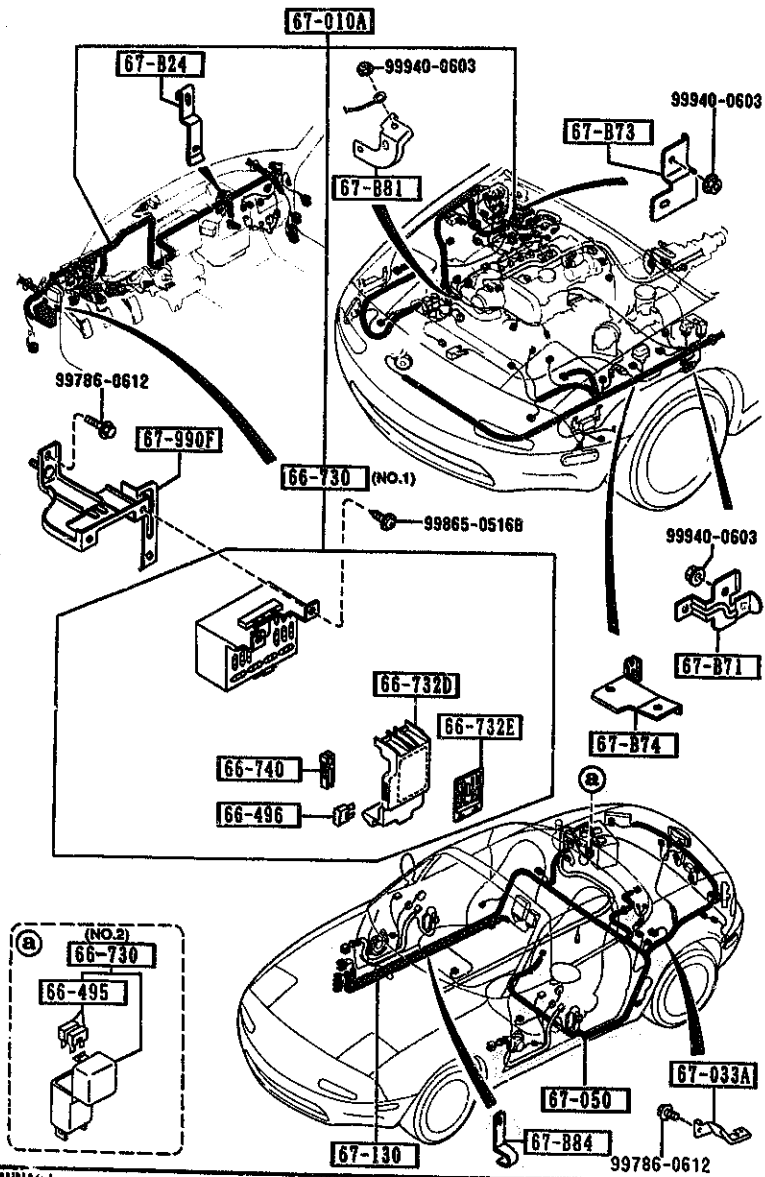

AUNA04

6700 -2 * WIRING HARNESSSES(FRONT & REAR)

PART NO.	QTY	MODEL/RESTRICTION	MODEL/RESTRICTION	MODEL/RESTRICTION	FROM-TO
67-B84		BRACKET			
NA75-67-B12	1				
67-010A		HARNESS,FRONT			
NA81-67-010D	1	(W/AIR BAG-DRIV.&PAS S.SIDE) (AT)>(W/O A.LOCK BR AKE)			
NA82-67-010D	1	(W/AIR BAG-DRIV.&PAS S.SIDE) (AT)>(A.LOCK BRAKE)			
NA75-67-010D A (NA75-67-010E)	1				-3C01
NA80-67-010D A (NA80-67-010E)	1				-3C01
NA75-67-010E	1	(W/AIR BAG-DRIV.&PAS S.SIDE) (MT)>(W/O A.LOCK BR AKE)			3C01-
NA80-67-010E	1	(W/AIR BAG-DRIV.&PAS S.SIDE) (MT)>(A.LOCK BRAKE)			3C01-
67-033A		BRACKET,WIRING			
NA07-67-B10A	1				
67-050		HARNESS,REAR			
NA75-67-050C	1	(W/O A.LOCK BRAKE)			
NA80-67-050C	1	(A.LOCK BRAKE)			
67-130		HARNESS'NO.2',FRONT			
NA80-67-110C A (NA80-67-110E)	1				-4106
NA82-67-110C A (NA82-67-110E)	1				-4106
NA80-67-110E	1	(W/O A.LOCK BRAKE)			4106-
NA82-67-110E	1	(A.LOCK BRAKE)			4106-
67-990F		BRACKET,HARNESS			
NA01-67-BJ0	1				
3C01 NA3***-507607					
4106 NA3***-509503					

CAT. AUNA04-03

1995-04

6701 WIRING HARNESSSES(ENGINE & T/MISSION)

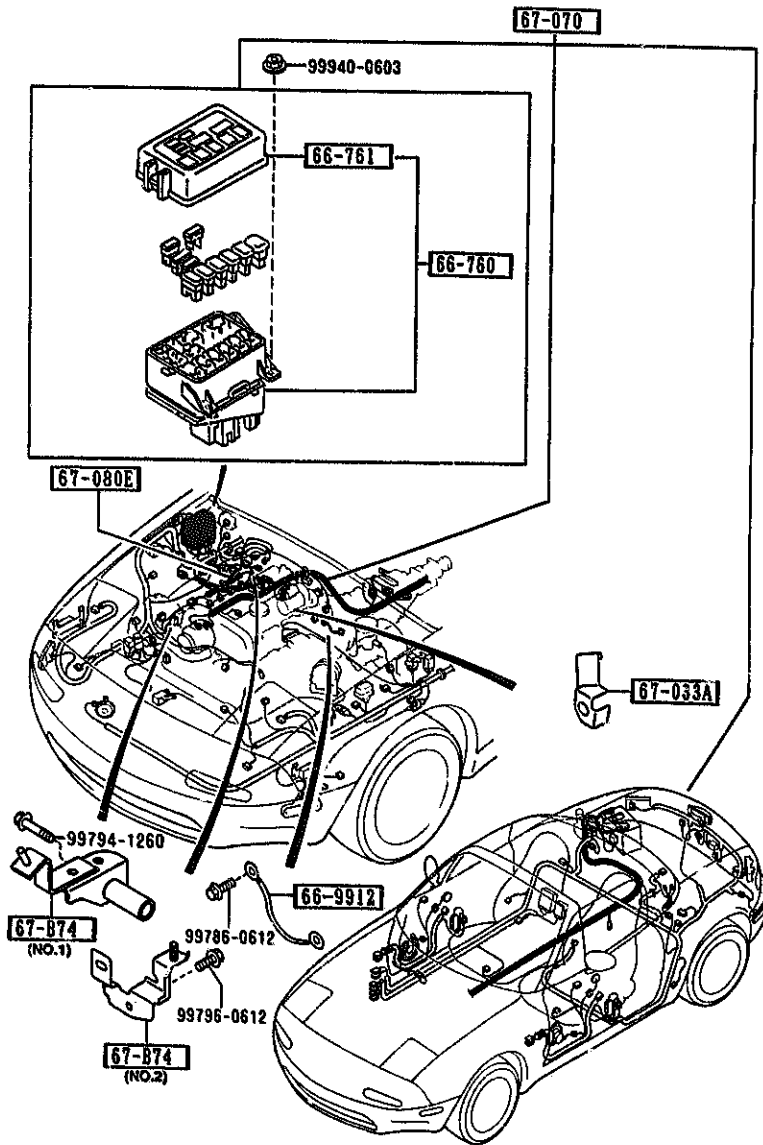

AUNA04

6701 -1 * WIRING HARNESSSES(ENGINE & T/MISSION)

PART NO.	QTY	MODEL/RESTRICTION	MODEL/RESTRICTION	MODEL/RESTRICTION	FROM-TO
66-760		BLOCK,MAIN FUSE			
NAB0-66-760	1				
66-761		COVER,MAIN FUSE BLOC K			
NAB0-66-762	1				
66-9912		WIRE,EARTH			
NA75-67-EW1B	1				
67-B74		BRACKET,HARNESS			
NAB0-67-B80	1	(ILLUST. NO.1)			
NO27-67-B80	1	(ILLUST. NO.2)			
67-033A		BRACKET,WIRING			
NA01-67-B10B	1				
67-070		HARNESS,ENGINE			
NAB0-67-070C	1	((MT)>(A.LOCK BRAKE))			
NAB2-67-070C	1	((AT)>(A.LOCK BRAKE))			
NA75-67-070C	1				-3A25
AN(NA75-67-070D)					
NAB1-67-070C	1				-3A25
AN(NAB1-67-070D)					
NA75-67-070D	1	((MT)>(W/D A.LOCK BR AKE))			3A25-
NAB1-67-070D	1	((AT)>(W/D A.LOCK BR AKE))			3A25-
67-080E		WIRING,INJECTOR			
NA75-67-080B	1				-4601
A(NA75-67-080C)					
NA75-67-080C	1				4601-

3A25 NA3***-505655
4601 NA3***-519089

CAT. AUNA04-03

1995-04

6702 WIRING HARNESSSES(DASHBOARD)

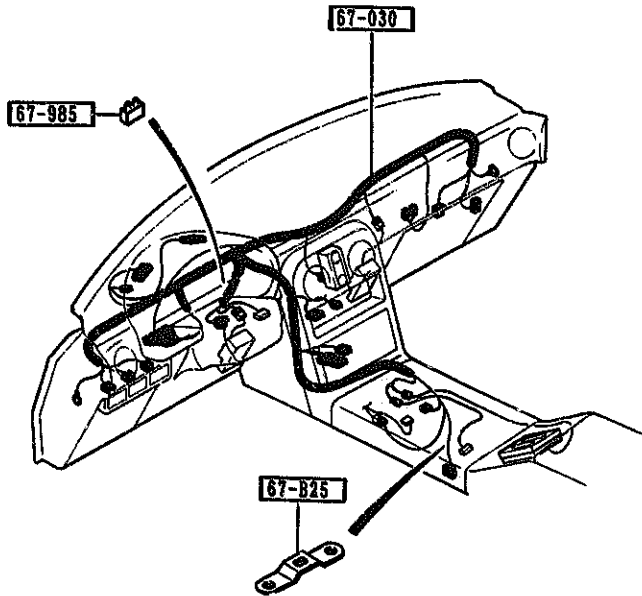

6702 -1 * WIRING HARNESSSES(DASHBOARD)

PART NO.	QTY	MODEL/RESTRICTION	MODEL/RESTRICTION	MODEL/RESTRICTION	FROM-TO
67-B25 NA01-67-B31	1	BRACKET, HARNESS			
67-030 NA75-67-030C ANCNA75-67-030D	1	HARNESS, INSTRUMENT			-4106
NA80-67-030C ANCNA80-67-030D	1				-4106
NA81-67-030C ANCNA81-67-030D	1				-4106
NA82-67-030C ANCNA82-67-030D	1				-4106
NA75-67-030D	1	(W/O SENSORY SOUND) (MT)			4106-
NA80-67-030D	1	(W/SENSORY SOUND) (MT)			4106-
NA81-67-030D	1	(W/O SENSORY SOUND) (AT)			4106-
NA82-67-030D	1	(W/SENSORY SOUND) (AT)			4106-
67-985 NA80-67-SC0	1	CONNECTOR, SHORT (USA)			

4106 NA3***-509503

AUNA04

CAT. AUNA04-03

1995-04

6703 WIRING HARNESSES(DOOR,FLOOR/CEILING)

6703 -1 * WIRING HARNESSES(DOOR,FLOOR/CEILING)

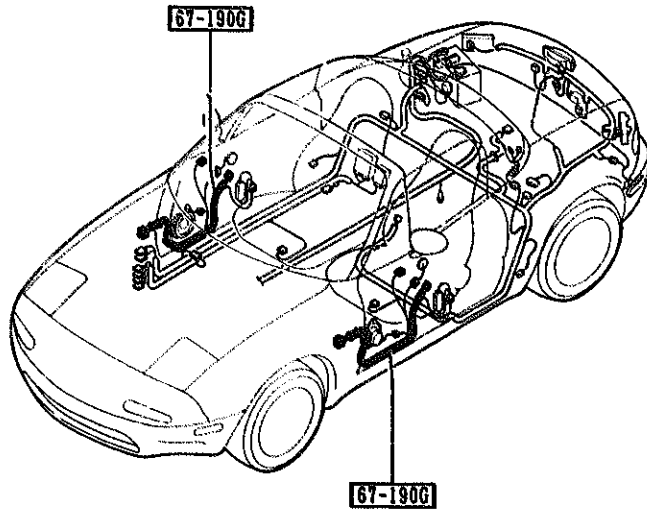

PART NO.	QTY	MODEL/RESTRICTION	MODEL/RESTRICTION	MODEL/RESTRICTION	FROM-TO
67-190G		HARNES, DOOR			
NA01-67-190A	2	BASE, (DR MIRROR MANUAL, W/ O SENSORY SOUND, W/O P. WIND.)			
NA02-67-190A	2	RICO-OPT-PKG, (DR MIRROR MANUAL, W/ O SENSORY SOUND, W/P. WIND.)			
NA52-67-190B	2	(DR MIRROR MANUAL, W/ SENSORY S.)			
NA53-67-190A	2	PKG-A, PKG-B, PKG-C, (DR MIRROR ELECT, W/O SENSORY S.)			
NA54-67-190B A (NA54-67-190C)	2				-3901
NA54-67-190C	2	PKG-B-OPT, PKG-C-OPT (DR MIRROR ELECT, W/S ENSORY S.)			3901-
3901 NA3***-502360					

AUNA04

CAT. AUNA04-03

1995-04

2-K14

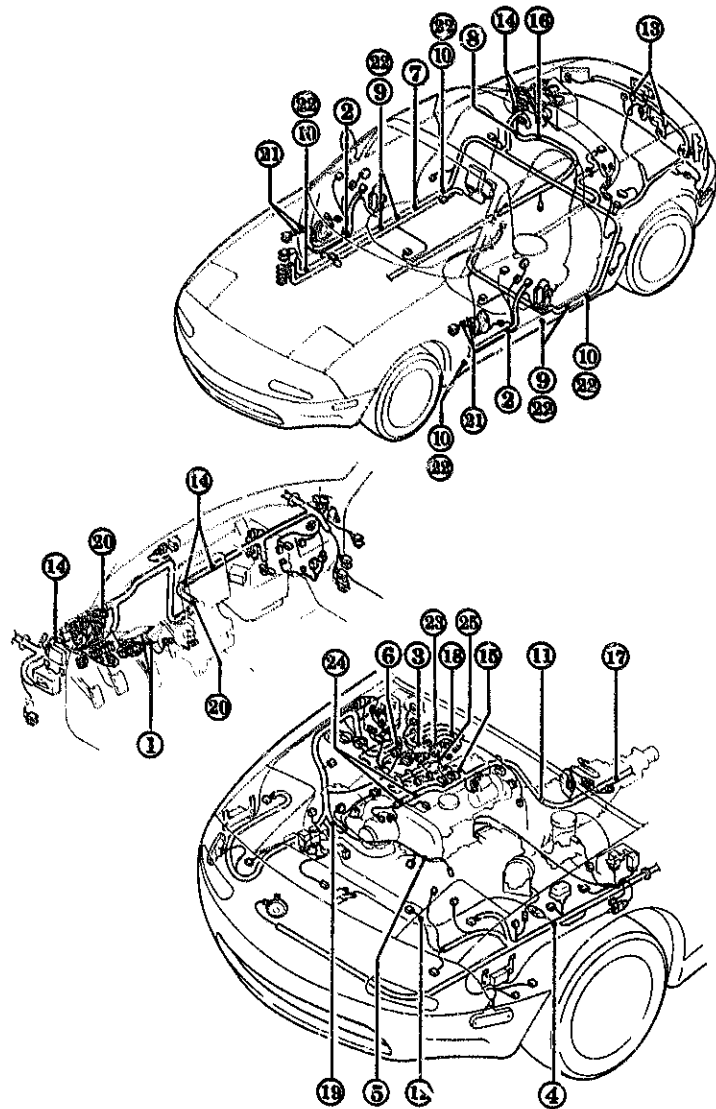

AUNA04

① 14-726 	② 45-961B 	③ 67-CS1 99786-0612	④ 67-CT2 	⑤ 67-011C
⑥ 67-013A 	⑦ 67-013D 	⑧ 67-014F 99786-0620	⑨ 67-022 	⑩ 67-026
⑪ 67-048A 99786-0612	⑫ 67-051E 	⑬ 67-051J 	⑭ 67-052H 	⑮ 67-062A 99786-0612
⑯ 67-072H 99786-0620	⑰ 67-073 90845-0612	⑱ 67-073B 99940-0603	⑲ 67-074 99786-0612	⑳ 67-076
㉑ 67-191 	㉒ 68-865 	㉓ 28-C10 	㉔ 34-C10 	㉕ 66-941A

AUNA04

6794 WIRING HARNESS CLAMPS

(1/2)

6704 -1 WIRING HARNESS CLAMPS

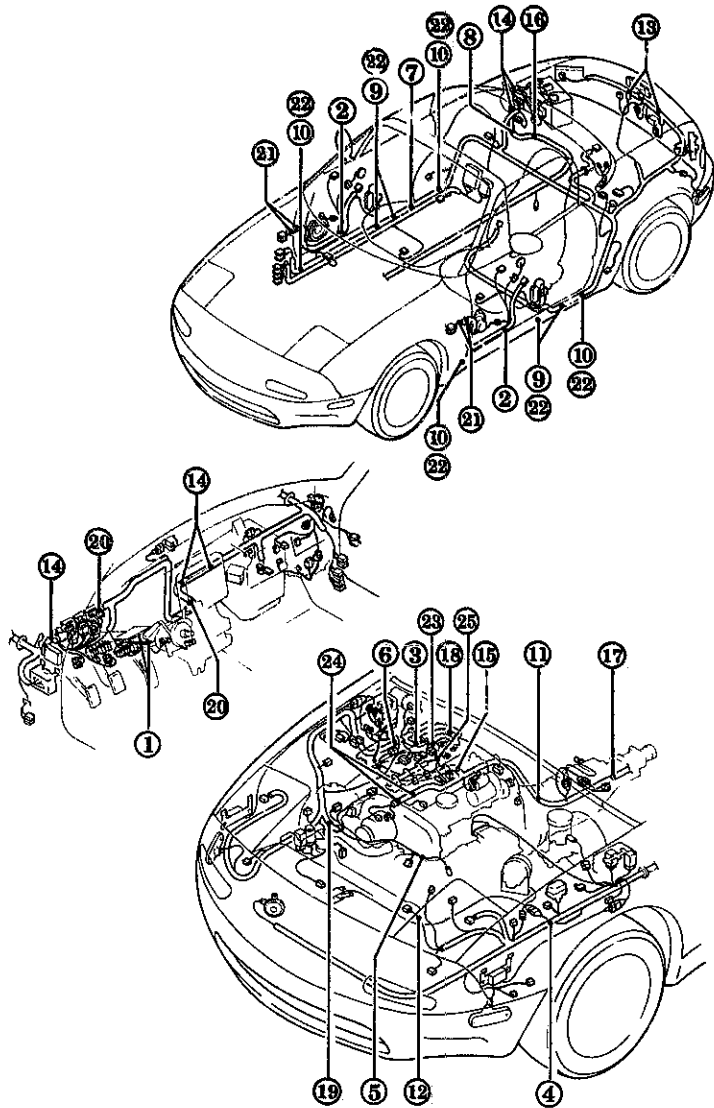

PART NO.	QTY	MODEL/RESTRICTION	MODEL/RESTRICTION	MODEL/RESTRICTION	FROM-TO
14-726		BAND			
N304-14-726	2				
28-C10		BAND, PIPE			
B214-28-C10	1				
34-C10		BAND, PIPE			
B214-34-C10	2				
45-961B		CAP			
H002-45-961	2				
66-941A		CLIP			
FB01-66-945	1				
67-CS1		CLIP, HARNESS			
NA01-67-CS1C	1				
67-CT2		CLIP, HARNESS			
NA01-67-CH5	1				
67-011C		CLIP			
E356-18-141	1	BASE, (W/O POWER STEERING)			
67-013A		CLIP			
UB42-67-013	1	(W/O A. LOCK BRAKE)			
67-013D		PROTECTOR, HARNESS			
NA01-67-P54	1				
NA75-67-P54	1				
67-014F		PROTECTOR, HARNESS			
NA01-67-P71	1				
67-022		CLIP, HARNESS			
NA01-67-CW5A	4				
67-026		CLIP, HARNESS			
NA02-67-CW5A	4				
4509 NA3***-518031					

























-4509
4509-

AUNA04

CAT. AUNA04-03

1995-04

2-M14

① 14-726 	② 45-961B 	③ 67-CS1 99786-0612 	④ 67-CT2 	⑤ 67-011C 
⑥ 67-013A 	⑦ 67-013D 	⑧ 67-014F 99786-0620 	⑨ 67-022 	⑩ 67-026 
⑪ 67-048A 99786-0612 	⑫ 67-051E 	⑬ 67-051J 	⑭ 67-052H 	⑮ 67-062B 99786-0612 
⑯ 67-072H 99786-0620 	⑰ 67-073 90845-0612 	⑱ 67-073B 99940-0603 	⑲ 67-074 99786-0612 	⑳ 67-076 
㉑ 67-191 	㉒ 68-865 	㉓ 28-C10 	㉔ 34-C10 	㉕ 66-941A 

AUNA04

PART NO.	QTY	MODEL/RESTRICTION	MODEL/RESTRICTION	MODEL/RESTRICTION	FROM-TO
↑ 67-048A ↓ NA01-67-CS1	1	CLIP, HARNESS			
↑ 67-051E ↓ UB42-67-051	1	CLIP			
↑ 67-051J ↓ G031-67-053A	2	CLIP			
↑ 67-052H ↓ G030-67-018A	5	CLIP			
↑ 67-062B ↓ NA02-67-CS1A	1	CLIP, HARNESS			
↑ 67-072H ↓ NA01-67-CS6	1	CLIP, ENGINE HARNESS			
↑ 67-073 ↓ UB73-67-073A	1	CLIP			
↑ 67-073B ↓ H261-67-073	1	CLIP			
↑ 67-074 ↓ NA01-67-CS5	1	CLIP, HARNESS			
↑ 67-076 ↓ NA01-67-CH8	2	CLIP, ENGINE HARNESS			
↑ 67-191 ↓ B300-67-HD1	4	GROMMET			
↑ 68-865 ↓ B003-68-865	8	FASTENER			
00	INT-	NA3 NA5 NA4 NA6 BLACK			

CAT. AUNA04-03

1995-04

2-N14

6720

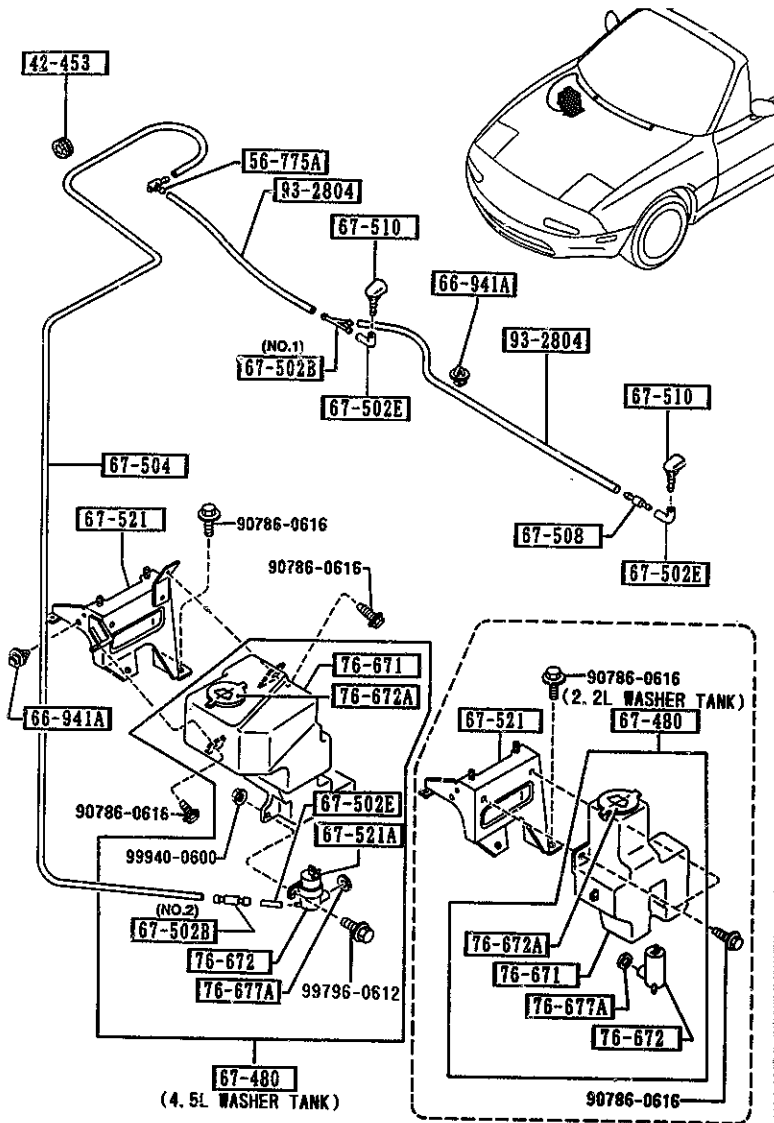
WINDSHIELD WASHER
(W/O ANTI LOCK BRAKE SYSTEM)

AUNA04

6720 -1 WINDSHIELD WASHER
(W/O ANTI LOCK BRAKE SYSTEM)

PART NO.	QTY	MODEL/RESTRICTION	MODEL/RESTRICTION	MODEL/RESTRICTION	FROM-TO
42-453		PROTECTOR,CABLE			
B048-42-453	1				
56-775A		CLIP,WASHER HOSE			
LA01-67-505B	1				
66-941A		CLIP			
G808-66-941	4				
67-480		TANK,WASHER-FRONT			
LA01-67-480A	1	(2.2L WASHER TANK)			
NA04-67-480B	1	(4.5L WASHER TANK)			
67-502B		JOINT,HOSE			
H001-67-502	1	(ILLUST. NO.1)			
4116-67-502	1	(ILLUST. NO.2)			
67-502E		JOINT,ELBOW-W.TANK			
S084-67-502	2	(2.2L WASHER TANK)			
S084-67-502	3	(4.5L WASHER TANK)			
67-504		HOSE,C,WASHER			
NA01-67-501A	1				
67-508		VALVE,CHECK			
FA54-67-508	1				
67-510		NOZZLE,WASHER-F.WIND			
NA01-67-510	2				
67-521		BRACKET,WASHER TANK			
NA01-67-520	1	(2.2L WASHER TANK)			
NA04-67-520	1	(4.5L WASHER TANK)			
67-521A		BRACKET			
S095-67-521	1	(4.5L WASHER TANK)			
76-671		TANK,WASHER			
NA01-67-481	1	(2.2L WASHER TANK)			

CAT. AUNA04-03

1995-04

2-C15

6720 WINDSHIELD WASHER
(W/O ANTI LOCK BRAKE SYSTEM)

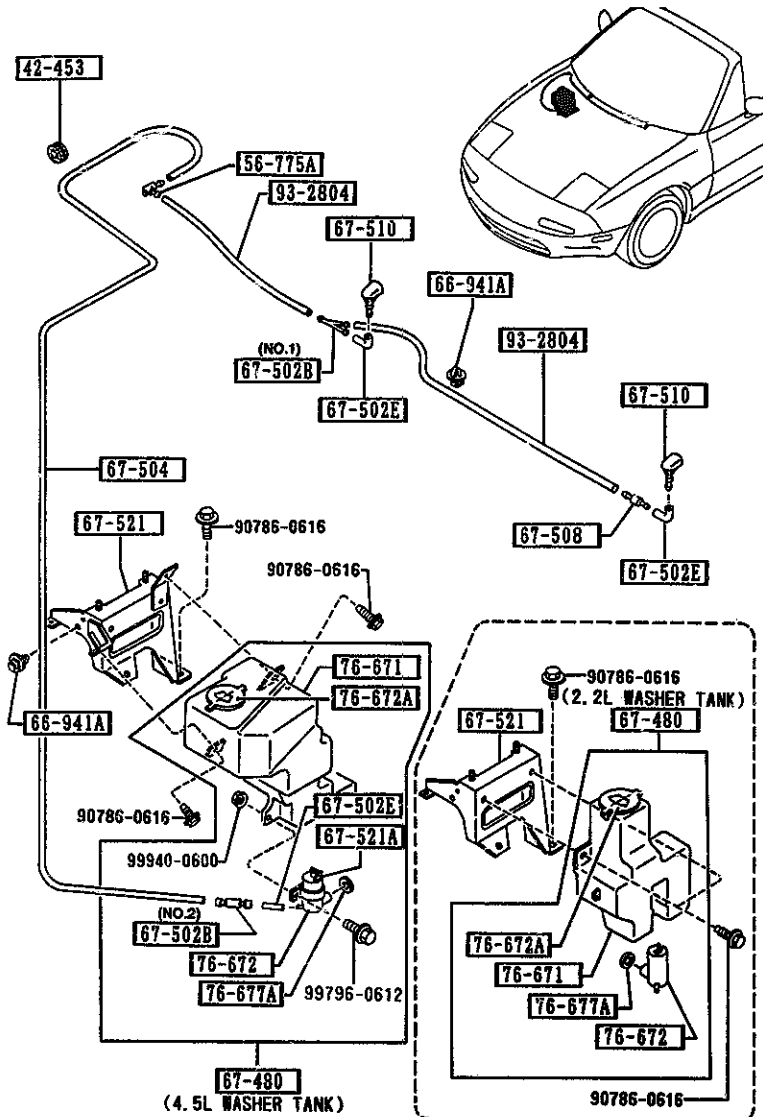

6720 -2 * WINDSHIELD WASHER
(W/O ANTI LOCK BRAKE SYSTEM)

PART NO.	QTY	MODEL/RESTRICTION	MODEL/RESTRICTION	MODEL/RESTRICTION	FROM-TO
CONT'D NA04-67-481	1	(4.5L WASHER TANK)			
↑ 76-672 ↓		PUMP, WASHER			
↑ 76-677A ↓		CAP, TANK			
S084-76-672	1				
↑ 76-672A ↓					
↑ 76-677A ↓		GROMMET, WASHER TANK			
S084-76-677	1				
↑ 93-2804 ↓		PIPE, VINYL			
9932B-04010	1	L=10M			

AUNA04

CAT. AUNA04-03

1995-04

2-D15

6720 A WINDSHIELD WASHER
(ANTI LOCK BRAKE SYSTEM)

6720 A-1 WINDSHIELD WASHER
(ANTI LOCK BRAKE SYSTEM)

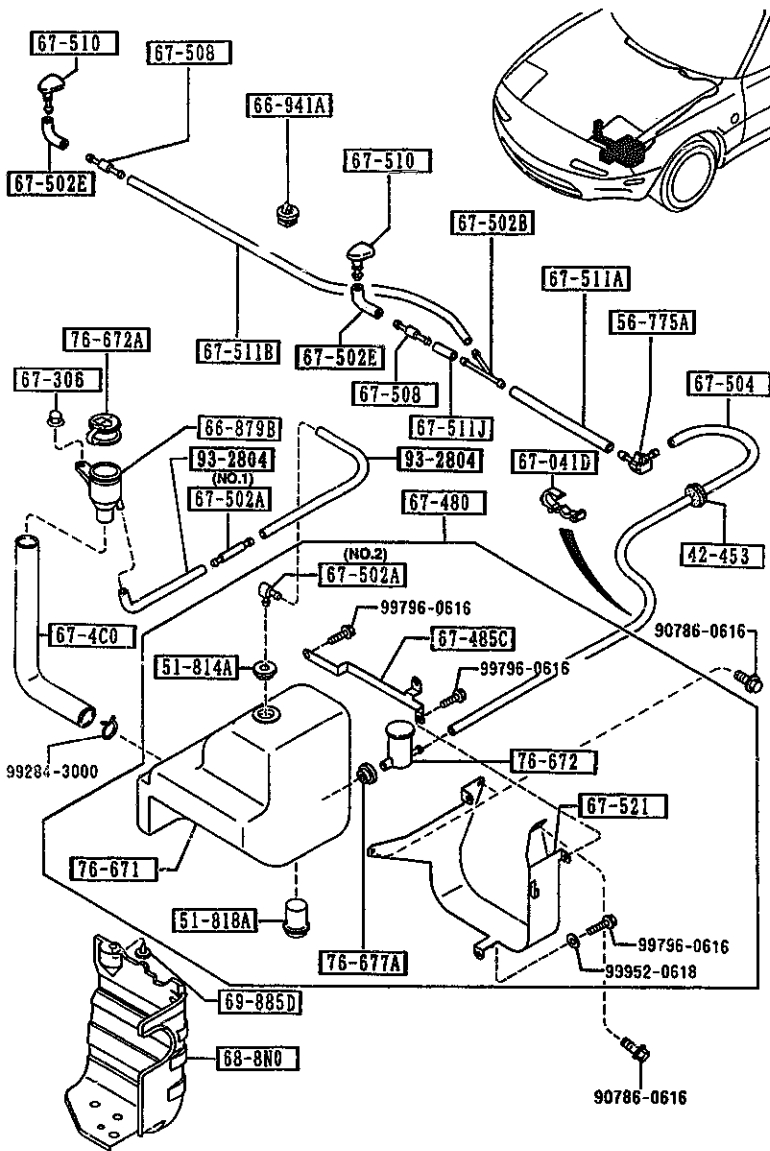

PART NO.	QTY	MODEL/RESTRICTION	MODEL/RESTRICTION	MODEL/RESTRICTION	FROM-TO
42-453		PROTECTOR, CABLE			
B048-42-453	1				
51-814A		GROMMET, WASHER TANK			
B002-51-814	1				
51-818A		SWITCH, LEVEL-WASHER TANK			
NA17-67-488	1				
56-775A		CLIP, WASHER HOSE			
LA01-67-505B	1				
66-879B		JOINT			
NA17-67-4C2	1				
66-941A		CLIP			
GB08-66-941	3				
67-041D		CLIP, HARNESS			
B092-67-041	1				
67-306		NUT, WIPER LINK			
GJ21-67-306	1				
67-4C0		PIPE, FILLER-F. WASHER TANK			
NA17-67-4C1	1				
67-480		TANK, WASHER-FRONT			
NA17-67-4T0A	1				
67-485C		BRKT 'A', WASHER TANK-FRT			
NA18-67-521	1				
67-502A		JOINT, HOSE			
NA17-67-502	1	(ILLUST. NO. 1)			
S013-67-502	1	(ILLUST. NO. 2)			
67-502B		JOINT, HOSE			
H001-67-502	1				

AUNA04

CAT. AUNA04-03

1995-04

6720 A WINDSHIELD WASHER
(ANTI LOCK BRAKE SYSTEM)

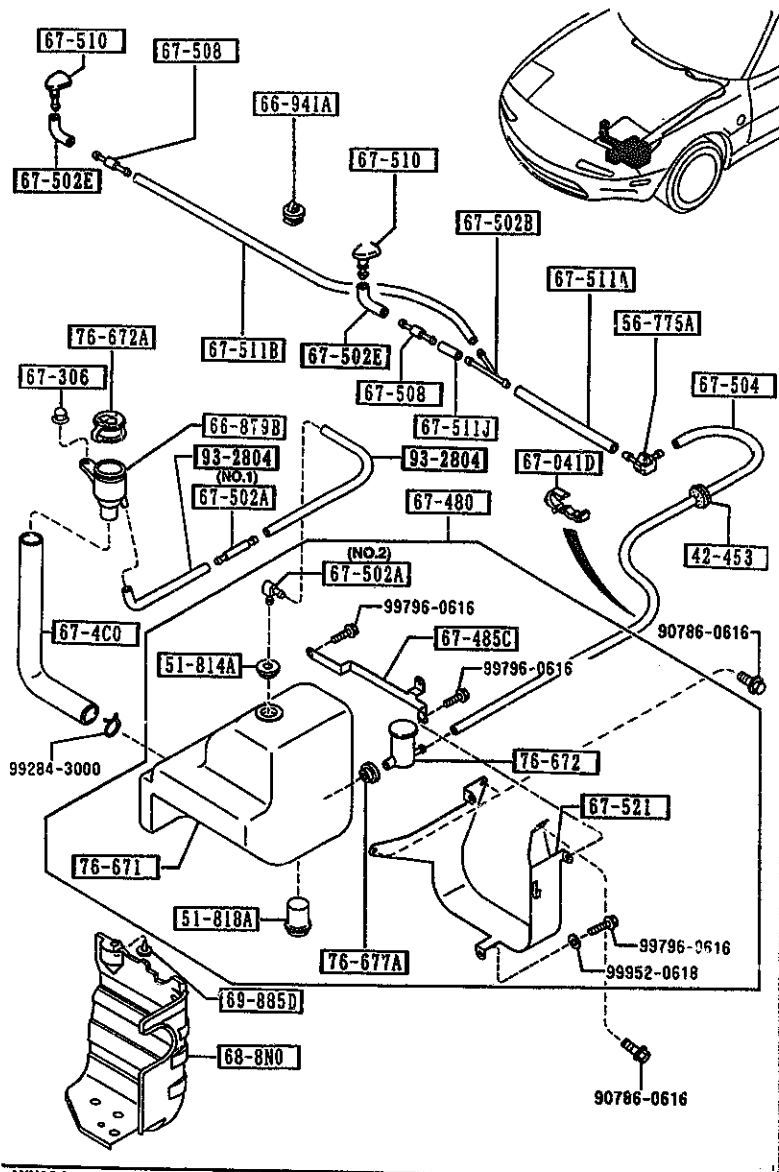

AUNA04

6720 A-2 WINDSHIELD WASHER
(ANTI LOCK BRAKE SYSTEM)

PART NO.	QTY	MODEL/RESTRICTION	MODEL/RESTRICTION	MODEL/RESTRICTION	FROM-TO
67-502E		JOINT, ELBGW-W. TANK			
S084-67-502	2				
67-504		HOSE 'C', WASHER			
NA17-67-501	1				
67-508		VALVE, CHECK			
FA54-67-508	2				
67-510		NOZZLE, WASHER-F. WIND			
NA01-67-510	2				
67-511A		PIPE, SCREEN WASHER			
NA18-67-501	1				
67-511B		PIPE, SCREEN WASHER			
NA19-67-501	1				
67-511J		PIPE, SCREEN WASHER			
NA15-67-501	1				
67-521		BRACKET, WASHER TANK			
NA17-67-521	1				
68-8N0		COVER, WASHER TANK			
NA20-56-181A	1				
69-885D		FASTENER			
NA01-56-145	3				
76-671		TANK, WASHER			
NA17-67-471	1				
76-672		PUMP, WASHER			
LA01-67-482	1				
76-672A		CAP, TANK			
6721 67-483	1				
76-677A		GROMMET, WASHER TANK			
S084-76-677	1				

CAT. AUNA04-03

1995-04

6720 A WINDSHIELD WASHER
(ANTI LOCK BRAKE SYSTEM)

6720 A-3 * WINDSHIELD WASHER
(ANTI LOCK BRAKE SYSTEM)

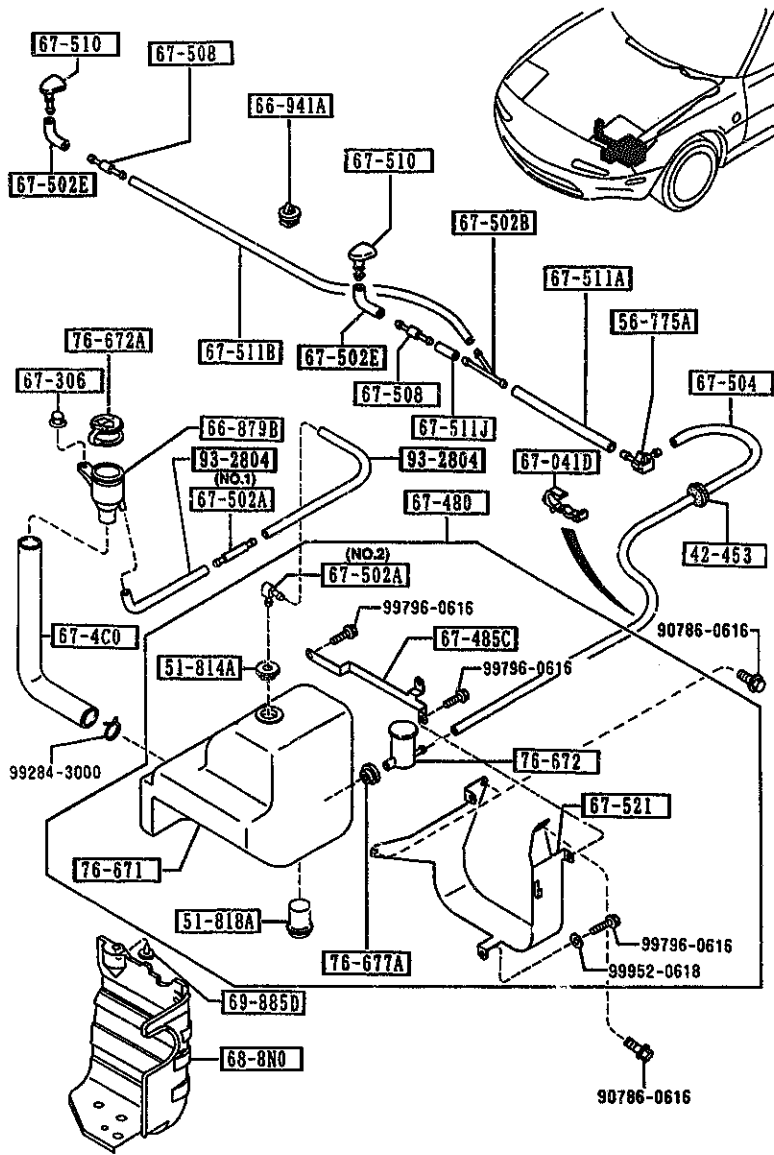

PART NO.	QTY	MODEL/RESTRICTION	MODEL/RESTRICTION	MODEL/RESTRICTION	FROM-TO
93-2804		PIPE, VINYL			
99328-06010	1	L=10M			

AUNA04

CAT. AUNA04-05

1995-04

6730 WINDSHIELD WIPERS

6730 -1 WINDSHIELD WIPERS

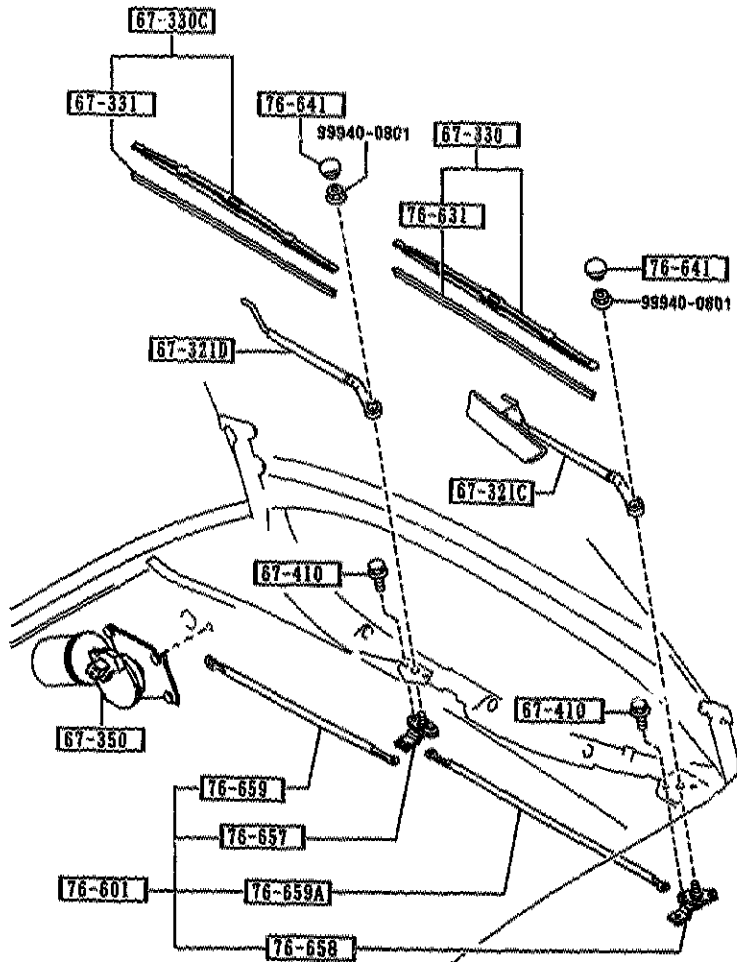

PART NO.	QTY	MODEL/RESTRICTION	MODEL/RESTRICTION	MODEL/RESTRICTION	FROM-TU
67-321C NA01-67-321	1	ARM,WIPER-DRIVER SIDE			
67-321D NA02-67-321	1	ARM,WIPER-CD DRIVER SIDE			
67-330 RMS0-67-330B	1	BLADE,WIPER-FRONT			
67-330C NA02-67-330A	1	BLADE(R),WIPER-FRONT			
67-331 ND02-67-331	1	RUBBER, BLADE-FRONT			
67-350 NA01-67-348B NA04-67-348A	1 1	MOTOR,WIPER (EXC.COLD SPEC) (COLD SPEC)			
67-410 R455-67-369	4	BOLT			
76-601 NA01-67-360A	1	LINK,WIPER			
76-631 D041-67-331	1	RUBBER, BLADE-FRONT			
76-641 LA01-67-395A	2	COVER,WIPER ARM-FRONT			
76-657 NA01-67-363	1	SHAFT,DRIVE NO.1			
76-658 NA01-67-364	1	SHAFT,DRIVE NO.2			
76-659 NA01-67-361	1	ARM NO.1, LINK			

AUNA04

CAT. AUNA04-03

1995-04

6730 WINDSHIELD WIPERS

6730 -2 * WINDSHIELD WIPERS

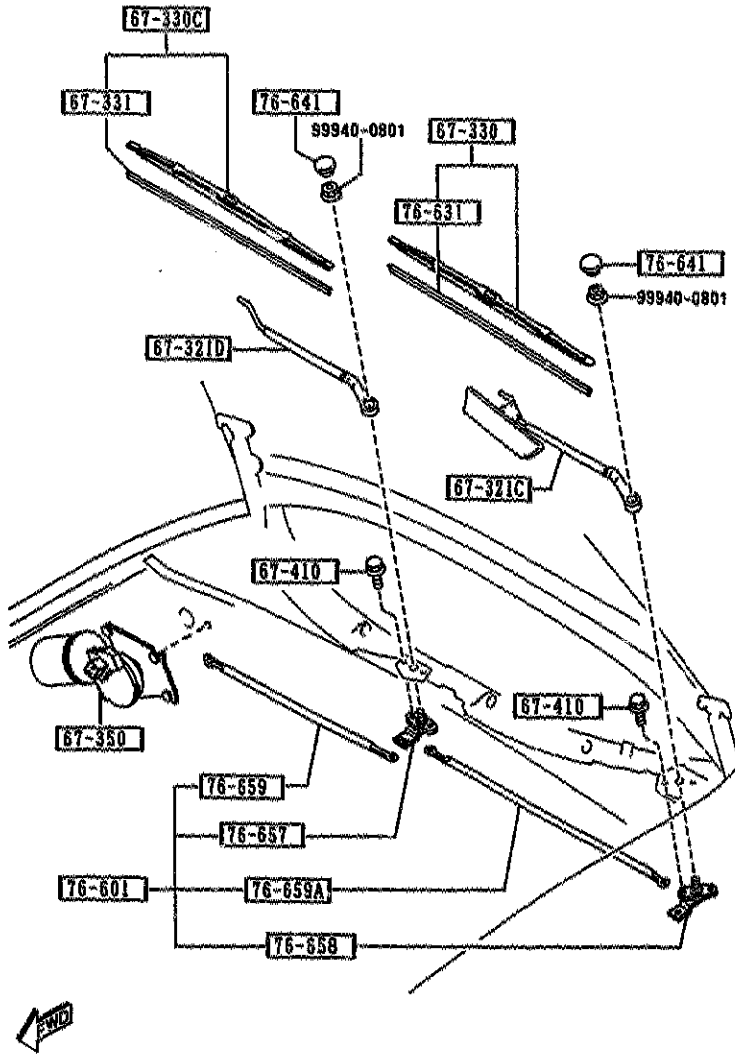

PART NO.	QTY	MODEL/RESTRICTION	MODEL/RESTRICTION	MODEL/RESTRICTION	FROM-TO
76-659A		ARM NO.2, LINK			
NA01-67-362	1				

AUNA04

CAT. AUNA04-03

1995-04

6740 WIPER MOTOR COMPONENTS(FRONT)
 COMPONENTS OF NA01-67-340B
 NA04-67-340A

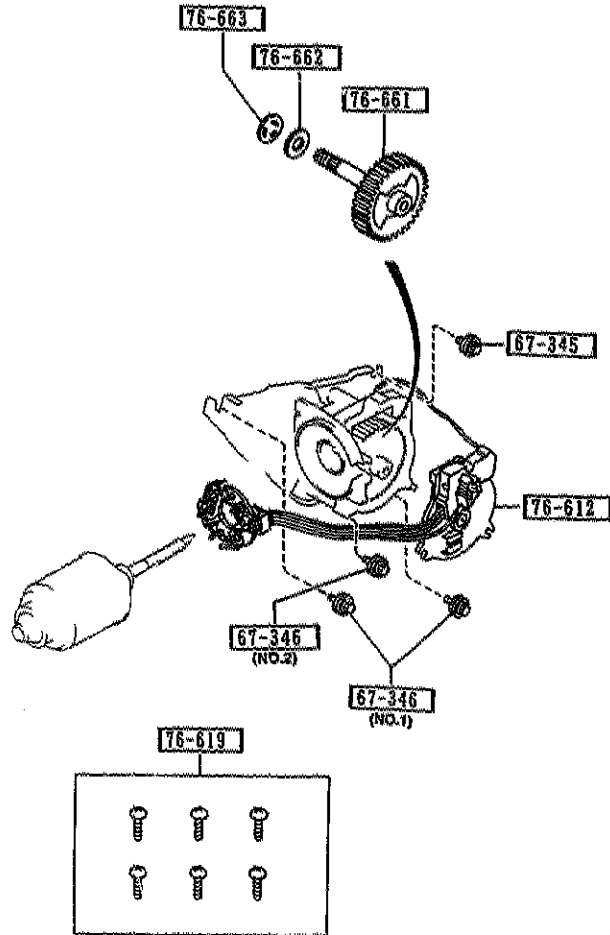

6740 -1 * WIPER MOTOR COMPONENTS(FRONT)

PART NO.	QTY	MODEL/RESTRICTION	MODEL/RESTRICTION	MODEL/RESTRICTION	FROM-TO
67-345 NA01-67-345	1	SCREW,EARTH SET-MOTO R BRK			
67-346 NA01-67-346	2	SCREW,BRACKET-WIPER MOTOR			
NA23-67-346	1	(ILLUST. NO.1)			
NA23-67-346	1	(ILLUST. NO.2)			
76-612 NA23-67-351	1	PLATE,HOLDER-BRUSH			
NA26-67-351	1	(EXC.COLD SPEC)			
76-619 H043-76-619A	1	PARTS SET			
76-661 NA23-67-354	1	GEAR,SHAFT			
76-662 B094-76-662	1	WASHER			
76-663 B094-76-663	1	WASHER,TOOTHED			

AUNA04

CAT. AUNA04-03

1995-04

6820 FRONT HEADER TRIM & PILLAR TRIMS

6820 -1 * FRONT HEADER TRIM & PILLAR TRIMS

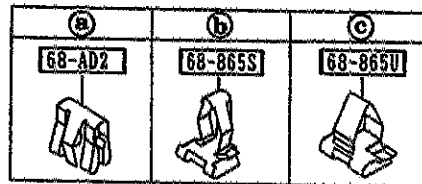
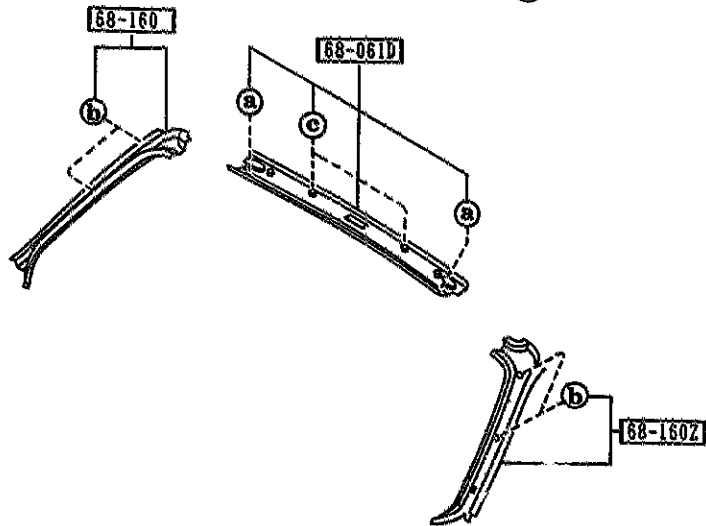
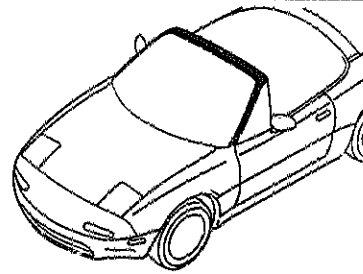

PART NO.	QTY	MODEL/RESTRICTION	MODEL/RESTRICTION	MODEL/RESTRICTION	FROM-TO
68-AD2		CLIP			
8455-68-AD2	2				
68-061D		TRIM, FRONT HEADER			
NA01-68-090A	1				
00	INT-	NA3 NA5 NA4 NA6 BLACK			
68-160		TRIM(R), 'A' PILLAR			
NA01-68-160	1				
00	INT-	NA3 NA5 NA4 NA6 BLACK			
68-160Z		TRIM(L), 'A' PILLAR			
NA01-68-170	1				
00	INT-	NA3 NA5 NA4 NA6 BLACK			
68-865S		CLIP, TRIM			
GJ12-68-865	4				
68-865U		CLIP, TRIM			
GJ21-68-865	2				

AUNAD4

CAT. AUNAD4-03

1995-04

2-K15

6840 TRIMS & SCUFF PLATES

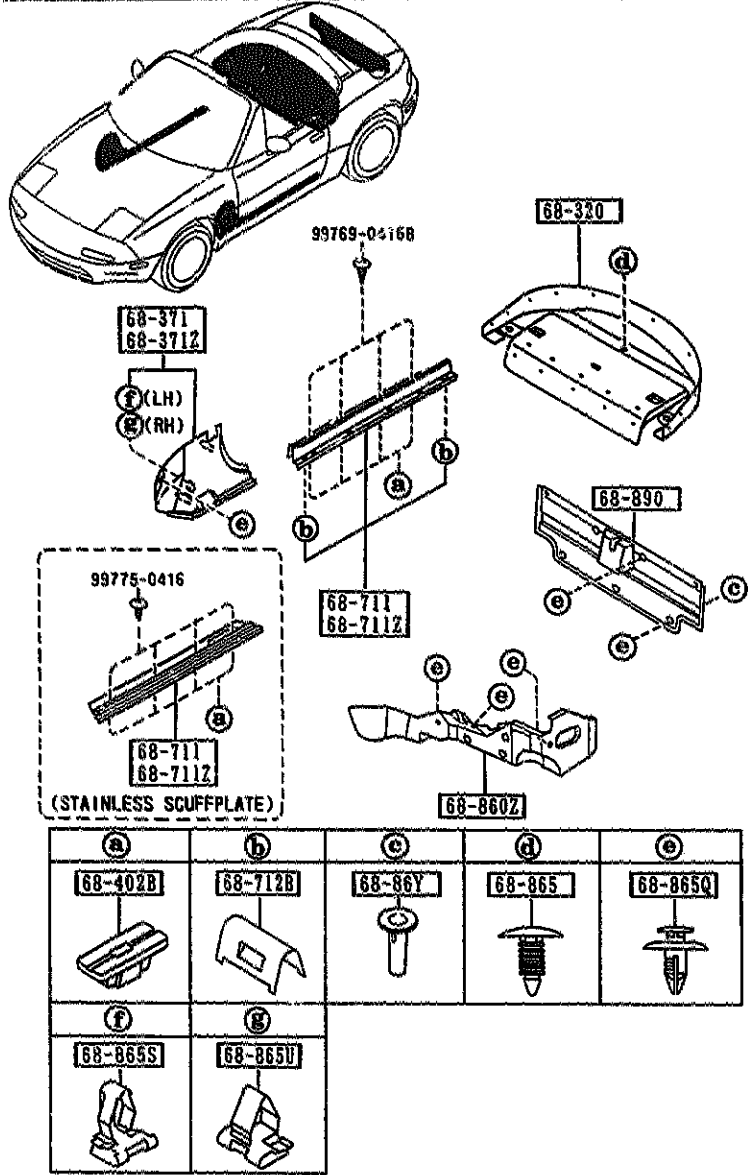

6840 -1 TRIMS & SCUFF PLATES

PART NO.	QTY	MODEL/RESTRICTION	MODEL/RESTRICTION	MODEL/RESTRICTION	FROM-TO
68-320		TRAY,REAR PACKAGE			
NA01-68-3F1B	1				-3C01
00	INT-	NA3 BLACK			
88	INT-	NA4 NA5 TAN			
NA01-68-3F1C	1				3C01-
00	INT-	NA3 BLACK			
88	INT-	NA4 NA5 TAN			
68-371		TRIM(R),FRONT SIDE			
NA75-68-370	1				
00	INT-	NA3 BLACK			
88	INT-	NA5 NA4 TAN			
68-371Z		TRIM(L),FRONT SIDE			
NA01-68-390	1				
00	INT-	NA3 BLACK			
88	INT-	NA5 NA4 TAN			
68-402B		GROHMET,SCREW			
FA54-68-719B	8				
68-711		PLATE(R),FRONT SCUFF			
NA01-68-710	1	BASE, (PLASTIC SCUFFPLATE)			
00	INT-	NA3 NA5 NA4 NA6 BLACK			
NA02-68-710	1	OPT, (STAINLESS SCUFFPLATE)			
68-712		PLATE(L),FRONT SCUFF			
NA01-68-720	1	BASE, (PLASTIC SCUFFPLATE)			
00	INT-	NA3 NA5 NA4 NA6 BLACK			
NA02-68-720	1	OPT, (STAINLESS SCUFFPLATE)			
68-712B		CLIP			
3C01 NA3***-507607					

AUNA04

CAT. AUNA04-03

1995-04

6840 TRIMS & SCUFF PLATES

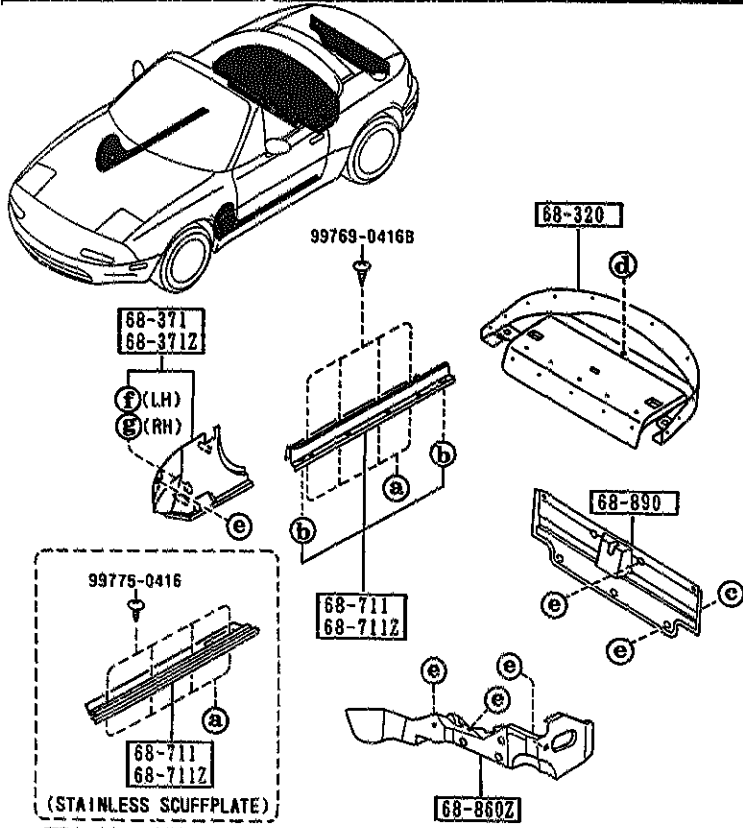

a	b	c	d	e
68-402B	68-712B	68-86Y	68-865	68-865Q
f	g			
68-865S	68-865U			

6840 -2 * TRIMS & SCUFF PLATES

PART NO.	QTY	MODEL/RESTRICTION	MODEL/RESTRICTION	MODEL/RESTRICTION	FROM-TO
CONT'D B235-68-712	4	BASE, (PLASTIC SCUFFPLATE)			
68-86Y		CAP,SEAL-TRUNK END T			
KA01-68-86YA	3	RIM			
68-860Z		TRIM(L),TRUNK SIDE			
N026-68-871	1				
00	INT-	NA3 NA5 NA4 BLACK			
68-865		FASTENER			
G032-68-865A	18				
00	INT-	NA3 BLACK			
67	INT-	NA5 TAN			
68-865Q		FASTENER			
GJ21-68-885B	12				
00	INT-	NA3 NA5 NA4 NA6 BLACK			
88	INT-	NA5 NA4 TAN			
68-865S		CLIP,TRIM			
GJ12-68-865	1				
68-865U		CLIP,TRIM			
GJ21-68-865	1				
68-890		TRIM,TRUNK END			
NA01-68-891	1				
00	INT-	NA3 NA5 NA4 BLACK			

6860 FLOOR MATS & PADS

(a)	(b)	(c)	(d)	(e)	(f)
68-615B	68-615B	68-865	68-865	68-865D	68-866C
(NO.1)	(NO.2)	(NO.1)	(NO.2)		

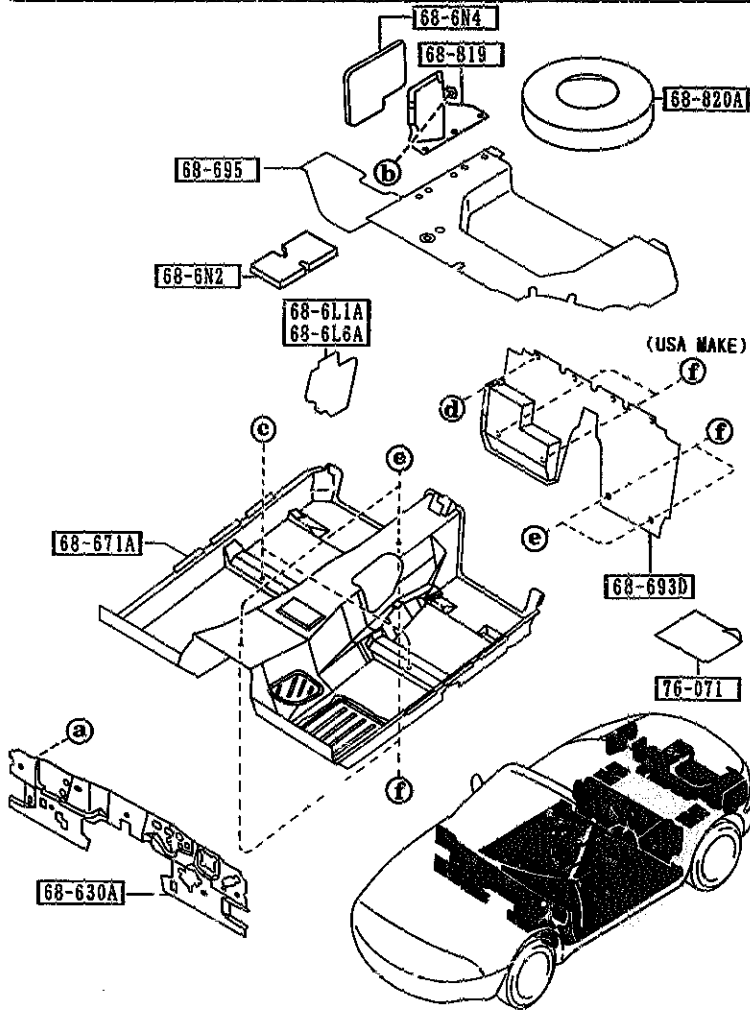

6860 -1 FLOOR MATS & PADS

PART NO.	QTY	MODEL/RESTRICTION	MODEL/RESTRICTION	MODEL/RESTRICTION	FROM-TO
68-6L1A		COVER(R),HOLE			
NA01-68-6L1	1				
68-6L6A		COVER(L),HOLE			
NA01-68-6L6	1				
68-6N2		INSULATOR,RR FLOOR			
NA01-68-6N2	2				
68-6N4		PAD,RR FENDER			
NA01-68-6N4	1				
68-615B		NUT,FLANGE-CAP			
B100-68-615	5	(ILLUST. NO.1)			
NA01-68-615	1	(ILLUST. NO.2)			
68-630A		INSULATOR,DASHBOARD			
NA01-68-631D	1				
68-671A		MAT,FLOOR			
NA75-68-670	1	BASE, (USA MAKE)			
00	INT-	NA3 BLACK			
NA76-68-670	1	MONTEGO-B-SE, (JAPAN MAKE)			-3C01
00	INT-	NA3 BLACK			
88	INT-	NA3 NA4 TAN			
NA76-68-670A	1	MONTEGO-B-SE, (JAPAN MAKE)			3C01-
88	INT-	NA4 NA5 TAN			
68-693D		MAT,REAR END			
NA75-68-693	1	BASE, (USA MAKE)			
00	INT-	NA3 BLACK			
NA76-68-693	1	MONTEGO-B-SE, (JAPAN MAKE)			-3C01
00	INT-	NA3 BLACK			
88	INT-	NA3 NA4 TAN			
NA76-68-693A	1	MONTEGO-B-SE, (JAPAN MAKE)			3C01-
3C01 NA3***-507607					

AUNA04

CAT. AUNA04-03

1995-04

6860 FLOOR MATS & PADS

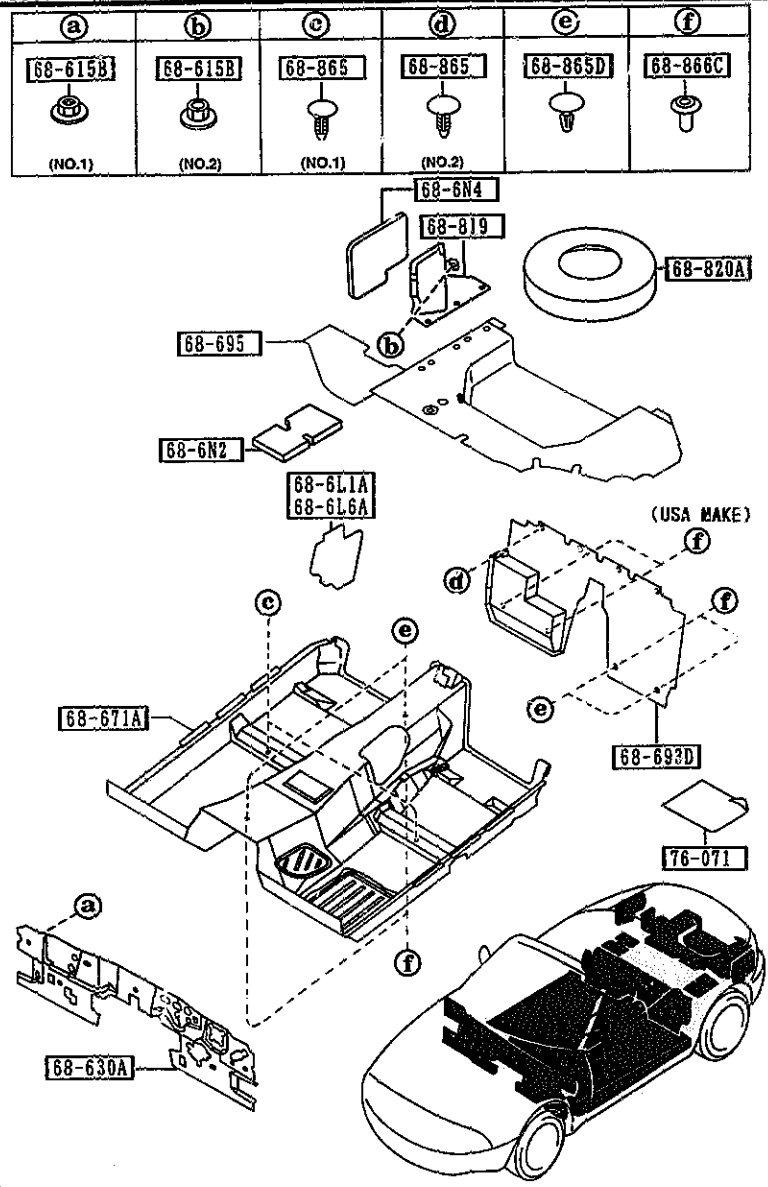

6860 -2 * FLOOR MATS & PADS

PART NO.	QTY	MODEL/RESTRICTION	MODEL/RESTRICTION	MODEL/RESTRICTION	FROM TO
CONT'D					
88	INT-	NA4 NA5 TAN			
68-695		MAT, TRUNK ROOM			
N026-68-811	1				-4201
00	INT-	NA3 NA5 NA4 BLACK			
N026-68-811A	1				4201-
00	INT-	NA3 NA4 NA5 BLACK			
68-819		COVER, BATTERY			
NA01-68-819B	1				
00	INT-	NA3 NA5 NA4 BLACK			
68-820A		COVER, SPARE TIRE			
NA01-68-8P9A	1				
68-865		FASTENER			
B003-68-865	2	(ILLUST. NO.1)			
6032-68-865A	4	(ILLUST. NO.2)			
00	INT-	NA3 BLACK			
67	INT-	NA5 TAN			
68-865D		FASTENER			
S083-68-865A	4				
00	INT-	NA3 BLACK			
88	INT-	NA5 NA4 TAN			
68-866C		FASTENER, SEAL			
B235-68-865A	4	MONTEGO-B-SE, (JAPAN MAKE)			
3235-68-865A	6	BASE, (USA MAKE)			
76-071		SILENCER, FLGDR			
0208-76-071	1	38CMX30CM			
4201 NA3***-511601					

AUNA04

CAT. AUNA04-03

1995-04

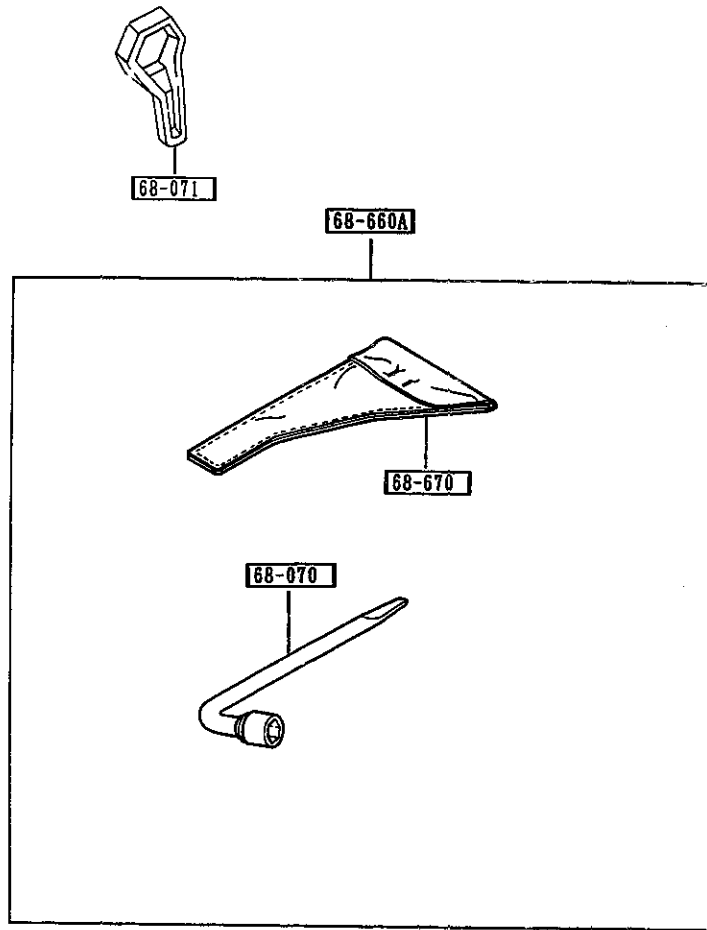

PART NO.	QTY.	MODEL/RESTRICTION	MODEL/RESTRICTION	MODEL/RESTRICTION	FROM TO
68-070		WRENCH, HUB NUT			
NA01-68-070	1				
68-071		WRENCH, WHEEL CAP			
F057-68-071	1				
68-660A		TOOL SET			
NA01-69-650	1				
68-670		BAG, TOOL			
NA01-69-670	1				

6900 VISORS, ASSIST HANDLES & MIRRORS

6900 -1 VISORS, ASSIST HANDLES & MIRRORS

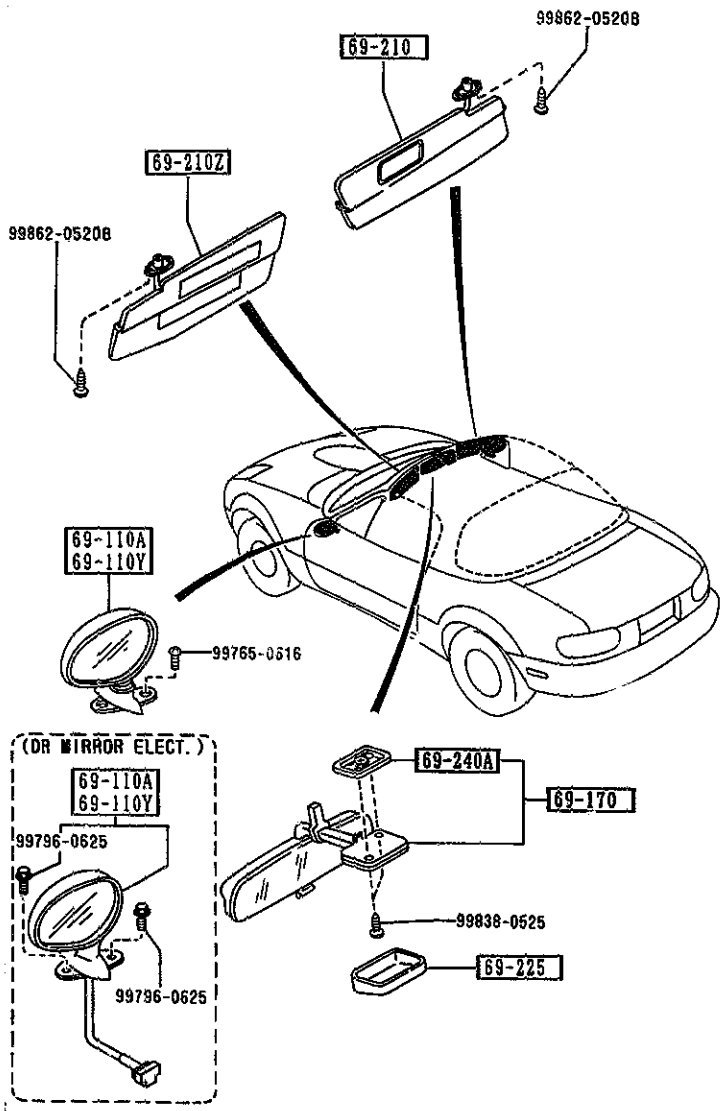

AUNA04

PART NO.	QTY	MODEL/RESTRICTION	MODEL/RESTRICTION	MODEL/RESTRICTION	PKQY-10
69-110A		MIRROR(R), DOOR			
NA05-69-120A	1	BASE, (DR MIRROR MANUAL)			
HU	EXT-	HU NEO GREEN			
PT	EXT-	PT CHAST WHITE			
PZ	EXT-	PZ BRILLIANT BLF			
SU	EXT-	SU CLASSIC RED			
6W	EXT-	6W LAGUNA BLUE M.			
NA52-69-120C	1	PKG-A, PKG-B, PKG-C, (DR MIRROR ELECT.)			
HU	EXT-	HU NEO GREEN			
MB	EXT-	MB MONTEGO BLUE M			
PT	EXT-	PT CHAST WHITE			
PZ	EXT-	PZ BRILLIANT BLACK			
SU	EXT-	SU CLASSIC RED			
6W	EXT-	6W LAGUNA BLUE M.			
69-110Y		MIRROR(L), DOOR			
NA05-69-180A	1	BASE, (DR MIRROR MANUAL)			
HU	EXT-	HU NEO GREEN			
PT	EXT-	PT CHAST WHITE			
PZ	EXT-	PZ BRILLIANT BLACK			
SU	EXT-	SU CLASSIC RED			
6W	EXT-	6W LAGUNA BLUE M.			
NA52-69-180C	1	PKG-A, PKG-B, PKG-C, (DR MIRROR ELECT.)			
HU	EXT-	HU NEO GREEN			
MB	EXT-	MB MONTEGO BLUE M			
PT	EXT-	PT CHAST WHITE			
PZ	EXT-	PZ BRILLIANT BLACK			
SU	EXT-	SU CLASSIC RED			
6W	FXT-	6W LAGUNA BLUE M.			
69-170		MIRROR, INTERIOR			
NA01-69-220	1				
00	INT-	NA3 NA5 NA4 NA6 BLACK			

-4701

4701 NAS***-521312

CAT. AUNA04-03

1995-04

6900 VISORS, ASSIST HANDLES & MIRRORS

6900 -2 * VISORS, ASSIST HANDLES & MIRRORS

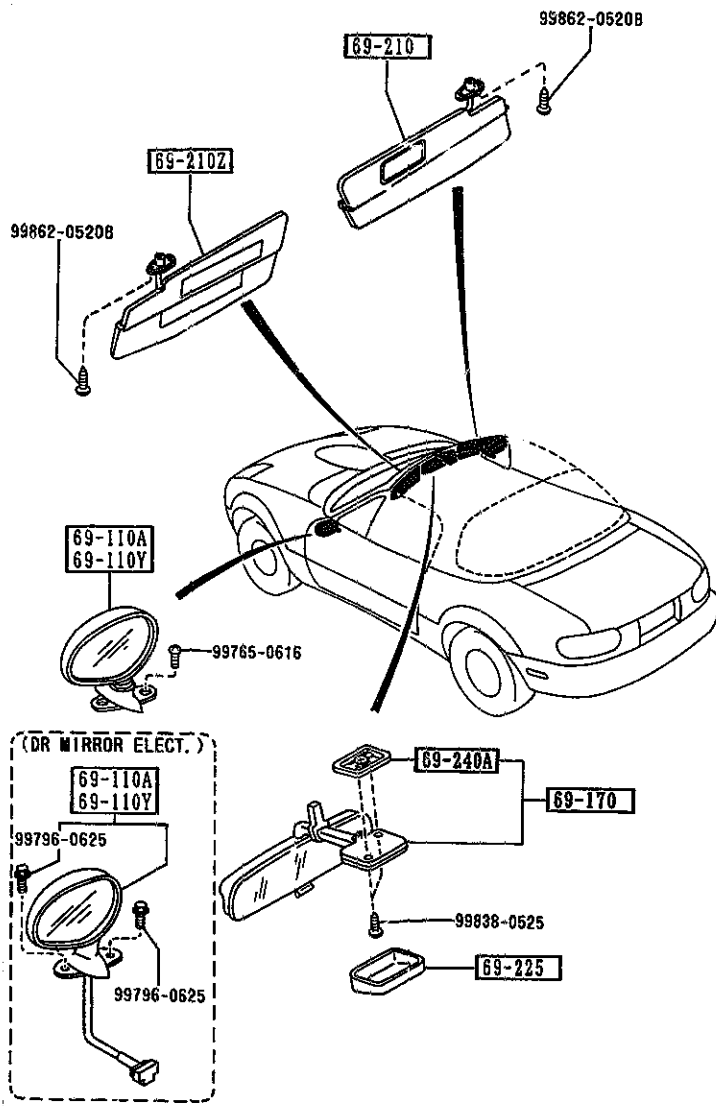

AUNA04

PART NO.	QTY	MODEL/RESTRICTION	MODEL/RESTRICTION	MODEL/RESTRICTION	FRSN-TO
CONT'D					
MNA01-69-220A	1				4701-
+ 69-210 +		SUN VISOR(R)			
NA01-69-270B	1				
02	INT-	NA5 NA3 NA4 BLACK			
+ 69-210Z +		SUN VISOR(L)			
NA/5-69-320	1	(W/AIR BAG-DRIV.&PAS S.SIDE)			
02	INT-	NA3 NA5 NA4 BLACK			
+ 69-225 +		COVER, INTERIOR MIRROR			
GJ21-69-225	1				
00	INT-	NA3 NA5 NA4 NA6 BLACK			
+ 69-240A +		BASE, INTERIOR MIRROR			
NA01-69-240	1				

4701 NA3***-521312

CAT. AUNA04-03

1995-04

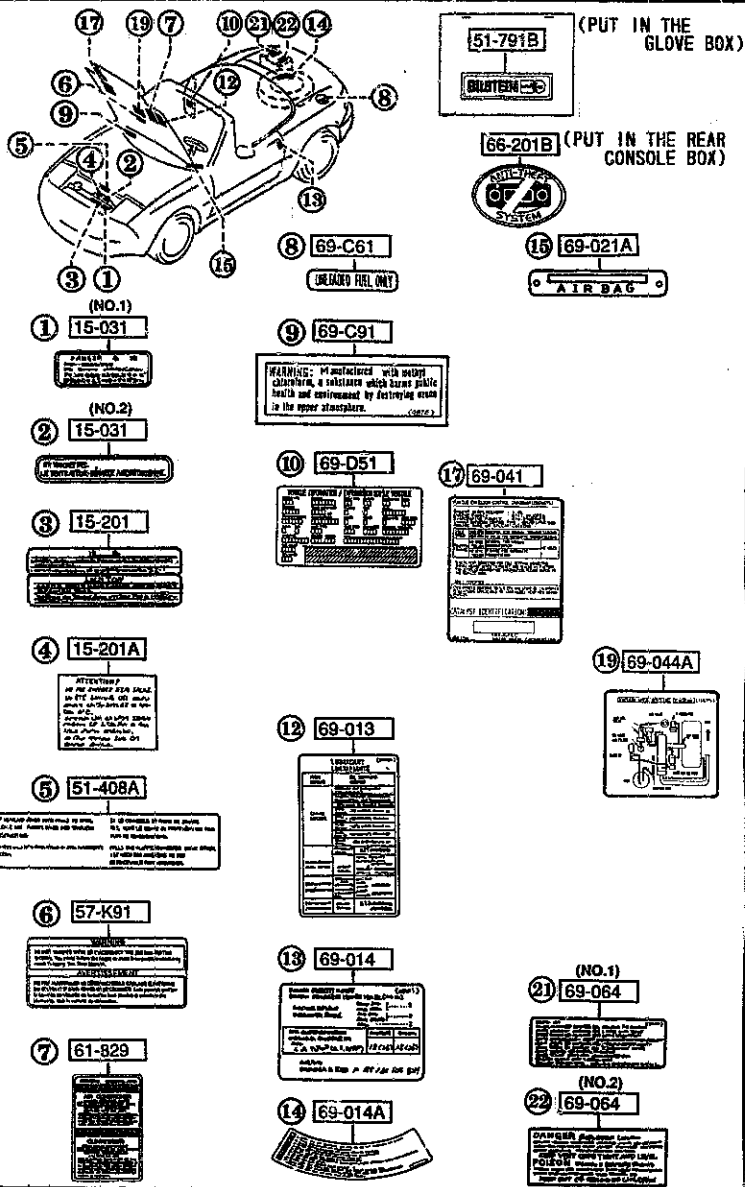

PART NO.	QTY	MODEL/RESTRICTION	MODEL/RESTRICTION	MODEL/RESTRICTION	FROM-TO
15-031		LABEL, CAUTION			
B660-15-031	1	(ILLUST. NO.1)			
E508-15-031	1	(ILLUST. NO.2)			
15-201		PLATE, CAUTION			
0488-15-201	1				
15-201A		LABEL, CAUTION-RADIATOR			
8791-15-201	1				
51-408A		LABEL, CAUTION-RETRACTABLE			
A409-51-502	1				
51-791B		LABEL, BILSTEIN			
N021-51-790	1	(BILSTEIN DAMP.)			
57-K91		LABEL 'A', CAUTION-A/B			
KA78-57-K91	1				
61-829		LABEL, CAUTION			
FD16-61-439B	1	(A)			
66-201B		LABEL, ANTI THEFT-AUDIT			
NA01-66-201	1	(W/O SENSORY SOUND)			
69-C61		LABEL, UNLEADED FUEL			
UB40-69-C61	1				
69-C91		LABEL, CFC			
GB7E-69-C91	1	(W/HFC LABEL)			-3901
69-D51		LABEL, VEHICLE INFORMATION			
B001-69-D51	1	VIN NO. IS REQUIRED			
69-013		LABEL, OIL			
NA01-69-D215	1				-4201
69-014		LABEL, TIRE			
NA01-69-014	1				
3901 NA3***-502360					
4201 NA3***-511601					

AUNA04

CAT. AUNA04-03

1995-04

6930 CAUTION PLATES & LABELS

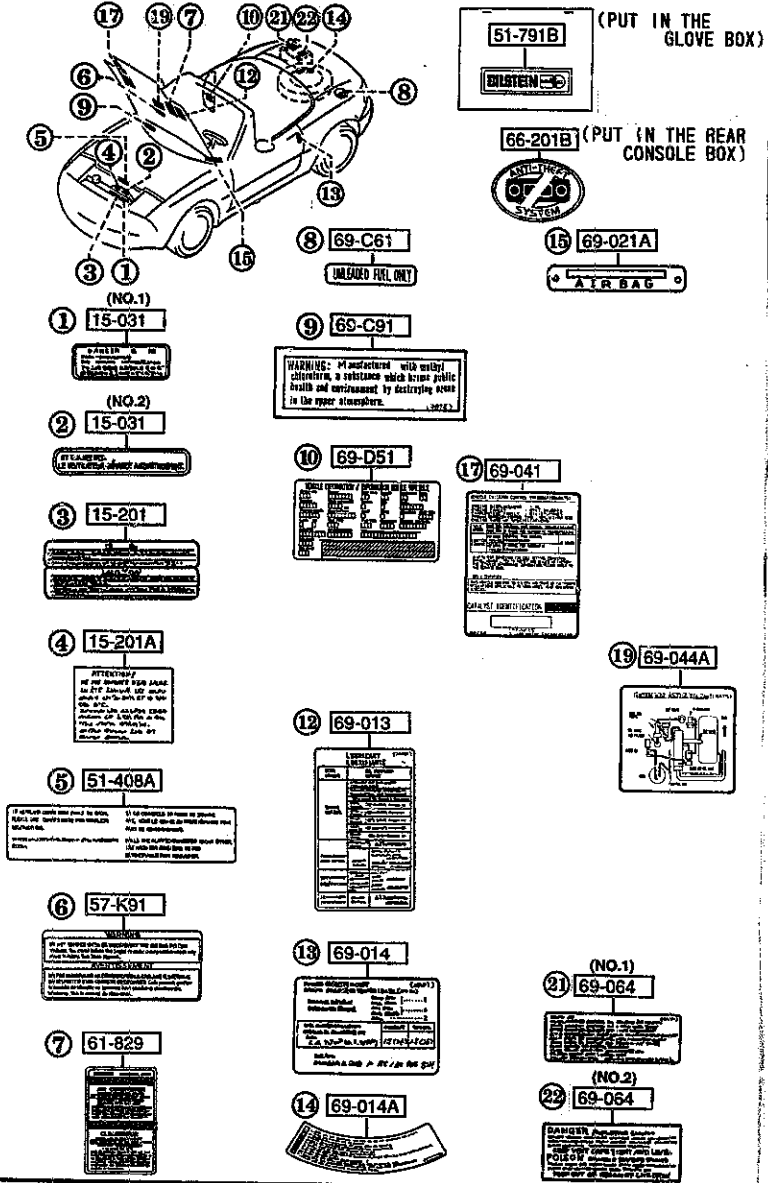

6930 -2 * CAUTION PLATES & LABELS

PART NO.	QTY	MODEL/RESTRICTION	MODEL/RESTRICTION	MODEL/RESTRICTION	FROM TO
69-014A		LABEL, TEMPORARY TIRE			
BF68-69-073		ENGLISH			
BF69-69-073B	1	FRENCH			
69-021A		PLATE, CAUTION			
NA01-69-068A	1				
69-021A		LABEL, EMISSION			
NA75-69-036	1	ENGLISH			
69-044A		LABEL, VAC. DIAPHRAGM			
NA75-69-044	1	(USA)			
69-064		LABEL, BATTERY			
FA03-69-C72A	1	(ILLUST. NO.1) (W/BATTERY LABEL)			
FA01-69-064A	1	(ILLUST. NO.2) (W/BATTERY LABEL)			

AUNA04

CAT. AUNA04-03

1995-04

2-H16

7250 -1 * QUARTER WINDOW & TRIMS

7250 QUARTER WINDOW & TRIMS

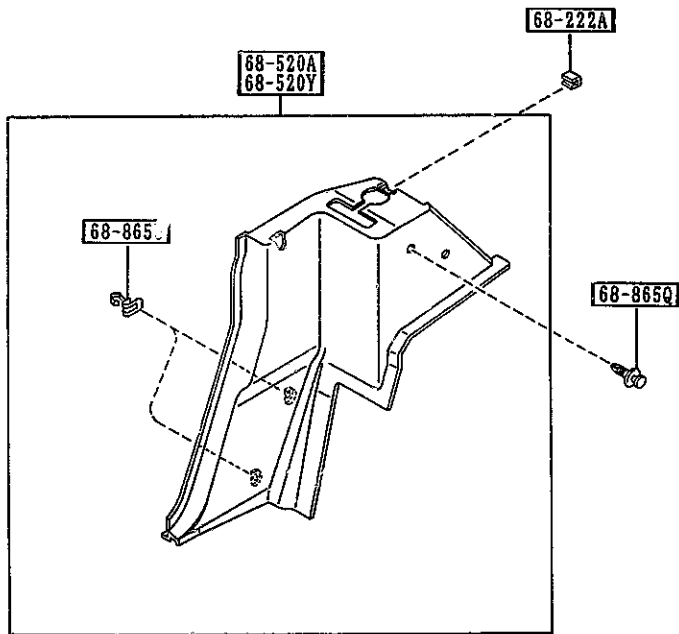

PART NO.	QTY	MODEL/RESTRICTION	MODEL/RESTRICTION	MODEL/RESTRICTION	FROM-TO
68-222A		COVER, HOLE			
NA01-68-222A	2				
00	INT-	NA3 NA6 BLACK			
88	INT-	NA5 NA4 TAN			
68-520A		TRIM(R), QUARTER			
NA75-68-520	1	(W/O DETACHABLE HARD TOP)			
00	INT-	NA3 NA6 BLACK			
88	INT-	NA4 NA5 TAN			
NA76-68-520	1	(W/DETACHABLE HARD TOP)			
00	INT-	NA3 NA6 BLACK			
88	INT-	NA4 NA5 TAN			
68-520Y		TRIM(L), QUARTER			
NA75-68-550	1	(W/O DETACHABLE HARD TOP)			
00	INT-	NA3 NA6 BLACK			
88	INT-	NA4 NA5 TAN			
NA76-68-550	1	(W/DETACHABLE HARD TOP)			
00	INT-	NA3 NA6 BLACK			
88	INT-	NA4 NA5 TAN			
68-865Q		FASTENER			
GJ21-68-885B	2				
00	INT-	NA3 NA4 NA5 NA6 BLACK			
88	INT-	NA5 NA4 TAN			
68-865U		CLIP, TRIM			
GJ21-68-865	4				



AUNA04

CAT. AUNA04-03

1995-04